

IMPORTANT INFORMATION:

- A copy of our “Safe Operating Practices” Manuals are always available free of charge either by downloading it from our Technical Publications website @ www.airwinch.com or by contacting the Factory at (800) 866-5457 for North America and (206) 624-0466 for International. The Safe Operating Practices manual must be read prior to anyone operating a **Ingersoll-Rand** winch or hoist. The manual form numbers are as follows:

“Safe Operating Practices Non-Man Rider™ Winches” Manual, Form No. MHD56250

“Safe Operating Practices for Man Rider™ Winches” Manual, Form No. MHD56251

“Safe Operating Practices for Pneumatic, Hydraulic and Electric Hoists” Manual, Form No. MHD56295

- Available winch options may require additional supplements to the basic winch manual.
- For Man Rider™ winches ensure a copy of the Man Rider™ supplement is made available to the operator prior to winch operation.

Winch Man Rider™ Supplements:

Model:	Publication No.
FA2, FA2.5, FH2, FH2.5	MHD56046
FA5	MHD56042 and MHD56220
FA10	MHD56252
FA2.5A	MHD56236
FA2B and HU40A	MHD56207
FH10MR	MHD56212
Fulcrum Electric	MHD56277
LS500HLP/ LS1000HLP	SAM0004

Model:	Publication No.
LS500RLP	SAM0011
LS1000RLP	SAM0012
LS150RLP	SAM0082
LS150RLP/500/ 1000	SAM0115
LS150RLP and LS150PLP-PH	SAM0120
LS500RLP-E	SAM0122
LS150RLP- DP5M-F	SAM0184
LS150HLP	SAM0222

- We strongly recommend that ALL maintenance on **Ingersoll-Rand** equipment be carried out by personnel certified by **Ingersoll-Rand**, or by **Ingersoll-Rand** Authorized Service Centers.
- Contact the Factory if in doubt about installation, operation, inspection and maintenance instructions.
- Use only Genuine **Ingersoll-Rand** parts when maintaining or repairing a winch, hoist or any component of a winch or hoist.
- ANSI / ASME recommends that a winch or hoist (or any components of a winch or hoist) that has been repaired be tested prior to being placed into service:
 - * **Winches** - ANSI / ASME B30.7 (BASE MOUNTED DRUM HOISTS) Refer to section 7.2.2 - Testing.
 - * **Hoists** - ANSI / ASME B30.16 (OVERHEAD HOISTS - UNDERHUNG) Refer to section 16.2.2 - Testing.

PARTS, OPERATION AND MAINTENANCE MANUAL for MODEL EU AND EUL AIR WINCHES

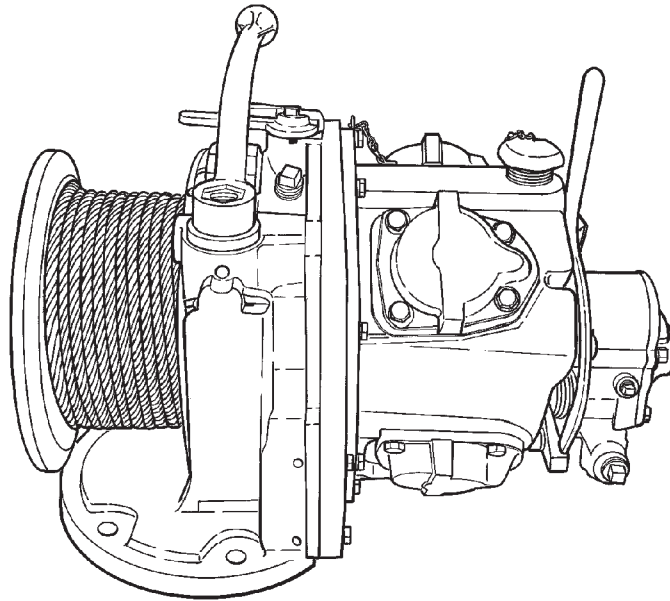

(Dwg. MHP1234)

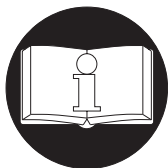

READ THIS MANUAL BEFORE USING THESE PRODUCTS. This manual contains important safety, installation, operation and maintenance information. Make this manual available to all persons responsible for the installation, operation and maintenance of these products.

⚠ WARNING

Do not use this winch for lifting, supporting, or transporting people or lifting or supporting loads over people.

Always operate, inspect and maintain this winch in accordance with American National Standards Institute Safety Code (ASME B30.7) and any other applicable safety codes and regulations.

TABLE OF CONTENTS

Description	Page No.	
Safety Information		
Danger, Caution, Warning and Notice	3	
Safety Summary.....	3	
Safe Operating Instructions	4	
Warning Label.....	4	
Specifications		
Model Code Explanation	5	
Performance Graph	5	
General Specifications	6	
Description.....	6	
Installation		
Mounting.....	7	
Wire Rope	8	
Air Supply.....	9	
Initial Operating Checks	9	
Operation		
Winch Controls	10	
Winch Brakes.....	10	
Free Spool Clutch	10	
Inspection		
Records and Reports	11	
Frequent Inspection.....	11	
Periodic Inspection	12	
Winches Not in Regular Use.....	12	
Inspection and Maintenance Report	13	
Lubrication		14
Troubleshooting		15
Maintenance		
Adjustments	16	
Disassembly	16	
Brake Band Replacement.....	17	
Cleaning, Inspection and Repair	18	
Assembly	18	
Load Test.....	19	
Winch Assembly Parts Lists and Reference Drawings.....	20-31	
Kits, Special Tools and Accessories	32	
Parts Ordering Information		
Return Goods Policy	33	
Warranty.....	35	

SAFETY INFORMATION

This manual provides important information for all personnel involved with the safe installation, operation and proper maintenance of this product. Even if you feel you are familiar with this or similar equipment, you should read this manual before operating the product.

Danger, Warning, Caution and Notice

Throughout this manual there are steps and procedures which, if not followed, may result in a hazard. The following signal words are used to identify the level of potential hazard.

⚠ DANGER Danger is used to indicate the presence of a hazard which *will* cause *severe* injury, death, or substantial property damage if the warning is ignored.

⚠ WARNING Warning is used to indicate the presence of a hazard which *can* cause *severe* injury, death, or substantial property damage if the warning is ignored.

⚠ CAUTION Caution is used to indicate the presence of a hazard which *will* or *can* cause injury or property damage if the warning is ignored.

NOTICE Notice is used to notify people of installation, operation, or maintenance information which is important but not hazard-related.

Safety Summary

⚠ WARNING

- Do not use this winch for lifting, supporting, or transporting people or lifting or supporting loads over people.
- The supporting structures and load-attaching devices used in conjunction with this winch must provide an adequate safety factor to handle the rated load, plus the weight of the winch and attached equipment. This is the customer's responsibility. If in doubt, consult a registered structural engineer.

Ingersoll-Rand winches are manufactured in accordance with the latest ASME B30.7 standards.

The National Safety Council, Accident Prevention Manual for Industrial Operations, Eighth Edition and other recognized safety sources make a common point: Employees who work near suspended loads or assist in hooking on or arranging a load should be instructed to keep out from under the load. From a safety standpoint, one factor is paramount: conduct all lifting or pulling operations in such a manner that if there were an equipment failure, no personnel would be injured. This means keep out from under a raised load and keep out of the intended path of any load.

The Occupational Safety and Health Act of 1970 generally places the burden of compliance with the user, not the manufacturer. Many OSHA requirements are not concerned or connected with the manufactured product but are, rather, associated with the final installation. It is the owner's and user's responsibility to determine the suitability of a product for any particular use. It is recommended that all applicable industry, trade association, federal, state and local regulations be checked. Read all operating instructions and warnings before operation.

Rigging: It is the responsibility of the operator to exercise caution, use common sense and be familiar with proper rigging techniques. Refer to ASME B30.9 for rigging information, American National Standards Institute, 1430 Broadway, New York, NY 10018.

This manual has been produced by **Ingersoll-Rand** to provide dealers, mechanics, operators and company personnel with information required to install, operate, maintain and repair the products described herein.

It is extremely important that mechanics and operators be familiar with the servicing procedures of these products, or like or similar products, and are physically capable of conducting the procedures. These personnel shall have a general working knowledge that includes:

1. Proper and safe use and application of mechanics common hand tools as well as special **Ingersoll-Rand** or recommended tools.
2. Safety procedures, precautions and work habits established by accepted industry standards.

Ingersoll-Rand cannot know of, or provide all the procedures by which product operations or repairs may be conducted and the hazards and/or results of each method. If operation or maintenance procedures not specifically recommended by the manufacturer are conducted, it must be ensured that product safety is not endangered by the actions taken. If unsure of an operation or maintenance procedure or step, personnel should place the product in a safe condition and contact supervisors and/or the factory for technical assistance.

SAFE OPERATING INSTRUCTIONS

The following warnings and operating instructions have been adapted in part from American National (Safety) Standard ASME B30.7 and are intended to avoid unsafe operating practices which might lead to injury or property damage.



Ingersoll-Rand recognizes that most companies who use winches have a safety program in force at their facility. In the event that some conflict exists between a rule set forth in this publication and a similar rule already set by an individual company, the more stringent of the two should take precedence.

Safe Operating Instructions are provided to make an operator aware of dangerous practices to avoid and are not necessarily limited to the following list. Refer to specific sections in the manual for additional safety information.

1. Only allow personnel trained in safety and operation of this product to operate and maintain this winch.
2. Only operate a winch if you are physically fit to do so.
3. When a “**DO NOT OPERATE**” sign is placed on winch, or controls, do not operate winch until sign has been removed by designated personnel.
4. Before each shift, check winch for wear and damage. Never use a winch that inspection indicates is worn or damaged.
5. Never lift a load greater than the rated capacity of the winch. Refer to labels attached to winch and to “SPECIFICATIONS” section.
6. Keep hands, clothing, etc., clear of moving parts.
7. Never place your hand in the throat area of a hook or near wire rope spooling onto or off of the winch drum.
8. Always rig loads properly and carefully.
9. Be certain the load is properly seated in the saddle of the hook. Do not support load on tip of hook.
10. Do not “side pull” or “yard”.
11. Always ensure that you and all other people are clear of the path of the load. Do not lift a load over people.
12. Never use the winch for lifting or lowering people, and never allow anyone to stand on a suspended load.
13. Ease slack out of the wire rope when starting a lift or pull. Do not jerk the load.
14. Do not swing a suspended load.
15. Do not leave a suspended load unattended.
16. Never operate a winch with twisted, kinked or damaged wire rope.
17. Pay attention to the load at all times when operating the winch.
18. Never use the winch wire rope as a sling.
19. After use, or when in a non-operational mode, the winch should be secured against unauthorized and unwarranted use.
20. The operator should maintain an unobstructed view of the load at all times.
21. Properly secure the winch and shut off air supply before leaving winch unattended.
22. Do not do anything you believe may be unsafe.
23. Never splice a sling chain by inserting a bolt between links.
24. Do not force a chain or hook into place by hammering. Do not insert the point of the hook into a chain link.
25. Do not expose the sling chain to freezing temperatures, and do not apply sudden loads to a cold chain.

WARNING TAG





Each winch is shipped from the factory with the warning tag shown. If the tag is not attached to your winch, order a new tag and install it. Refer to the parts list for part number. Tag is shown smaller than actual size.

Read the latest edition of ASME B30.7. Comply with other federal, state and local rules.



WARNING



Failure to follow these warnings may result in death, severe injury or property damage.

BEFORE OPERATING WINCH:

- Do not operate before reading manual(s) supplied with this winch.
- Inspect winch, wire rope and rigging prior to every shift.
- Ensure all winch components and attachments are functioning and properly adjusted.

- Ensure winch anchors and supporting structure are secure and in good condition.
- Ensure winch supply cables and hoses are in good condition and connections are tight.
- Do not operate if malfunctioning or damage is found.
- Use only approved rigging methods.
- Do not make unauthorized modifications.
- Use guards to avoid possible hazards.
- Ensure an accessible shut off valve has been installed in the air supply line and make others aware of its location.
- Use caution when operating in extremely cold temperatures.

READ ADDITIONAL WARNINGS ON OTHER SIDE.

DO NOT REMOVE THIS LABEL.



WARNING

(CONTINUED FROM OTHER SIDE)

WHEN OPERATING WINCH:

- Do not lift people or loads over people.
- Keep hands, clothing, jewelry, etc. away from wire rope, drum and other moving parts.
- Stop winch before touching wire rope.

- Ensure wire rope spools evenly across drum width and each wrap is tight to drum and previous wrap.
- Ensure tension is applied to wire rope when spooling.
- Be aware of load position at all times to avoid moving load into hazardous situations.
- Do not lift or pull load into support structure or winch.
- Do not run wire rope over sharp edges, use approved diameter sheaves.
- Ensure load does not exceed winch, wire rope & rigging ratings.
- Keep everyone clear of load path.
- Keep a minimum of three wraps of wire rope on drum at all times.
- Immediately stop operation if load does not respond to winch control.
- Wear hearing and eye protection.
- Ensure brakes hold prior to making complete lift by lifting load a short distance and releasing control.
- Use only in a well ventilated area.
- Keep clear of motor exhaust.
- Do not allow wire rope storage to exceed drum flange diameter.
- Always shut off air or power supply before servicing or leaving winch unattended.
- Do not remove or obscure this or any other warning label.

READ ADDITIONAL WARNINGS ON OTHER SIDE.

SPECIFICATIONS

Model Code Explanation

Example: EUAB/PT - PZ

Model:

- EU = Standard Winch
- EUL = Long Drum

Automatic Brake:

- AB = Automatic Brake

Remote Control:

- PT = Pendant Throttle
- RC = Remote Control (Full Flow)
- XX Specify control hose length in feet

Options:

- E = Construction Cage
- G = Drum Guard
- P = Marine 812 Finish
- Q = Special Paint, please specify
- R = Natural Gas Operation
- T = Tensioning Manifold
- Z = Sandblast and Carbozinc Primer

Compliance:

- E = Compliance with the European Machinery Directive †

† Not covered in this manual

Performance Graph

EU and EUL Models

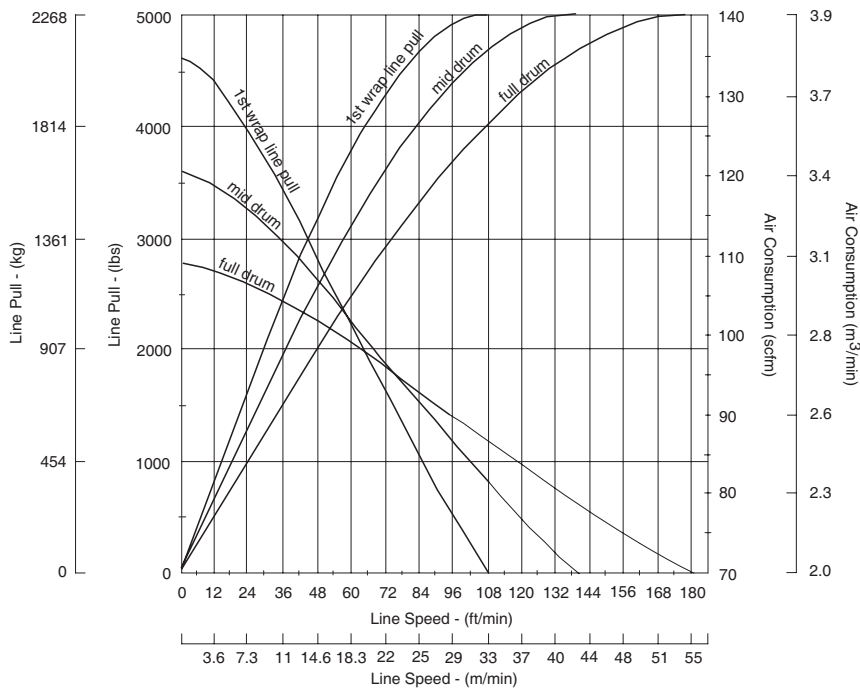

(Dwg. MHP2410)

General Specifications

Air System	Rated Operating Pressure	90 psig (6.3 bar)					
	Consumption Volume (at rated Pressure)	65 scfm			1.8 cu.m/min		
Rated Performance (at rated pressure/volume)	Mid Drum Line Pull	2000 lbs			907 kgs		
	Mid Drum Line Speed	55 fpm			17 m/min		
	Max Stall Pull - 1st Layer	4500 lbs			2041 kgs		
Net Weight		310 lbs			141 kgs		
Air Motor Pipe Inlet Size		3/4 inch NPT					
Air System Hose Size		1 inch			25 mm		
Rope Anchor Hole Diameter		9/16 inch			14 mm		
Drum Barrel Diameter		6 inches			152.4 mm		
Drum Flange Diameter		12.25 inches			311.2 mm		
Motor HP		4.4					
Drum Wire Rope Storage Capacity* (feet/metres)	Drum Length (inches)	Wire Rope Diameter					
		5/16 in.**	8 mm**	3/8 in.	10 mm	7/16 in.	11 mm
	4-13/16	357 ft	109 m	226 ft	69 m	133 ft	40 m
Rope Size (in.)	***Breaking strength lbs	Wt/ft (lbs)	****Recommended safe working load (lbs)				
			Pulling 3.5:1		Lift/Lower 5.0:1		
			lbs	kg	lbs	kg	
5/16 (0.31)	9160	0.18	2617	1187	1832	831	
7/16 (0.44)	17780	0.35	4500	2045	3556	1613	

* Recommended drum working storage capacity is 80% of values shown.

** Recommended wire rope size.

*** Based on improved plow steel wire rope with independent wire rope core.

**** ASME B30.7 requires a minimum 3.5:1 design factor with 15:1 wire rope pitch diameter to drum diameter for most applications (e.g. pulling/hauling and anchor handling). For lifting and lowering, a 5:1 design factor with an 18:1 wire rope pitch diameter to drum diameter is required.

Description

The **EU** and **EUL** winches are powered by a radial piston air motor. The output from the motor is transferred to the drum by the motor shaft. The motor shaft rotates a series of connected spur gears which form a reduction assembly. Output from the reduction assembly drives the wire rope drum. Spur gears are not inherently self-locking as other types of gears are, therefore the brake must be applied whenever there is a load supported by the load line.

INSTALLATION

Prior to installing winch, carefully inspect it for possible shipping damage.

Winches are supplied fully lubricated from the factory. Before operation check oil levels and adjust as necessary. Use the proper type of oil as recommended in the "LUBRICATION" section.

CAUTION

• Owners and users are advised to examine specific, local or other regulations, including American National Standards Institute and/or OSHA Regulations which may apply to a particular type of use of this product before installing or putting winch to use.

Mounting

Mount the winch with the longitudinal center line horizontal and the vent cap (40) at top vertical center. The winch will not function properly if the longitudinal center line is tilted more than 10° or if the winch is rotated so that the vent cap is more than 20° off top vertical center.

For mounting on a vertical surface or for inverted mounting, the motor case (47) can be rotated on the motor case cover (81) to any one of four different positions. This feature allows the motor assembly to be positioned with the vent cap (40) on top. To change the position of the motor assembly, drain the oil from the motor case, unscrew the eight motor case capscrews (39 and 48) and rotate the motor assembly to suit the mounting. Refer to Dwg. MHP1238 on page 7.

EU Model - Bolt Hole Dimensions

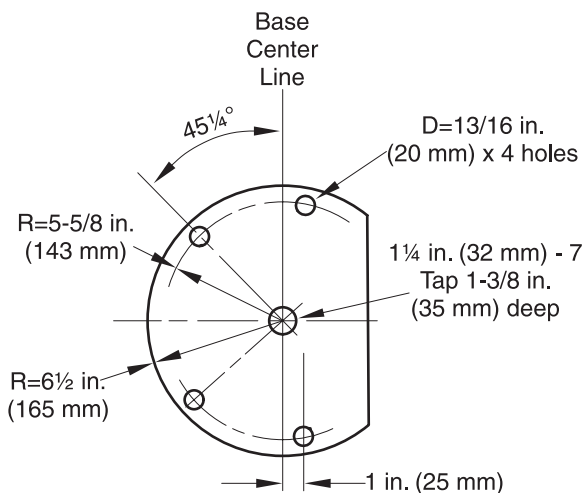

(Dwg. MHP1238)

EUL Model - Bolt Hole Dimensions

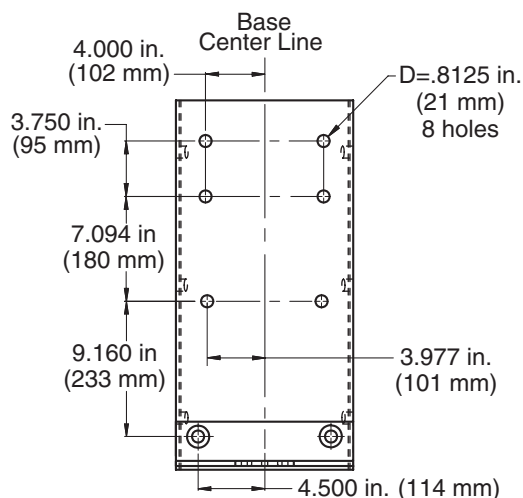

(Dwg. MHP2411)

1. Do not weld to any part of the winch.
2. Winch mounting surface must be flat and of sufficient strength to handle the rated load plus the weight of the winch and attached equipment. An inadequate foundation may cause distortion or twisting of the winch resulting in winch damage.
3. Make sure the mounting surface is flat to within 1/16 inch (2.0 mm). Shim if necessary.
4. Mounting bolts must be 3/4 inch (19 mm) Grade 8 or better. Use self-locking nuts or nuts with lockwashers.
5. Tighten mounting bolts evenly and torque to 375-425 ft lbs (505-575 Nm) for dry thread fasteners. If the fasteners are plated, lubricated or a thread locking compound is used, torque to 282 ft lbs (383 Nm).
6. When a lead sheave is used, it must be aligned with the center of the drum. The diameter of the lead sheave must be at least 18 times the diameter of the wire rope.
7. Maintain a fleet angle between the sheave and winch of no more than 1-1/2°. Refer to Dwg. MHP0498 on page 7. The lead sheave must be on a center line with the drum and be at least 7.2 feet (2.2 metres) from the drum. Refer to Dwg. MHP0498, Note 3.

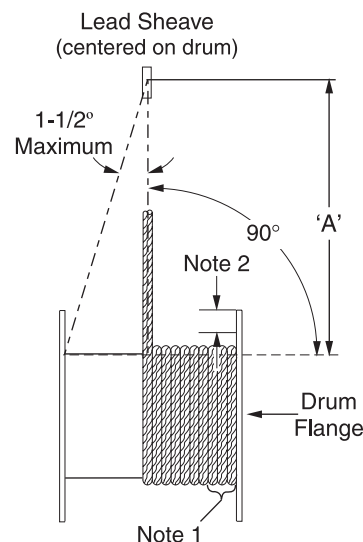

(Dwg. MHP0498)

Notes:

1. Maintain a minimum of 3 tight wraps of wire rope on the drum at all times.
2. For pulling applications, ensure top layer of wire rope is at least 1/2 in. (13 mm) below edge of drum flange.
- A. For correct fleet angle, maintain a minimum of 1.6 feet (0.5 metre) per inch of drum length. Example: for a 7 inch drum length, locate the lead sheave at least 11.2 feet (3.5 metres) from drum.

Wire Rope

⚠ CAUTION

- **Maintain at least 3 tight wraps of wire rope on the drum at all times. Refer to Dwg. MHP0498 on page 7.**

Wire Rope Selection

Consult a reputable wire rope manufacturer or distributor for assistance in selecting the appropriate type and size of wire rope and, where necessary, a protective coating. Use a wire rope which provides an adequate safety factor to handle the actual working load and that meets all applicable industry, trade association, federal, state and local regulations.

When considering wire rope requirements the actual working load must include not only the static or dead load but also loads resulting from acceleration, retardation and shock load. Consideration must also be given to the size of the winch wire rope drum, sheaves and method of reeving. Wire rope construction must be 6 X 19 or 6 X 37 IWRC right lay. Refer to Table 1 for minimum and maximum recommended wire rope diameters.

Table 1 - Minimum and Maximum Wire Rope Size

Model	Minimum		Maximum	
	inch	mm	inch	mm
EU	5/16	8	7/16	11
EUL				

For winches used in **lifting** applications, ensure that the top layer of the wire rope is a distance from the top of the drum flange that is equal to at least twice the diameter of the wire rope. For example: the top layer of a 10 mm wire rope must be at least 20 mm below the drum flange edge.

Installing Wire Rope

Refer to Dwg. MHP1334 on page 8.

1. Cut wire rope to length and fuse end to prevent fraying of strands in accordance with the wire rope manufacturer's instructions.
2. Feed the fused end of the wire rope into the wire rope anchor hole, past the two anchor screws, and position the end just beneath the drum surface.
3. Apply the wire rope so that it winds over the top when the drum is rotated in a direction that is counterclockwise when facing the motor end of the winch. This is indicated by an arrow on the motor case.
4. Secure by tightening anchor screws.

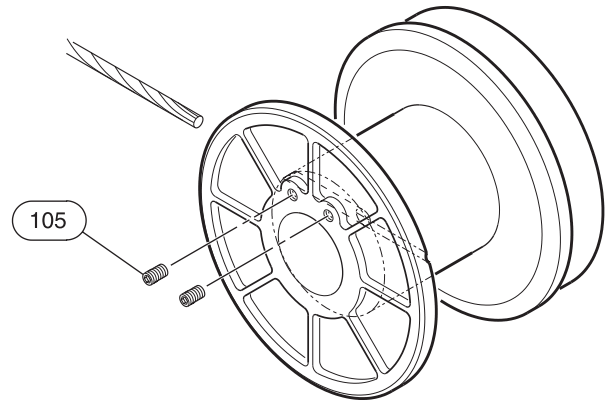

(Dwg. MHP1334)

⚠ CAUTION

- **Ensure the first wrap of wire rope is tight and lies flush against the drum flange.**
- **The wire rope should be applied to the drum so that it overwinds when the drum rotates in a clockwise direction when facing the gear end of the winch. This is indicated by an arrow on the gear case.**

Safe Wire Rope Handling Procedures

1. Always use gloves when handling wire rope.
2. Never use wire rope which is frayed or kinked.
3. Never use wire rope as a sling.
4. Always ensure wire rope is correctly spooled and the first layer is tight against the drum.
5. Always follow wire rope manufacturer's recommendations on use and maintenance of wire rope.

Wire Rope Spooling

To compensate for uneven spooling and the decrease in line pull capacity as the drum fills up, use as short a wire rope as practical. When rewinding apply tension to the end of the wire rope to eliminate line slack. This helps achieve level winding and tight spooling.

Rigging

Make sure all wire rope blocks, tackle and fasteners have a sufficient safety margin to handle the required load under all conditions. Do not allow wire rope to contact sharp edges or make sharp bends which will cause damage to wire rope, **use a sheave**. Refer to the wire rope manufacturer's handbook for proper sizing, use and care of wire rope.

Safe Installation Procedures

1. Do not use wire rope as a ground (earth) for welding.
2. Do not attach a welding electrode to winch or wire rope.
3. Never run the wire rope over a sharp edge. Use a correctly sized sheave.
4. When a lead sheave is used, it must be aligned with the center of the drum. Refer to Dwg. MHP0498 on page 7. The diameter of the lead sheave must be at least 18 times the diameter of the wire rope.
5. Always maintain at least three full, tight wraps of wire rope on the drum.

Air Supply

Air supply must be clean, free from moisture and lubricated to ensure optimum motor performance. Foreign particles, moisture and lack of lubrication are the primary causes of premature motor wear and breakdown. Using an air filter, lubricator and moisture separator will improve overall winch performance and reduce unscheduled downtime.

The air consumption is 65 scfm (1.8 cu.m/min.) at rated operating pressure of 90 psig (6.3 bar/630 kPa) at the winch motor inlet. If the air supply varies from what is recommended, winch performance will change.

Air Lines

The inside diameter of winch air supply lines must not be less than the size shown in Table 2 on page 9. Prior to making final connections, all air supply lines should be purged with clean, moisture free air or nitrogen before connecting to winch inlet. Supply lines should be as short and straight as installation conditions will permit. Long transmission lines and excessive use of fittings, elbows, tees, globe valves etc. cause a reduction in pressure due to restrictions and surface friction in the lines.

Table 2 - Minimum Allowable Air Supply Line Sizes

Model	inch	mm
EU	1	25
EUL		

Air Line Lubricator

Refer to Dwg. MHP0191 on page 9. Always use an air line lubricator with these motors. The lubricator must have an inlet and outlet at least as large as the inlet on the motor. Install the air line lubricator as close to the air inlet on the motor as possible.



- **Lubricator must be located no more than 10 ft. (3 m) from the motor.**

Air line lubricator should be replenished daily and set to provide 6 to 12 drops per minute of ISO VG 32 (10W) oil. A fine mist will be exhausted from the throttle control valve when air line lubricator is functioning properly.

Air Line Filter

Refer to Dwg. MHP0191 on page 9. It is recommended that an air line strainer/filter be installed as close as practical to the motor air inlet port, but before the lubricator, to prevent dirt from entering the motor. The strainer/filter should provide 20 micron filtration and include a moisture trap. Clean the strainer/filter periodically to maintain its operating efficiency.

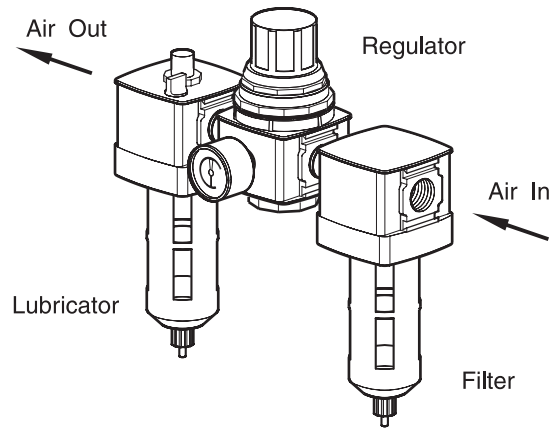

(Dwg. MHP0191)

Moisture in Air Lines

Moisture that reaches the air motor through air supply lines is a primary factor in determining the length of time between service overhauls. Moisture traps can help to eliminate moisture. Other methods, such as an air receiver which collects moisture before it reaches the motor, an aftercooler at the compressor that cools the air to condense and collect moisture prior to distribution through the supply lines are also helpful.

Motor

For optimum performance provide an air supply of 90 psig at 65 scfm (6.3 bar/630 kPa at 1.8 cu. m/m). The air motor should be installed as near as possible to the compressor or air receiver. Recommended pressures and volumes are measured at the point of entry to the air motor.

Initial Operating Checks

Winches are tested for proper operation prior to leaving factory. Before winch is placed into service the following initial operating checks should be performed.

1. When first running the motor, inject some light oil into the inlet connection to provide initial lubrication.
2. When first operating winch it is recommended that the motor be driven slowly in both directions for a few minutes.

Start-Up Procedures

For winches that have been in storage for a period of more than one month, the following start-up procedure is required:

1. Give the winch an inspection conforming to requirements listed in "Winches Not in Regular Use" in the "INSPECTION" section.
2. Pour a small amount of ISO VG 32 (10W) oil in the motor inlet port.
3. Operate the motor for 10 seconds in both directions to flush out any impurities.
4. The winch is now ready for normal use.

OPERATION

The four most important aspects of winch operation are:

1. Follow all safety instructions when operating the winch.
2. Allow only people trained in safety and operation of this winch to operate this equipment.
3. Subject each winch to a regular inspection and maintenance procedure.
4. Be aware of the winch capacity and weight of load at all times.

⚠ CAUTION

- Only allow personnel instructed in safety and operation to operate a winch.
- To avoid damage to the rigging, the structure supporting the rigging and the winch, do not “two-block” the end of the wire rope.

* Two-blocking occurs when the winch wire rope is multi-reeved using two separate sheave blocks which are allowed to come into contact with each other during winch operation. When this occurs, extreme forces are exerted on the wire rope and sheave blocks, which may result in equipment and/or rigging failure.

⚠ WARNING

- The winch is not designed or suitable for lifting, lowering or moving persons. Never lift loads over people.

Operators must be physically competent and have no health condition which might affect their ability to act. They must have good hearing, vision and depth perception. The winch operator must be carefully instructed in his duties and must understand the operation of the winch, including a study of the manufacturer’s literature. The operator must thoroughly understand proper methods of hitching loads and must have a good attitude regarding safety. It is the operator’s responsibility to refuse to operate the winch under unsafe conditions.

Winch Controls

The spring loaded, motor mounted, manual throttle control valve is standard to, and normally supplied with, this winch. Optional motor throttle controls are available. Refer to the model code on the winch nameplate and compare it to the “SPECIFICATIONS” section of this manual to determine your configuration. The throttle controls provide operator control of the motor speed and direction of drum rotation.

Winch Mounted Live Air Throttle

(Standard feature)

The spring loaded manual control throttle mounts to the air motor. When viewed from the air motor end move the control throttle handle to the left (counterclockwise) to payout wire rope and to the right (clockwise) to haul-in wire rope.

To ensure smooth operation of the winch sudden movements of the control valve should be avoided.

Remote Live Air Pendant Throttle (optional feature)

Refer to Dwg. MHP2233 on page 10.

Provides for remote winch control at distances of up to *15 feet (4.5 metres) away from the winch. The pendant control throttle is a two lever movable control station for winch operation. The winch control valve, located on the winch motor, controls the motor speed and direction of drum rotation. Direction of rotation is determined by the pendant lever depressed.

* For distances greater than 15 feet (4.5 metres) contact Technical Sales for control acceptability.

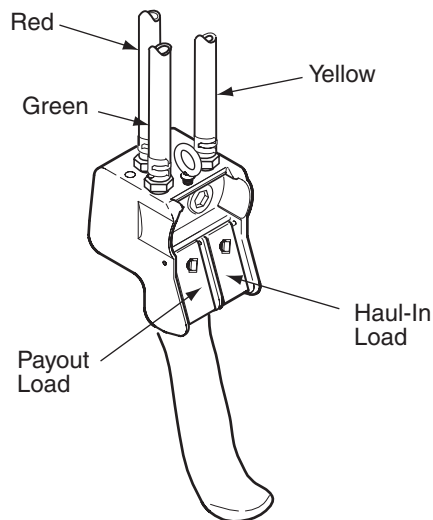

(Dwg. MHP2233)

Winch Brakes

Manual Drum Brake

To apply the manual drum brake, turn the brake lever (77) clockwise. Rotate brake lever counterclockwise to release. The brake must be kept properly adjusted to hold the required load.

Automatic Drum Brake

The optional automatic drum brake is a spring-applied, air released, externally mounted cylinder. When the motor is operated in either the haul-in or payout direction, air pressure directed to the cylinder overcomes spring pressure to release the brake. When the control valve is in the neutral position, air in the cylinder is vented. This allows the spring to engage the brake.

Free Spool Clutch

⚠ CAUTION

- Do not engage clutch when motor is running or drum is spinning, as this produces a severe strain on parts.
- Do not disengage clutch when winch is loaded. Be sure clutch is fully engaged before operating winch.

A jaw type clutch connects the gearing and drum. The function of the clutch is to disengage the rope drum from the motor so that the wire rope can be unwound from the drum by hand without working against the gearing and the compression of the motor. The clutch is engaged or disengaged by the clutch lever (73) which is located on the top of the gear case section of the winch base. When clutch is engaged the lever is locked by a detent to prevent disengagement. Detent is released by pressing down (toward base) on lever, after which the end can be swung outward from the winch, disengaging the clutch jaws. When clutch is in disengaged position it can be engaged by moving end of lever toward winch. It may be necessary to open the throttle a slight amount to position the jaws for engagement.

⚠ WARNING

- **Do not use free spool clutch feature in combination with automatic brake. Use of winches with free spool clutch and automatic brake can result in severe injury, death or property damage.**

For winches equipped with an automatic brake, always ensure that clutch jaw spacer (90) is installed.

INSPECTION

Inspection information is based in part on American National Standards Institute Safety Codes (ASME B30.7).

⚠ WARNING

- **All new or repaired equipment should be inspected and tested by personnel instructed in safety, operation and maintenance of this equipment to ensure safe operation at rated specifications before placing equipment in service.**
- **Never use a winch that inspection indicates is damaged.**

Frequent and periodic inspections should be performed on equipment in regular service. Frequent inspections are visual examinations performed by operators or personnel trained in safety and operation of this equipment and include observations made during routine winch operation. Periodic inspections are thorough inspections conducted by personnel trained in the safety, operation and maintenance of this equipment.

ASME B30.7 states inspection intervals depend upon the nature of the critical components of the equipment and the severity of usage. The inspection intervals recommended in this manual are based on intermittent operation of the winch eight hours each day, five days per week, in an environment relatively free of dust, moisture and corrosive fumes. If the winch is operated almost continuously or more than the eight hours each day, more frequent inspections will be required.

Careful inspection on a regular basis will reveal potentially dangerous conditions while still in the early stages, allowing corrective action to be taken before the condition becomes dangerous.

Deficiencies revealed through inspection, or noted during operation, must be reported to designated personnel instructed in safety, operation and maintenance of this equipment. A determination as to whether a condition constitutes a safety hazard must be made, and the correction of noted safety hazards accomplished and documented by written report before placing the equipment in service.

Records and Reports

Inspection records, listing all points requiring periodic inspection should be maintained for all load bearing equipment. Written reports, based on severity of service, should be made on the condition of critical parts as a method of documenting **periodic** inspections. These reports should be dated, signed by the person who performed the inspection, and kept on file where they are readily available for review.

Wire Rope Reports

Records should be maintained as part of a long-range wire rope inspection program. Records should include the condition of wire rope removed from service. Accurate records will establish a relationship between visual observations noted during frequent inspections and the actual condition of wire rope as determined by periodic inspections.

Frequent Inspection

On equipment in continuous service, frequent inspection should be made by operators at the beginning of each shift. In addition, visual inspections should be conducted during regular operation for damage or evidence of malfunction.

1. **WINCH.** Prior to operation, visually inspect housings, control, brake and drum for indications of damage. Do not operate winch unless wire rope feeds onto drum smoothly. Any discrepancies noted must be reviewed and inspected further by authorized personnel instructed in the operation, safety and maintenance of this winch.
2. **WIRE ROPE.** Visually inspect all wire rope which can be expected to be in use during the day's operations. Inspect for wear and damage indicated by distortion of wire rope such as kinking, "birdcaging," core protrusion, main strand displacement, corrosion, broken or cut strands. If damage is evident, do not operate winch until the discrepancies have been reviewed and inspected further by personnel knowledgeable on wire rope safety and maintenance procedures.

NOTICE

- **The full extent of wire rope wear cannot be determined by visual inspection. At any indication of wear inspect the wire rope in accordance with instructions in "Periodic Inspection."**

3. **WIRE ROPE REEVING.** Check reeving and ensure wire rope is properly secured to the drum. Do not operate the winch unless the wire rope feeds onto the drum smoothly.
4. **AIR SYSTEM.** Visually inspect all connections, fittings, hoses and components for indication of air leaks. Repair any leaks or damaged components found. If winch responds slowly or movement is unsatisfactory, do not operate until all problems have been corrected.

5. BRAKE. During winch operation, test the brake. Brake must be capable of supporting the load without slipping. The automatic brake must release when the winch throttle is operated. If the brake does not hold or does not release properly, the brake must be adjusted or repaired.
6. LUBRICATION. Refer to "LUBRICATION" section for recommended procedures and lubricants.
7. MANUAL THROTTLE LEVER. Ensure operation of manual throttle lever is smooth and winch is responsive to lever movement. Lever must return to neutral when released.
8. PENDANT (optional feature). Ensure operation of pendant levers is smooth and that the winch is responsive to pendant control. Pendant levers must spring back to their starting position when released.
9. MOTOR. Check oil level. Place a suitable container below the motor and carefully open the drain plug to remove any accumulated water. Check oil level in motor and add oil as necessary to maintain correct level. Ensure lubricated air supply provides 6 to 12 drops of ISO VG 32 (10W) oil. Operate winch slowly in both directions to verify operation.

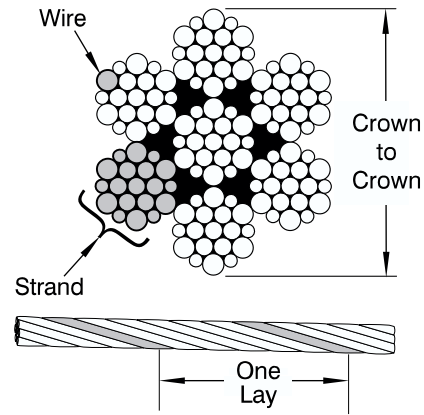

(Dwg. MHP0056)

Periodic Inspection

According to ASME B30.7, frequency of periodic inspection depends on the severity of usage:

NORMAL	HEAVY	SEVERE
yearly	semiannually	quarterly

Disassembly may be required as a result of frequent inspection findings or in order to properly inspect the individual components. Refer to "MAINTENANCE" section on page 16. Maintain written records of periodic inspections to provide an accumulative basis for continuing evaluation. Inspect all items listed in "Frequent Inspection." Also inspect the following:

1. FRAMES, CASES AND BRACKETS. Check for deformed, cracked or corroded main components. Replace damaged parts.
2. FASTENERS. Check retainer rings, split pins, capscrews, nuts, and other fasteners on winch, including mounting bolts. Replace if missing or damaged and tighten if loose.
3. DRUM AND SHEAVES. Check for cracks, wear or damage. Replace if necessary.
4. WIRE ROPE. In addition to frequent inspection requirements, also inspect for the following:
 - a. Build-up of dirt and corrosion. Clean with steam or a stiff wire brush to remove dirt and corrosion if necessary.
 - b. Loose or damaged end connection. Replace if loose or damaged.
 - c. Check wire rope is anchored securely in drum.
 - d. Verify wire rope diameter. Measure the diameter of the wire rope from crown to crown throughout the life of the wire rope. Recording of the actual diameter should only be done with the wire rope under equivalent loading and in the same operating section as accomplished during previous inspections. If the actual diameter of the wire rope has decreased more than 1/64 inch (0.4 mm) a thorough examination of the wire rope should be conducted by an experienced inspector to determine the suitability of the wire rope to remain in service. Refer to Dwg. MHP0056 on page 12.

5. ALL COMPONENTS. Inspect for wear, damage, distortion, deformation and cleanliness. If external evidence indicates damage, disassemble as required to conduct a detailed inspection. Inspect gears, shafts, bearings, sheaves, springs and covers. Replace worn or damaged parts. Clean, lubricate and reassemble.
6. BRAKE. Test brake to ensure proper operation. Brake must hold a **125% rated load** with full drum without slipping. If indicated by poor operation or visual damage, disassemble and repair brake. Check all brake surfaces for wear, deformation or foreign deposits. When rivet heads are flush with lining, replace brakes. Clean and replace components as necessary. Refer to the "MAINTENANCE" section for adjustment information.
7. SUPPORTING STRUCTURE. Check for distortion, wear and continued ability to support winch and rated load. Ensure winch is firmly mounted and that fasteners are in good condition and tight.
8. LABELS AND TAGS. Check for presence and legibility of labels. Replace if damaged or missing.

Winches Not in Regular Use

1. Equipment which has been idle for a period of one month or more, but less than six months, shall be given an inspection conforming to the requirements of "Frequent Inspection" before being placed in service.
2. Equipment which has been idle for a period of over six months shall be given a complete inspection conforming with the requirements of "Periodic Inspection" before being placed in service.
3. Standby equipment shall be inspected at least semiannually in accordance with the requirements of "Frequent Inspection." In abnormal operating conditions equipment should be inspected at shorter intervals.

INSPECTION AND MAINTENANCE REPORT

Ingersoll-Rand Models EU and EUL Air Winch

Model Number:	Date:
Serial Number:	Inspected by:

Reason for Inspection: (Check Applicable Box)

1.	Scheduled Periodic Inspection (___ Monthly ___ Semiannually ___ Yearly)	Operating Environment: Normal ___ Heavy ___ Severe ___
2.	Discrepancy(ies) noted during Frequent Inspection	
3.	Discrepancy(ies) noted during maintenance	
4.	Other: _____	

Refer to the Parts, Operation and Maintenance Manual "INSPECTION" section for general inspection criteria. Also, refer to appropriate National Standards and codes of practice. If in doubt about an existing condition, contact the nearest **Ingersoll-Rand** Distributor or the factory for technical assistance.

COMPONENT	CONDITION		CORRECTIVE ACTION		NOTES
	Pass	Fail	Repair	Replace	
Case, Frame & Motor Mounting Bracket					
Drum Band Brake (125% Load Test)					
Drum Band Brake (Visual Inspection)					
Motor					
Controls					
Air System					
Fasteners					
Reduction Gears					
Clutch					
Labels and Tags			---		
Shafts					
Wire Rope			---		
Other Components (list in NOTES section)					

TESTING	Pass	Fail	NOTES
Operational (No Load)			
Operational (10% Load)			
Operational (Maximum Test Load *)			

* Maximum test load is 125% of rated line pull. Testing to more than 125% of rated load may be required to comply with standards and regulations set forth in areas outside the USA.

This form may be copied and used as an inspection/maintenance record.

LUBRICATION

To ensure continued satisfactory operation of the winch, all points requiring lubrication must be serviced with the correct lubricant at the proper time interval as indicated for each assembly.

The lubrication intervals recommended in this manual are based on intermittent operation of the winch eight hours each day, five days per week. If the winch is operated almost continuously or more than the eight hours each day, more frequent lubrication will be required. Also, the lubricant types and change intervals are based on operation in an environment relatively free of dust, moisture, and corrosive fumes. Use only those lubricants recommended. Other lubricants may affect the performance of the winch. Approval for the use of other lubricants must be obtained from your **Ingersoll-Rand** distributor. Failure to observe this precaution may result in damage to the winch and/or its associated components.

INTERVAL	LUBRICATION CHECKS
Start of each shift	Check flow and level of air line lubricator (approximately 6 to 12 drops per minute required at maximum motor speed).
	Check oil level in the motor.
Monthly	Inspect and clean or replace air line filter.
Yearly	Replace grease in gear case.
	Drain and refill the oil in the winch motor.

Motor

Winch is shipped from factory with oil. Correct lubrication is one of the most important factors in maintaining efficient winch operation. The motor is splash lubricated by the oil in the motor housing and has no other means of lubrication. It is therefore important to use only high quality, Extreme Pressure (EP) rust- and oxidation-inhibiting gear oils or non-detergent motor oils to ensure maximum performance and minimum downtime for repairs. Refer to Table 3. Allow oil to settle before topping off. Oil capacity for winch motor is 1 quart (0.95 litres). Pour sufficient oil into the vent cap opening to bring the oil in the motor case to the level of the upper oil plug hole. Add oil slowly to prevent spilling.

Table 3 - Recommended Oil

Ambient Temperature	Recommended Oil Type
Below 32° F (0° C)	ISO VG 32 (10W)
30° to 80° F (0° to 26° C)	ISO VG 68 (20W)
Above 80° F (26° C)	ISO VG 100 (30W)

The oil level in the motor should be checked daily or at the start of each shift after accumulated water has been drained off. Remove side plug (13) to drain water. When motor is operated in temperatures below freezing, wait long enough at end of shift for water to separate from oil but not long enough for it to freeze.

Failure to drain the water when the winch is to remain idle for a protracted period at low temperatures may result in freezing of the oil splasher (68), which is attached to the crank (52). Drain the water, then refill to the level plug. If desired, all the oil may be drained at the end of the shift and the motor refilled with new oil.

Drain and replace oil in the motor and reduction gear after the first 50 hours of winch operation. Thereafter, drain and replace oil according to the intervals recommended.

Always inspect removed oil for evidence of internal damage or contamination (metal shavings, dirt, water, etc.). If indications of damage are noticed, investigate and correct before returning winch to service.

After winch operation, allow oil to settle before topping off.

Always collect lubricants in suitable containers and dispose of in an environmentally safe manner.

Gear Case Lubrication

Check the grease in the gear chamber weekly by removing the grease plug (15) in the top section of the winch base (94). If the visible portion of the gears is not covered with a film of grease and the gears appear to lack lubrication, add about half a pint (237 ml) of **Ingersoll-Rand** Heavy Gear Grease No. 70. **Ingersoll-Rand** Light Grease No. 28 or a soda base or mixed base grease of No. 2 consistency may be used as a substitute.

Seals and Bearings

If winch is disassembled, clean all parts thoroughly and coat bearings and seals with clean grease. Refer to Table 4. Use sufficient grease to provide a good protective coat.

Table 4 - Recommended Grease

Ambient Temperature	Recommended Grease Type
-20° to 50° F (-30° to 10° C)	EP 1 multipurpose lithium-based
30° to 120° F (-1° to 49° C)	EP 2 multipurpose lithium-based

Wire Rope

Follow the wire rope manufacturer's instructions. At a minimum, observe the following guidelines.

1. Clean with a brush or steam to remove dirt, rock dust or other foreign material on the surface of the wire rope.



• **Do not use an acid-based solvent. Only use cleaning fluids and lubricants specified by the wire rope manufacturer.**

2. Apply a wire rope lubricant, LUBRI-LINK-GREEN® or ISO VG 100 (30W) oil.
3. Brush, drip or spray lubricant weekly, or more frequently, depending on severity of service.

TROUBLESHOOTING

This section provides basic troubleshooting information. Determination of specific causes to problems are best identified by thorough inspections performed by personnel instructed in safety, operation and maintenance of this equipment. The chart below provides a brief guide to common winch symptoms, probable causes and remedies.

SYMPTOM	CAUSE	REMEDY
Winch will not operate.	No air supply to winch.	Check air supply line connections and hoses.
	Winch is overloaded.	Reduce load to within rated capacity.
	Brake is not released.	Disengage manual brake or refer to "Automatic Drum Brake" below.
Load continues to move when winch is stopped.	Brake is slipping.	Check brake adjustment and brake band lining wear.
Winch does not lift load.	Motor may be damaged.	Remove and disassemble motor as described in the "MAINTENANCE" section on page 16. Examine all parts and replace any that are worn or damaged.
	Insufficient air supply.	Verify air supply pressure and volume at winch inlet meets the requirements listed in the "SPECIFICATIONS" section on page 5. Clean air line filter.
	Winch is overloaded.	Reduce load to within rated capacity.
Throttle (or pendant) lever moves but winch does not operate.	Motor may be damaged.	Disassemble and clean the motor and replace any broken or damaged parts.
	Insufficient air supply.	Ensure the air pressure at the winch inlet is at least 90 psig (6.3 bar/630 kPa) at rated volume. Clean air line filter.
Motor runs hot or makes excessive noise during operation.	Low oil level.	Check oil level in the motor. Drain or add oil as required to obtain the proper level.
	Improper lubrication.	Replace oil with type recommended in the "LUBRICATION" section on page 14, applicable to the operating environment. Set lubricator to provide a minimum of 6 drops per minute. Check oil level in the lubricator.
	Water in oil.	Drain and refill with oil. Operate winch with no load slowly, in both directions. If excessive noise is present or motor overheats, disassemble and repair motor.
	Damaged or broken piston or connecting rod.	Disassemble and repair motor.
Winch runs slow.	Improper hose or fitting sizes.	Check fittings, connections and hoses for correct size and length. Replace parts that may cause restricted air flow. Inspect air line filter.
	Motor may be damaged.	Remove and disassemble motor as described in the "MAINTENANCE" section on page 16. Inspect all parts and replace all worn or damaged parts.
Air lines freeze.	Water in air supply.	Install or drain air system moisture traps, moisture collecting air receivers and compressor aftercoolers. After corrective actions have been taken, disconnect lines at winch inlet and purge with clean, dry air or nitrogen prior to attaching to and operating winch.

Automatic Drum Brake:

Brake will not release.	Drum brake out of adjustment.	Adjust drum brake to maintain correct cylinder stroke.
	Damaged piston rings.	If air is noticed escaping from the bleed valves when attempting to release the brake replace or repair cylinder.
	Dirty filter in air supply.	Clean or replace filter.
	Dump valve plugged.	Clear foreign material out of dump valve. Air should exhaust when control valve handle is activated in either direction.

MAINTENANCE

⚠ WARNING

- Never perform maintenance on the winch while it is supporting a load.
- Before performing maintenance, tag controls:
WARNING - DO NOT OPERATE - EQUIPMENT BEING REPAIRED.
- Only allow service personnel trained in safety and maintenance on this winch to perform maintenance.
- After performing any maintenance on the winch, test winch to 125% of its rated capacity before returning to service.
- Shut off air system and depressurize air lines before performing any maintenance.

Maintenance Intervals

The Maintenance Interval Chart below is based on intermittent operation of equipment for eight hours each day, five days per week. If the equipment is in operation for more than eight hours a day or is operated in severe applications or environments, more frequent maintenance should be performed.

INTERVAL	MAINTENANCE CHECK
Start of each shift (Operator or Maintenance Personnel)	Make a thorough visual inspection of the winch for damage. Do not operate winch if damaged.
	Operate the winch at low RPM in both directions. Winch must operate smoothly without sticking, binding or abnormal noises. Check operation of brake(s).
3 Months (Maintenance Personnel)	Inspect the brake linings. Clean or replace parts as required. Adjust brake as necessary.
Yearly (Maintenance Personnel)	Inspect winch gearing, shafts and bearings for wear and damage. Repair or replace as necessary.
	Check all supporting members, including foundation, fasteners, nuts, sheaves and rigging, etc. for indications of damage or wear. Repair or replace as required.

Adjustments

Manual Brake

Refer to Dwg. MHP1214 on page 20.

⚠ CAUTION

- Before adjusting brake, remove any load from load line to prevent injury or property damage.
1. Remove cotter pin (78) and reposition brake lever (77) so that turning the lever clockwise draws more of the brake screw (99) up through the brake adjusting nut (79) and tightens the brake band (101).

Automatic Brake

Refer to Dwg. MHP1215 on page 24.

⚠ CAUTION

- Shut off air supply before adjusting automatic brake.
1. Remove capscrews (144), washers (145) and brake cylinder head (146).
 2. Insert the two prongs of the **Ingersoll-Rand** No. R55R-26 brake adjusting wrench into the two holes in the top of brake piston (157).
 3. Move wrench in a clockwise direction to rotate piston until it projects 3/4 to 7/8 inches (19 - 23 mm) above the face of the brake cylinder case (148).
 4. Replace cylinder head and tighten capscrews. Supply air to engage brake. Shut off air supply and repeat steps 1 through 3 if brake does not hold load.

Disassembly

General Disassembly Instructions

The following instructions provide necessary information to disassemble, inspect, repair, and assemble winch. Parts drawings are provided in the parts section. In general, winch is designed to permit easy disassembly and assembly. The use of heat or excessive force should not be required. If a winch is being completely disassembled for any reason, follow the order of the topics as they are presented. It is recommended that all maintenance work on winch be performed in a clean dust free work area.

In the process of disassembling winch, observe the following:

1. Never disassemble winch any further than is necessary to accomplish the needed repair. A good part can be damaged during the course of disassembly.
2. Never use excessive force when removing parts. Tapping gently around the perimeter of a cover or housing with a soft hammer, for example, is sufficient to break the seal.
3. Do not heat a part with a flame to free it for removal, unless the part being heated is already worn or damaged beyond repair and no additional damage will occur to other parts.
4. Keep work area as clean as practical, to prevent dirt and other foreign matter from getting into bearings or other moving parts.
5. All seals, gaskets and 'O' rings should be discarded once they have been removed. New seals, gaskets and 'O' rings should be used when assembling winch.
6. When grasping a part in a vise, always use leather- or copper-covered vise jaws to protect the surface of the part and help prevent distortion. This is particularly true of threaded members and housings.
7. Do not remove any part which is a press fit in or on a subassembly unless the removal of that part is necessary for repairs or replacement.
8. When removing ball bearings from shafts, it is best to use a bearing puller. When removing bearings from housings, drive out bearing with a sleeve slightly smaller than the outside diameter of the bearing. The end of the sleeve or pipe which contacts the bearing must be square. Protect bearings from dirt by keeping them wrapped in clean cloths.

NOTICE

- **Special attention should be given to installation of needle bearings. Pressing or driving directly on bearing may result in the distortion or fracture of its thin shell, with subsequent early failure as a result.**
- **Bearings should be pressed in with a bearing insertion tool that is shaped to properly contact the bearing face.**
- **Do all pressing on the stamped face of the bearing.**

The construction of the winch allows for motor to be removed, repaired and replaced without removing the gearing.

Alternatively, the gearing can be removed and replaced without disturbing the motor.

The following instructions cover the complete disassembly of the winch. For sub-assemblies where it is obvious that no new parts are required, do not disassemble. Even for complete reconditioning, disassembly should proceed only far enough to allow through inspection and replacement of worn and damaged parts.

Brake Band Replacement

When rivet head becomes exposed, replace brake band lining.

Manual Brake

Refer to Dwg. MHP1214 on page 20.

1. Turn brake handle (77) counterclockwise until brake screw (99) disengages from brake adjusting nut (79).
2. Remove cotter pin (78) and brake screw guide (93).
3. Remove all four drum cover screws (107) and washers (4).
4. Take out grease fitting (14) and pull drum cover (109) off.
5. Remove drum (104) from base (94).
6. Remove the cotter pin (97) from the brake band pin (98). Tip the winch and tap lightly to dislodge brake band pin.
7. Push brake screw down until it is clear of the hole in top of base. Pull off brake band (101) with brake screw attached.
8. Install new brake band by first inserting brake screw up into hole.
9. Insert brake band pin through both the slot in the end of the brake band and the corresponding hole in the top of the base. Secure with cotter pin.
10. Slide the drum onto the base. Replace the drum cover, washers, drum cover screws and grease fitting.
11. Screw the adjusting nut and handle onto the brake adjusting screw.

Automatic Brake

Refer to Dwg. MHP1215 on page 24.

1. Turn off air supply and unscrew pipe connection (141).
2. Remove capscrews (144) and washers (145) and take off brake cylinder head (146).
3. Insert prongs of **Ingersoll-Rand** brake adjusting wrench R55R-26 into holes in top of piston (157) and turn anticlockwise until brake trunnion unscrews out of brake screw coupling (152) and the spring (153) is released.
4. Remove cylinder case screw (162) and lift cylinder assembly off the base (94).
5. Remove screw coupling from brake adjusting screw (99).
6. Follow instructions 3 through 10 for manual brake band replacement.
7. Screw the brake screw coupling onto the brake screw.
8. Place the cylinder over the coupling with the assembled parts.

9. Using the brake adjusting wrench, rotate the piston until it projects 3/4 to 7/8 inches (19 - 23 mm) above the face of the brake cylinder case (148). Refer to Dwg. MHP1475 on page 17.

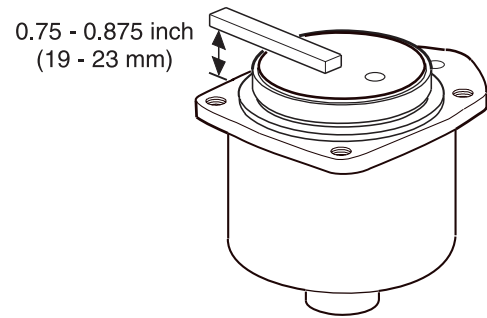

(Dwg. MHP1475)

10. Replace the cylinder, capscrews and lockwashers.
11. Reconnect the air supply hose and operate the unit to check that the brake holds a load.
12. If brake does not hold load properly, repeat instructions 1 through 11.

Motor Disassembly

Refer to Dwg. MHP1214 on page 20.

1. Unscrew the four valve chest cover capscrews (2 and 3) and remove the cover (5).
2. Screw a No. D02-932 jack bolt into each tapped lug on the valve chest until the jack bolts contact the motor case (47). Turn each jack bolt a little at a time to jack the valve chest from the motor case.
3. Unscrew the throttle valve cap (16) and remove the spring (18), poppet throttle valve (19) and ball (21) from the valve chest.
4. Withdraw the rotary valve (25), reverse valve (27) and throttle lever spring (34).
5. Support the face of the valve chest that contacts the motor case and press out the old bushings with an arbor.

CAUTION

- **Use an arbor that will clear the bushing key (8) that project into the bushing bore in valve chest. Pressing bushings out in the opposite direction or using an arbor that will not clear the bushing key will result in the key being sheared off.**

6. To remove the motor case (47) from the motor case cover (81), unscrew the six long motor case capscrews (48) which retain both to the gear housing section of the base (94). Remove the two short capscrews (39) which retain the motor case on the motor case cover. The three medium-length capscrews (112) which keep the motor case cover on the gear housing need only be removed to allow access to the gears and motor shaft.
7. Unscrew the four capscrews (43) from any one of the four cylinder heads (45) and remove the cylinder head and gasket (46).
8. Rotate the crank (52) until the piston (57) is at top dead center. Push piston wrist pin (58) out of piston, freeing piston from connecting rod (61). Repeat until all four cylinders and pistons have been removed, freeing the crank and assembled parts.
9. Using two screw drivers, pry the crank pin sleeve (65) from the crank and remove the connecting rod rings (62), connecting rods and connecting rod bushing (64).

Gear Case Disassembly

Refer to Dwg. MHP1214 on page 20.

1. Remove the clutch latch pin (72), clutch latch (69), spring (71) and clutch lever (73) from the top of the gear case section of the base (94).
2. Unscrew gear case plug (15), tip winch upside down and allow grease to drain.
3. Place the winch, drum side toward work surface, on wooden supports. Unscrew the three capscrews (112) that hold the motor case cover (81) onto the gear case section.
4. Loosen the motor case cover by gently prying it from the gear housing, taking care not to compromise its fit by damaging its edges.
5. Remove pin (83) from clutch jaw and pin (114) from intermediate gear shaft (115). Grasp the intermediate gear (118) and motor shaft pinion (85) and withdraw the motor shaft assembly and intermediate gear assembly simultaneously from the gear housing.

Wire Rope Drum Removal

Refer to Dwg. MHP1214 on page 20 and MHP1215 on page 24.

1. Remove grease fitting (14) and drain grease.
2. Unscrew all four drum cover screws (107) and washers (4) and pull drum cover (109) off.
3. Turn manual brake handle counterclockwise to loosen brake band (101). For models with automatic brake, remove the four capscrews (144), washers (145) and brake cylinder head (146). Insert brake adjusting wrench R55R-26 into holes in piston (157) and rotate anticlockwise.
4. When brake band is loose, remove drum (104) from base (94).

Cleaning, Inspection and Repair

Cleaning

Clean all winch component parts in solvent (except the drum brake bands and disc brake friction plates). The use of a stiff bristle brush will facilitate the removal of accumulated dirt and sediments on the housing, frame and drum. If bushings have been removed, it may be necessary to carefully clean out old Loctite® from the bushing bores. Dry each part using low pressure, filtered compressed air. Clean the drum brake band using a wire brush or emery cloth. Do not wash the drum brake band in liquid. If the drum brake band lining is oil-soaked, it must be replaced.

Inspection

All disassembled parts should be inspected to determine their fitness for continued use. Pay particular attention to the following:

1. Inspect all gears for worn, cracked, or broken teeth.
2. Inspect all bushings for wear, scoring, or galling.
3. Inspect shafts for ridges caused by wear. If such ridges are apparent on shafts, replace the affected shafts.
4. Inspect all threaded items and replace any with damaged threads.
5. Inspect the drum band brake lining for oil, grease and glazing. If the drum band brake lining is oil-soaked, replace the brake band. Remove glazed areas of band brake lining by sanding lightly with a fine grit emery cloth.
6. Measure the thickness of the drum band brake lining. If the brake band lining is less than 0.062 inch (2 mm) thick anywhere along the edges, replace the brake band (16).

Repair

Actual repairs are limited to the removal of small burrs and other minor surface imperfections from the gears and shafts. Use a fine stone or emery cloth for this work.

1. Worn or damaged parts must be replaced. Refer to the applicable parts listing for specific replacement parts information.
2. Inspect all remaining parts for evidence of damage. Replace or repair any part that is in questionable condition. The cost of the part is often minor in comparison to the cost of redoing the job.
3. Smooth out all nicks, burrs, or galled spots on shafts, bores, pins, or bushings.
4. Examine all gear teeth carefully and remove nicks or burrs.
5. Polish the edges of all shaft shoulders to remove small nicks which may have been caused during handling.
6. Remove all nicks and burrs caused by lockwashers.

Assembly

General Instructions

1. Use all new gaskets, seals and 'O' rings.
2. Replace worn parts.
3. Assemble parts using match marks attached during disassembly. Compare replacement parts with originals to identify installation alignments.
4. Lubricate all internal parts with a mixture of half ISO VG 68 oil and half molybdenum disulfide lubricant compound (e.g. STP®).

Motor Assembly

Refer to Dwg. MHP1214 on page 20.

1. Apply a coating of Loctite® #609 Retaining Compound (as directed by Loctite® instructions) to the reverse valve bushing (26) and the valve chest bore. Support the face of the valve chest that contacts the valve chest cover. Align the keyslot in the reverse valve bushing with the bushing key (8). Once the bushing has been installed allow the Loctite® to cure for 10 minutes. Full cure requires 24 hours.
2. Press the reverse valve bushing into the chest until the leading face of the bushing is flush with the supported face of the valve chest.
3. Apply a coating of Loctite® #609 Retaining Compound (as directed by Loctite® instructions) to the rotary valve bushing (25) and the valve chest bore. Align the keyslot in the rotary valve bushing (24) with its bushing key and press the rotary valve bushing into the valve chest until the bushing shoulder is flush with the supported face of the valve chest.
4. Insert the No. 23470 throttle valve stem reamer or a 0.505 inch (12.9 mm) hand reamer through the throttle valve chamber in the valve chest and ream the hole through the wall of the new reverse valve bushing.
5. Check the fit of the rotary valve in the rotary valve bushing. If the valve is tighter than a good running fit in the bushing, lap the valve using a fine grain lapping compound with an abrasive agent that breaks up rapidly. Remove all trace of the compound with kerosene after obtaining the correct fit.
6. Check the fit of the reverse valve in the new reverse valve bushing. If the fit is too tight, ream the bushing to 1.625 inches (41.275 mm) in diameter.

NOTICE

- **The reverse valve is chrome-plated. Do not lap.**
7. Rotate the reverse valve in the reverse valve bushing until the arrows on the two parts are aligned.
 8. Install the throttle valve ball (21), poppet throttle valve (19), spring (18) and cap (16).
 9. Install the throttle lever spring (34) and throttle control arm (36).
 10. Align the valve chest holes with those in the face of the motor case and squarely start the protruding end of the rotary valve bushing into the motor case. Place a hardwood block on the valve chest face and press or drive the bushing in until the valve chest contacts the motor case.
 11. Lubricate bushing (64) and slide onto crank end (52). Bushing knob should line up with notch in crank counterweight.
 12. Place crank pin sleeve (65), plain end first, onto the crank shaft over the bushing.
 13. Slip one retaining ring (62) onto the crank shaft over the crank pin sleeve.

NOTICE

- **The two sections of the crank are matched before final machining and the web of each section is stamped with an identification number. Only sections bearing identical numbers can be used together. If more than one crank is disassembled at one time, ensure that only matched parts are assembled together.**

14. Install the connecting rod rings (62) so that the internally beveled ends are toward the connecting rods (61). Position one flange from each of the four connecting rods (61) in a circle between the retaining ring and the crank pin sleeve.
15. Fit the second retaining ring (62) over the other connecting rod flanges.
16. Place the crank counterweight over the second retaining ring and tap in the pin (49) until it protrudes out the other side.
17. Tighten pinch bolt (54).
18. Press splined end bearing (67) on crank end.
19. Tap end bearing (51) into motor housing (47).
20. Insert crank assembly into motor housing and line up piston rods with holes. Draw out one rod so it protrudes through hole.
21. Lubricate cylinder sleeve (55). Using **Ingersoll-Rand** ring compressor D10-933, tap on piston wrist pin (58) until pin goes through hole in rod and knocks off ring compressor.
22. Repeat to install all four cylinders.

Gear Case Assembly

Refer to Dwg. MHP1214 on page 20.

1. Fit eccentric clutch (75), spacer (74) and bearing (76) into slot in gearhousing section of base (94).
2. Place outer bearing (89), spring (88) and inner bearing (87), clutch release collar (86) and motor shaft pinion (85) on motor shaft (84) in that order.
3. Insert this assembly - outer bearing first - into the hole in the middle of the gear case section of the base.
4. Anchor the intermediate gear shaft (114) to the motor case cover (81) using pin (114).
5. Insert the bearing spacer (119) into the smaller gear end of the intermediate gear (118). Press the bearing (116) in on top of the bearing spacer.
6. Place the gear packing (117) into the larger gear side of the intermediate gear and press in bearing (116).
7. Slide the assembled intermediate gear onto the intermediate gear shaft.
8. Position the motor case cover on the gear section of the base, so that the teeth on the intermediate gear and the motor shaft pinion mesh.
9. Secure the clutch jaw on the motor shaft using pin (83).
10. Pack the chamber with grease.

Wire Rope Drum Assembly

Refer to Dwg. MHP1214 on page 20.

1. Turn manual brake handle anticlockwise to loosen brake band or, apply air to release automatic brake.
2. Secure drum cover (109) on the spoked end of the drum with drum cover screws (107), washers (4) and grease fitting (14).
3. Slide assembled drum (104) onto shaft under brake band (101).

Load Test

Prior to initial use, all new, extensively repaired, or altered winches shall be load tested by or under the direction of a person trained in safety and operation of this winch, and a written report furnished confirming the rating of the winch. Test loads shall not be less than **100%** of the rated line pull at mid drum and should not exceed **125%** of the rated line pull at mid drum.

NOTICE

- **Testing to more than 125% of rated line pull may be required to comply with standards and regulations set forth in areas outside the USA.**

WINCH ASSEMBLY DRAWING

EU Model

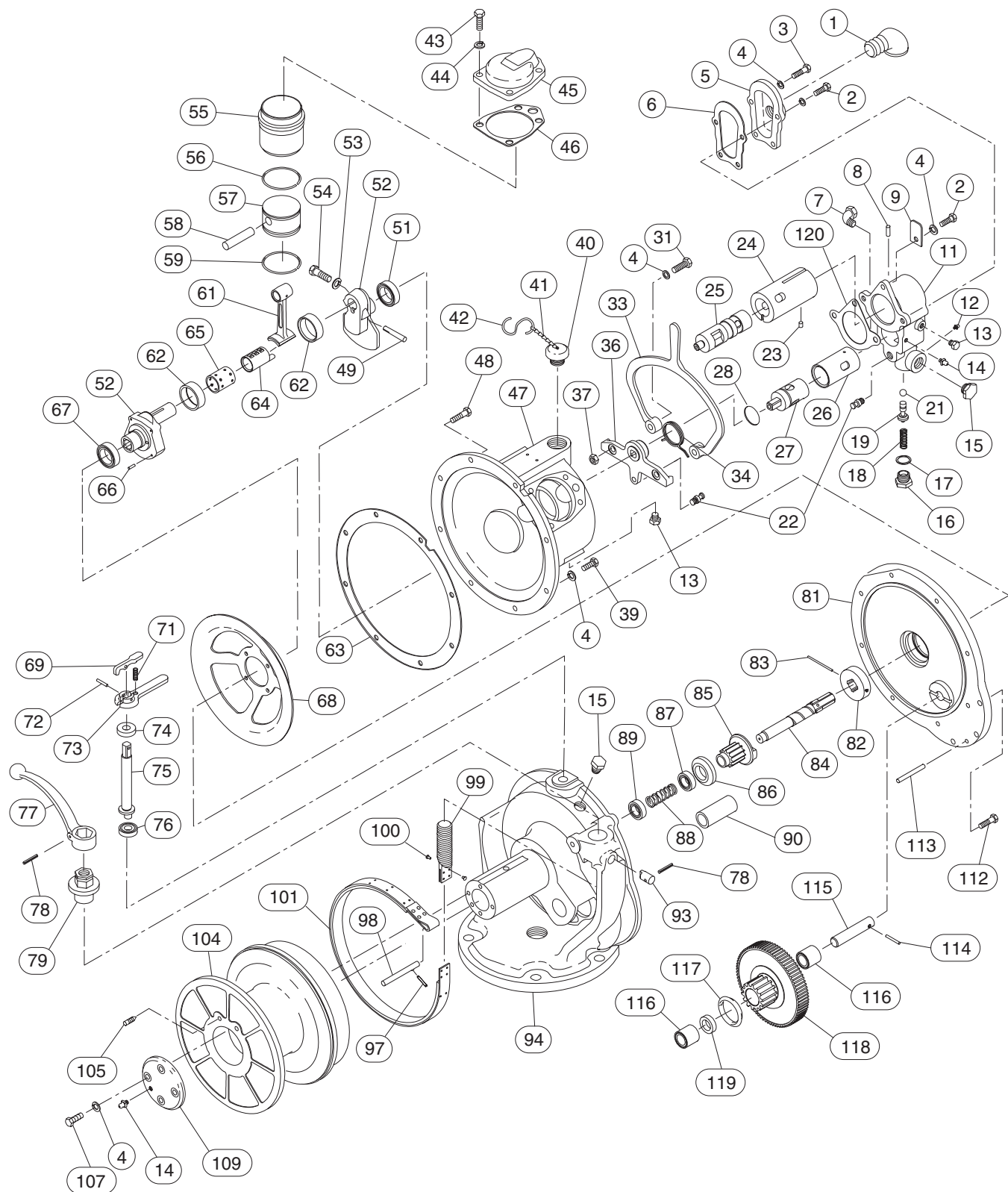

(Dwg. MHP1214)

WINCH ASSEMBLY PARTS LIST

Item No.	Description of Part	Total Qty	Part Number	
			Manual Brake	Automatic Brake
---	Motor Assembly (includes items 1-68)	1	EU-A501	
1	Exhaust Elbow	1	DU-587	
2	Capscrew (pack of 4)	1 pack	D02-506-4	
3	Capscrew	2	D10-548	
4	Lockwasher (pack of 10)	1 pack	D02-321-10	
5	Valve Chest Cover	1	D10-546A	
• 6	Gasket	1	D10-928	
7	Inlet Elbow	1	DU-581	
8	Valve Bushing Key	1	B12-255	
9	Throttle Lever Guide	1	DU-596	
11	Valve Chest	1	D10-545A	
12	Grease Fitting	1	R1-188	
13	Plug	()	51032 (4)	51032 (3)
14	Grease Fitting	2	53095	
15	Valve Chest Plug	2	22SR-165	
16	Throttle Valve Cap	1	D02-943	
17	Washer	1	G601-411	
18	Throttle Valve Spring	1	B01-11	
19	Poppet Throttle Valve	1	D02-940	
21	Throttle Valve Ball	1	D10-280	
22	Throttle Spring Stop Pin	2	D02-553	
23	Felt Plug	1	JA4-75	
24	Rotary Valve Bushing	1	D10-525AS	
25	Rotary Valve	1	D10-526	
26	Reverse Valve Bushing	1	D10-945-5S	
27	Reverse Valve	1	EU-944	D10-944
28	Reverse Valve Seal	1	---	PS3-42
31	Throttle Lever Bolt	2	D02-411A	
33	Throttle Lever	1	EU-556	
34	Throttle Lever Spring	1	D02-412B	
36	Throttle Control Arm	1	D10-555	
37	Nut	2	50205	
39	Capscrew	2	D10-312A	
40	Vent Cap Assembly (includes items 41-42C)	1	26604	
41	Vent Cap Chain	1	Order Item 40	
42	'S' Hook			
42A	Vent Cap Screen*			
42B	Vent Cap Screen Retainer*			
42C	Pin, Cotter*			
43	Cylinder Head Capscrew	16	D10-506	
44	Washer (Copper)	16	D10-504	
45	Cylinder Head	4	D10-H505A	
• 46	Cylinder Head Gasket	4	D10-507	
47	Motor Case	1	D10-501	
48	Capscrew	6	D10-312	
49	Pin, Taper	1	D10-520	

* Not Illustrated

() Models with Automatic Brake only

• Recommended spare for one winch, 2 years of normal operation.

WINCH ASSEMBLY PARTS LIST (CONT'D)

Item No.	Description of Part	Total Qty	Part Number	
			Manual Brake	Automatic Brake
51	Crank Valve End Bearing (includes item 65)	1	D04-956	
52	Crank	1	D10-K516	
52A	Crank Assembly (includes items 49, 51-54, 61, 62, 64, 66 and 68)	1	EU-A516	
53	Lockwasher	1	50181	
54	Capscrew	1	D10-521	
55	Cylinder Sleeve	4	D10-L505A	
56	Piston Ring	4	D10-KRING	
57	Piston Assembly (includes items 56 and 59)	4	D10-A513B	
58	Piston Wrist Pin	4	D10-514	
59	Oil Regulating Piston Ring	4	D10-KRING	
61	Connecting Rod	4	D10-509	
62	Retaining Ring	2	D10-510	
• 63	Gasket	1	D10-592	
64	Bushing	1	D10-511	
65	Crank Pin Sleeve	1	D10-519	
66	Rivet	4	D06-541	
67	Splined End Bearing	1	CE230-674	
68	Oil Splasher	1	D10-540	
69	Clutch Latch	1	DU-566	---
71	Spring	1	DU-567	---
72	Pin	1	DU-571	---
73	Clutch Lever	1	DU-565	---
74	Spacer	1	EU-599	---
75	Eccentric Clutch	1	DU-585A	---
76	Bearing	1	T03-33	---
77	Brake Lever	1	DU-570	---
78	Pin, Cotter	2	D02-438	---
79	Brake Adjusting Nut	1	DU-573	---
81	Motor Case Cover	1	EU-502	
82	Clutch Jaw	1	EU-568	
83	Pin	1	EU-569	
84	Motor Shaft	1	EU-316	
85	Motor Shaft Pinion (includes item 86)	1	EU-319	
86	Clutch Release Collar	1	Included with Item 85	---
87	Thrust Bearing	1	D01-379A	---
88	Spring	1	DU-583	---
89	Bearing	1	R4-24	
90	Clutch Jaw Spacer	1	---	DU-712
93	Brake Screw Guide	1	DU-594	
94	Winch Base (EU Model)	1	EU-564A	
	Winch Base (EUL Model)	1	EU-K564A	
97	Pin, Cotter	1	D02-330	
98	Brake Band Pin	1	---	DU-579
99	Brake Screw (includes item 100)	1	DU-K572	
100	Rivet	4	Included with item 99	

• Recommended spare for one winch, 2 years of normal operation.

WINCH ASSEMBLY PARTS LIST (CONT'D)

Item No.	Description of Part	Total Qty	Part Number	
			Manual Brake	Automatic Brake
101	Brake Band Assembly	1	DU-A574	DU-B574
104	Drum (EU Model)	1	EU-324	
	Drum (EUL Model)	1	EU-684	
105	Setscrew	2	DU-381	
107	Drum Cover Capscrew	4	51780	
109	Drum Cover	1	DU-580	
112	Motor Case Cover Screw	3	51597	
113	Dowel Pin	1	D02-347	
114	Intermediate Gear Shaft Pin	1	DU-368	
115	Intermediate Gear Shaft	1	DU-365	
116	Bearing	2	DU-366	
117	Intermediate Gear Packing	1	DU-600	
118	Intermediate Gear	1	EU-364	
119	Bearing Spacer	1	DU-593	
120	Gasket	1	D10-128	
123	Base, Outboard Support	1	EU-677	
124	Hub Bushing	1	EU-678	
125	Capscrew	2	52892	
126	Lockwasher	4	D01-692	
127	Capscrew	2	EU-775	
128	Locknut	2	DU-562	
•---	Brake Relining Kit (refer to MHD56142 for installation instructions)	1	DU-K575	

• Recommended spare for one winch, 2 years of normal operation.

EUL Model

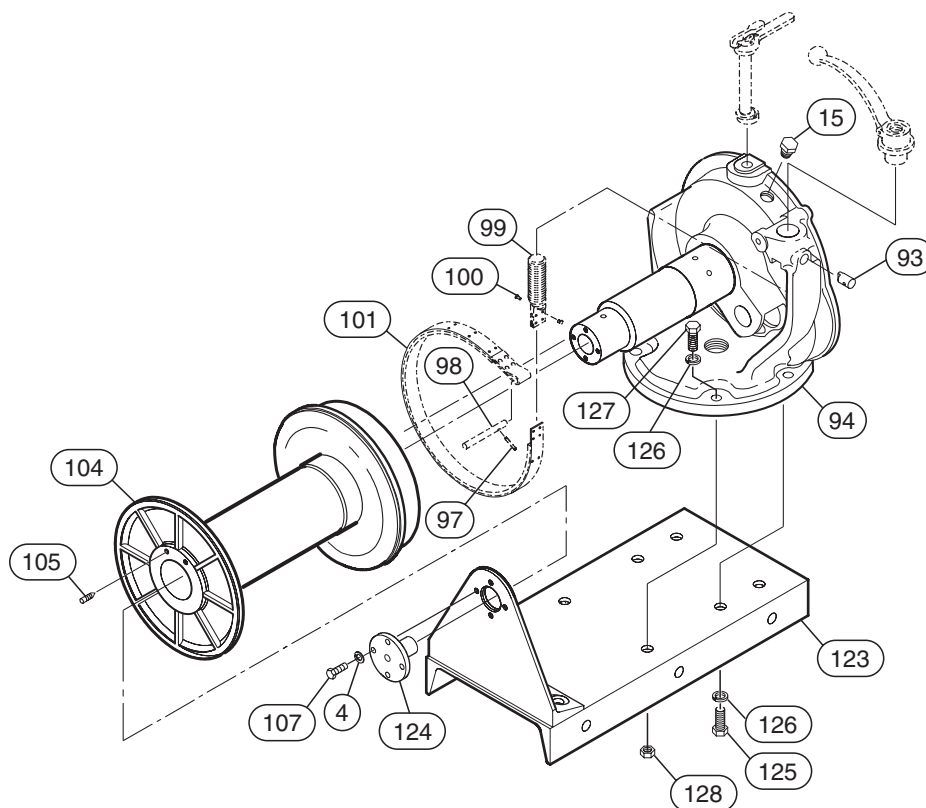

(Dwg. MHP2409)

AUTOMATIC BRAKE ASSEMBLY DRAWING AND PARTS LIST

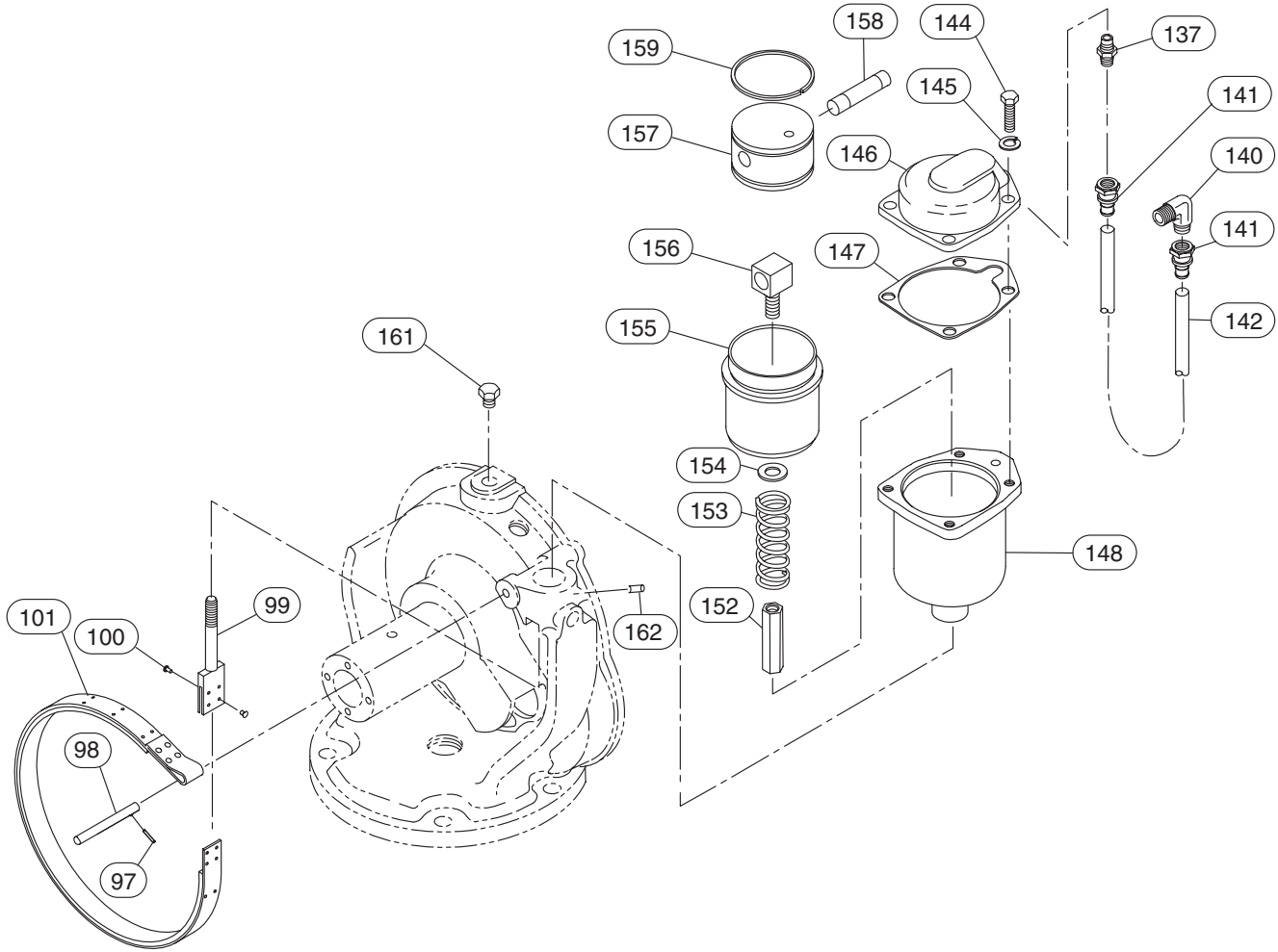

(Dwg. MHP1215)

Item No.	Description of Part	Total Qty	Part Number	Item No.	Description of Part	Total Qty	Part Number
97	Pin, Cotter	1	D02-330	• 147	Gasket	1	HU-507
98	Brake Band Pin	1	DU-579	148	Brake Cylinder Case	1	DU-709
99	Brake Screw (incl's item 100)	1	DU-K572	152	Brake Screw Coupling	1	DU-708
100	Rivet	4	Included with Item 99	153	Brake Spring	1	DU-710
101	Brake Band Assembly	1	DU-B574	154	Brake Spring Washer	1	DU-703
137	Fitting	1	53939	155	Cylinder Sleeve	1	HH5D-L505A
140	Fitting, Elbow	1	52182	156	Brake Trunnion	1	DU-702
141	Fitting, Swivel	2	51029	157	Piston (includes item 159)	1	DU-A713B
142	Hose (Bulk)	Specify Length	50923	158	Piston Wrist Pin	1	HU-514A
144	Capscrew	4	D10-354	159	Piston Ring	2	HU-337
145	Lockwasher (Copper)	4	HU-504	161	Plug	1	D02-351
146	Cylinder Head	1	HH5D-H505A	162	Setscrew	1	HU-867

• Recommended spare for one winch, 2 years of normal operation.

PENDANT ASSEMBLY DRAWING AND PARTS LIST

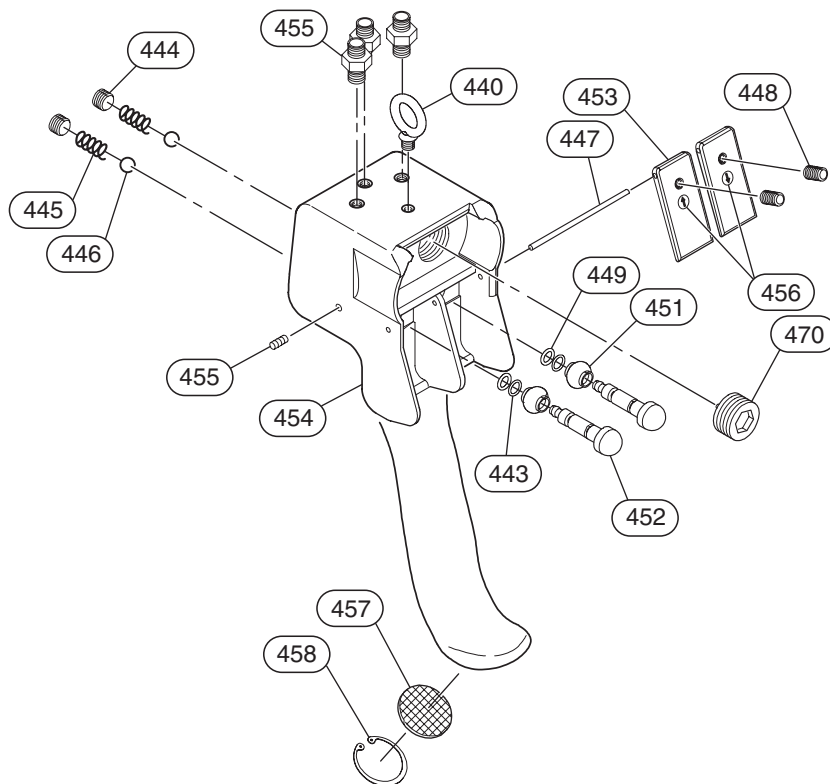

(Dwg. MHP2346)

Item No.	Description of Part	Total Qty	Part Number
353	Pendant Assembly*	1	PHS2E
440	Lifting Eye	1	64222332
• 443	'O' Ring	2(5)	58209229
444	Plug	2(4)	54292
445	Spring	2(4)	69128541
446	Ball	2(5)	69401625
447	Pin	1	95790040
448	Setscrew	2	42008607
• 449	'O' Ring	2(3)	58235329
451	Protector	2(3)	95790107
452	Valve	2(3)	95790104
453	Lever	2	95790122
454	Pendant Handle	1	order item 353
455	Setscrew	3(5)	71078158
456	Label Kit	1	95790111
457	Exhaust Washer	1	95790114
458	Retainer Ring	1	47713030
470	Plug	1	65129541

* Pendant Assembly includes items 440 to 449 and 451 to 458.

• Recommended spare for one winch, 2 years of normal operation.

DISCONTINUED PENDANT ASSEMBLY DRAWING

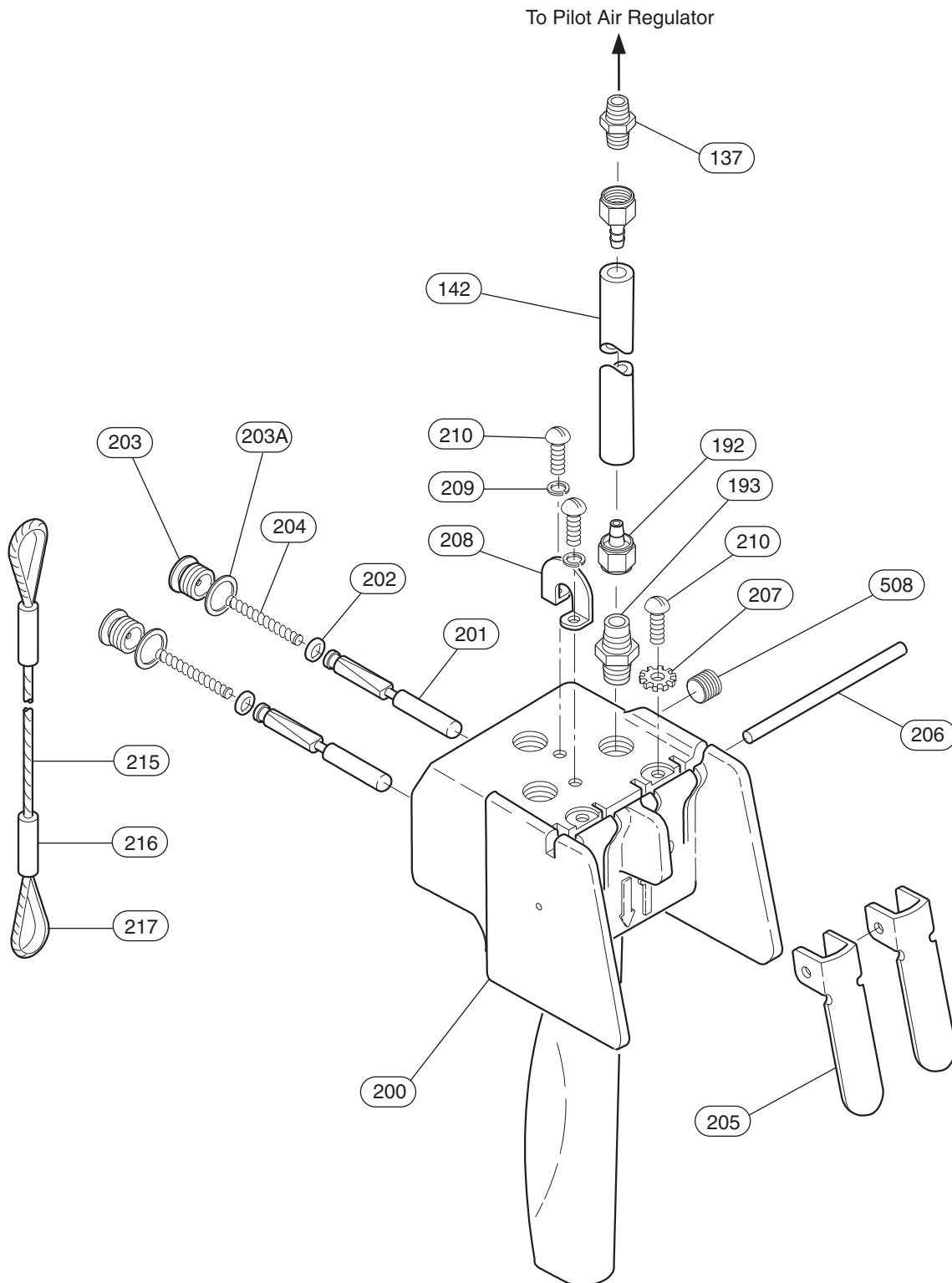

(Dwg. MHP1340)

DISCONTINUED PENDANT ASSEMBLY PARTS LIST

Item No.	Description of Part	Total Qty	Part Number
137	Fitting	3	53939
142	Hose (Bulk)	Specify Length	50923
200	Pendant Assembly (incl's items 200 through 210, 220)	1	MLK-A269C
201	Pendant Throttle Valve	2	MLK-K264B
• 202	Throttle Valve Face	2	R000BR1C-283
203	Pendant Throttle Valve Cap	2	MLK-K266A
203A	Valve Cap Gasket	2	MLK-239
• 204	Pendant Throttle Valve Spring	4	MLK-51A
205	Pendant Throttle Lever	2	MLK-273
206	Throttle Lever Pin	1	DLC-120A
207	Pin Lockwasher	2	D02-138
208	Strain Relief Support	1	MLK-450
209	Relief Support Lockwasher (pack of 10)	1 pack	H54U-352-10
210	Screw	4	HRE20-68
212	Fitting	6	51029
214	Fitting	6	71048268
---	Strain Relief Assembly (incl's items 215 through 217)	1	MLK-LWR3A
215	Strain Relief Cable	Specify Length	BWR3A
216	Clamping Sleeve	2	MLK-521
217	Clamping Thimble	2	MLK-602
221	Plug	1	54247
*	Hose Tie	As req'd	HRE20A-283

* Not Illustrated

• Recommended spare for one winch, 2 years of normal operation.

PILOT AIR VALVE ASSEMBLY PARTS LIST

Item No.	Description of Part	Total Qty	Part Number
1	Exhaust Elbow	1	DU-587
2	Capscrew (pack of 4)	1 pack	D02-506-4
4	Lockwasher (pack of 10)		D02-321-10
8	Valve Bushing Key	1	B12-255
137	Fitting, Adapter	5	53939
140	Fitting, Elbow	1	52182
141	Fitting, Swivel	8	51029
142	Bulk Hose, 2 ft to Brake and Control Valve (1 each req'd), 6.5 ft to Pendant (3 req'd)	Specify Length	50923
204	Valve Chest	1	C10-545
205	Valve Chest Cover	1	C10-546
501	Hose with Fittings	1	HU-925
506	Fitting, Tee	2	K6U-927
507	Regulator	2	K6U-200
508	Fitting, Connector	2	HHM-286A
509	Dump Valve	2	KU-939
514	Fitting, Connector	2	HHM-286
517	Fitting, Bushing	1	D01-705
518	Fitting, Elbow	1	54869
521	Fitting, Nipple	2	51034
522	Control Valve	1	UWB-802
525	Vented Plug	1	PAK-943
526	Valve	1	HU-264-4
528	Fitting, Tee	1	51812

REMOTE CONTROL ASSEMBLY DRAWING AND PARTS LIST

Remote Control Motor Components

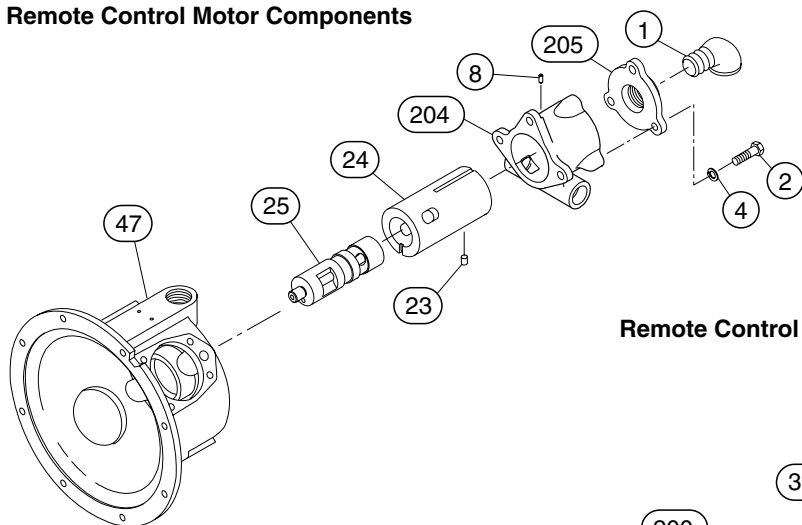

Remote Control Valve

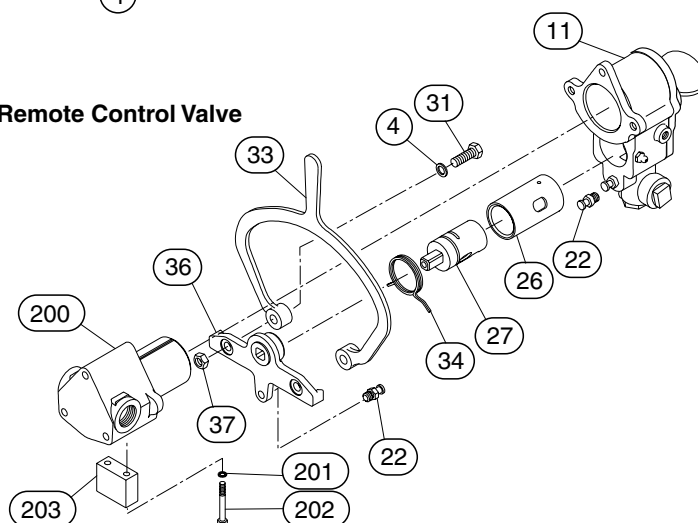

(Dwg. MHP1220)

Item No.	Description of Part	Total Qty	Part Number	
			Manual Brake	Automatic Brake
1	Exhaust Elbow	1	DU-587	
2	Capscrew (pack of 4)	1 pack	D02-506-4	
4	Lockwasher (pack of 10)	1 pack	D02-321-10	
8	Valve Bushing Key	1	B12-255	
11	Valve Chest	1	D10-545A	
22	Throttle Spring Stop Pin	2	D02-553	
23	Felt Plug	1	JA4-75	
24	Rotary Valve Bushing	1	D10-525AS	
25	Rotary Valve	1	D10-526	
26	Reverse Valve Bushing	1	D10-945-5S	
27	Reverse Valve	1	EU-944	D10-944
28	Reverse Valve Seal	1	---	PS3-42
31	Throttle Lever Bolt	2	D02-411A	
• 33	Throttle Lever	1	EU-556	
34	Throttle Lever Spring	1	D02-412B	
36	Throttle Control Arm	1	D10-555	
37	Nut	2	50205	
47	Motor Case	1	D10-501	
120	Gasket	1	D10-128	
200	Remote Control Block	1	D10-685	
201	Lockwasher (pack of 5)	1 Pack	T11-58-5	
202	Capscrew	2	54303	
203	Control Arm Retainer	1	D02-687	
204	Valve Chest	1	C10-545	
205	Valve Chest Cover	1	C10-546	

• Recommended spare for one winch, 2 years of normal operation.

LABELS AND TAGS ASSEMBLY DRAWING AND PARTS LIST

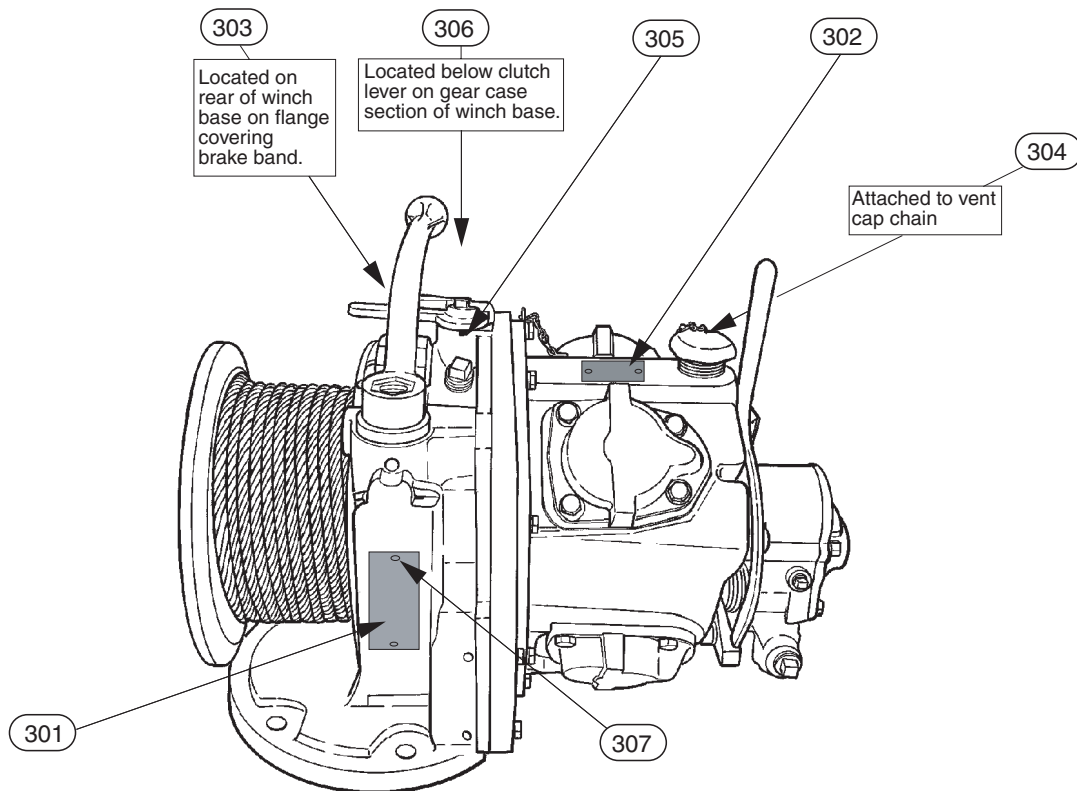

(Dwg. MHP1379)

Item No.	Description of Part	Total Qty	Part Number	
			Manual Brake	Automatic Brake
301	Winch Nameplate	1	71067003-R	
	Winch Nameplate-E	1	71373823-R	
302	Caution Plate - "Do Not Lift or Lower People"	1	MTK-147	
303	Warning Plate - "Do Not Weld Base"	1	TA-WELD	
304	Warning Tag - General	1	71056410	
305	Instruction Plate - Clutch "Engage-Disengage"	1	EU-94	---
306	Instruction Plate - "Apply Rope to Lift Winding this Direction"	1	DU-32	
307	Screw	15	R4K-302	

KITS, SPECIAL TOOLS AND ACCESSORIES

Description	Part Number
Piston Ring Compressor to compress Piston Rings (56) on Cylinder (57)	D10-933
Brake Adjusting Wrench	R55R-26
Jack Bolt	D02-932
Throttle Valve Stem Reamer	23470
Touch-up Paint (Yellow) 12 oz Spray Can	FAP-237Y
Wire Rope Lubricant 13 oz Spray Can	LUBRI-LINK-GREEN®
Drum Guard Kit (EU Model)	EU-K298A
Drum Guard Kit (EUL Model)	EUL-K298A
Auto Brake Kit (EU and EUL)	EU-C709
Air Strainer (3/4 inch)	EU-A267
Lubricator (3/4 inch)	L30-06-000
Filter (3/4 inch)	F30-06-000
Exhaust Muffler	50592

PARTS ORDERING INFORMATION

Use of other than **Ingersoll-Rand** replacement parts may adversely affect the safe operation and performance of this product.

For your convenience and future reference it is recommended that the following information be recorded.

Model Number _____

Serial Number _____

Date Purchased _____

When ordering replacement parts, please specify the following:

1. Complete model number and serial number as it appears on the nameplate.
2. Part number(s) and part description as shown in this manual.
3. Quantity required.

The nameplate is located on the winch outboard upright.

NOTICE

- **Continuing improvement and advancement of design may cause changes to this equipment which are not included in this manual. Manuals are periodically revised to incorporate changes. Always check the manual edition number on the front cover for the latest issue.**
- **Sections of this manual may not apply to your winch.**
- **Using other than genuine Ingersoll-Rand parts may void the warranty.**

Return Goods Policy

Ingersoll-Rand will not accept any returned goods for warranty or service work unless prior arrangements have been made and written authorization has been provided from the location where the goods were purchased.

Winches which have been modified without **Ingersoll-Rand** approval, mishandled or overloaded will not be repaired or replaced under warranty. A printed copy of the warranty which applies to this winch is provided inside the back cover of this manual.

Disposal

When the life of the unit has expired, it is recommended that it be disassembled, degreased and parts separated as to materials so that they may be recycled.

For additional information contact:

Ingersoll-Rand

P.O. Box 24046
2724 Sixth Avenue South
Seattle, WA 98124-0046 USA
Phone: (206) 624-0466
Fax: (206) 624-6265

or

Ingersoll-Rand

Douai Operations
111, Avenue Roger Salengro
59450 Sin Le Noble, France
Phone: (33) 3-27-93-08-08
Fax: (33) 3-27-93-08-00

SERVICE NOTES

LIMITED WARRANTY

Ingersoll-Rand Company (I-R) warrants to the original user its Hoists and Winches (Products) to be free of defects in material and workmanship for a period of one year from the date of purchase. **I-R** will repair, without cost, any Product found to be defective, including parts and labor charges, or at its option, will replace such Products or refund the purchase price less a reasonable allowance for depreciation, in exchange for the Product. Repairs or replacements are warranted for the remainder of the original warranty period.

If any Product proves defective within its original one year warranty period, it should be returned to any Authorized Hoist and Winch Service Distributor, transportation prepaid with proof of purchase or warranty card.

This warranty does not apply to Products which **I-R** has determined to have been misused or abused, improperly maintained by the user, or where the malfunction or defect can be attributed to the use of non-genuine **I-R** parts.

I-R makes no other warranty, and all implied warranties including any warranty of merchantability or fitness for a particular purpose are limited to the duration of the expressed warranty period as set forth above. I-R's maximum liability is limited to the purchase price of the Product and in no event shall I-R be liable for any consequential, indirect, incidental, or special damages of any nature rising from the sale or use of the Product, whether based on contract, tort, or otherwise.

Note: Some states do not allow limitations on incidental or consequential damages or how long an implied warranty lasts so that the above limitations may not apply to you.

This warranty gives you specific legal rights and you may also have other rights which may vary from state to state.

IMPORTANT NOTICE

It is our policy to promote safe delivery of all orders.

This shipment has been thoroughly checked, packed and inspected before leaving our plant and receipt for it in good condition has been received from the carrier. Any loss or damage which occurs to this shipment while en route is not due to any action or conduct of the manufacturer.

Visible Loss or Damage

If any of the goods called for on the bill of lading or express receipt are damaged or the quantity is short, do not accept them until the freight or express agent makes an appropriate notation on your freight bill or express receipt.

Concealed Loss or Damage

When a shipment has been delivered to you in apparent good condition, but upon opening the crate or container, loss or damage has taken place while in transit, notify the carrier's agent immediately.

Damage Claims

You must file claims for damage with the carrier. It is the transportation company's responsibility to reimburse you for repair or replacement of goods damaged in shipment. Claims for loss or damage in shipment must not be deducted from the **Ingersoll-Rand** invoice, nor should payment of **Ingersoll-Rand** invoice be withheld awaiting adjustment of such claims as the carrier guarantees safe delivery.

You may return products damaged in shipment to us for repair, which services will be for your account and form your basis for claim against the carrier.

United States Office Locations

For Order Entry and Order Status

Ingersoll-Rand Global Logistics

P.O. Box 618
510 Hester Drive
White House, TN 37188
Phone: (615) 474-8665
Fax: (615) 672-0854

Technical Support

Ingersoll-Rand

P.O. Box 24046
2724 Sixth Avenue South
Seattle, WA 98124-0046 USA
Phone: (866) 273-FAST(3278)
Fax: (206) 624-6265

Web Site:

www.airwinch.com

Regional Sales Offices

Annandale, NJ

P.O. Box 970
1467 Route 31 South
Annandale, NJ 08801
Phone: (908) 238-7000
Fax: (908) 238-7048

Detroit, MI

1872 Enterprise Drive
Rochester, MI 48309
Phone: (248) 293-5700
Fax: (248) 293-5800

International Office Locations

Offices and distributors in principal cities throughout the world. Contact the nearest **Ingersoll-Rand** office for the name and address of the distributor in your country or write/fax to:

Canada

National Sales Office

Regional Warehouse

Toronto, Ontario

51 Worcester Road
Rexdale, Ontario
M9W 4K2
Phone: (416) 213-4500
Fax: (416) 213-4510

Order Desk

Fax: (416) 213-4506

Latin America Operations

Ingersoll-Rand

730 N.W. 107 Avenue
Suite 300, Miami, FL, USA
33172-3107
Phone: (305) 559-0500
Fax: (305) 222-0864

Europe, Middle East and Africa

Ingersoll-Rand

Douai Operations

111, avenue Roger Salengro
59450 Sin Le Noble, France
Phone: (33) 3-27-93-08-08
Fax: (33) 3-27-93-08-00

Asia Pacific Operations

Ingersoll-Rand

Asia Pacific Ltd.

42 Benoi Road
Jurong, Singapore
629903
Phone: 65-861-1555
Fax: 65-861-1373

Russia

Ingersoll-Rand

Kuznetsky Most 21/5
Entrance 3
Moscow 103895 Russia
Phone: 7-501-923-91-34
Fax: 7-501-924-46-25

Australia

Ingersoll-Rand Aust

1 Hartnett Drive
Seaford, Vic 3198
Australia
Phone: 61 3 95541642
Fax: 61 3 95541607