

IMPORTANT INFORMATION:

- A copy of our “Safe Operating Practices” Manuals are always available free of charge either by downloading it from our Technical Publications website @ www.airwinch.com or by contacting the Factory at (800) 866-5457 for North America and (206) 624-0466 for International. The Safe Operating Practices manual must be read prior to anyone operating a **Ingersoll-Rand** winch or hoist. The manual form numbers are as follows:

“Safe Operating Practices Non-Man Rider™ Winches” Manual, Form No. MHD56250

“Safe Operating Practices for Man Rider™ Winches” Manual, Form No. MHD56251

“Safe Operating Practices for Pneumatic, Hydraulic and Electric Hoists” Manual, Form No. MHD56295

- Available winch options may require additional supplements to the basic winch manual.
- For Man Rider™ winches ensure a copy of the Man Rider™ supplement is made available to the operator prior to winch operation.

Winch Man Rider™ Supplements:

| Model: | Publication No. |
|---------------------------|--------------------------|
| FA2, FA2.5, FH2, FH2.5 | MHD56046 |
| FA5 | MHD56042 and MHD56220 |
| FA10 | MHD56252 |
| FA2.5A | MHD56236 |
| FA2B and HU40A | MHD56207 |
| FH10MR | MHD56212 |
| Fulcrum Electric | MHD56277 |
| LS500HLP/ LS1000HLP | SAM0004 |

| Model: | Publication No. |
|-----------------------------|-----------------|
| LS500RLP | SAM0011 |
| LS1000RLP | SAM0012 |
| LS150RLP | SAM0082 |
| LS150RLP/500/ 1000 | SAM0115 |
| LS150RLP and LS150PLP-PH | SAM0120 |
| LS500RLP-E | SAM0122 |
| LS150RLP- DP5M-F | SAM0184 |
| LS150HLP | SAM0222 |

- We strongly recommend that ALL maintenance on **Ingersoll-Rand** equipment be carried out by personnel certified by **Ingersoll-Rand**, or by **Ingersoll-Rand** Authorized Service Centers.
- Contact the Factory if in doubt about installation, operation, inspection and maintenance instructions.
- Use only Genuine **Ingersoll-Rand** parts when maintaining or repairing a winch, hoist or any component of a winch or hoist.
- ANSI / ASME recommends that a winch or hoist (or any components of a winch or hoist) that has been repaired be tested prior to being placed into service:
 - * **Winches** - ANSI / ASME B30.7 (BASE MOUNTED DRUM HOISTS) Refer to section 7.2.2 - Testing.
 - * **Hoists** - ANSI / ASME B30.16 (OVERHEAD HOISTS - UNDERHUNG) Refer to section 16.2.2 - Testing.

PARTS, OPERATION AND MAINTENANCE MANUAL

force **5**TM **AIR WINCHES**

MODEL

FA2.5MRA MANRIDER* WINCH

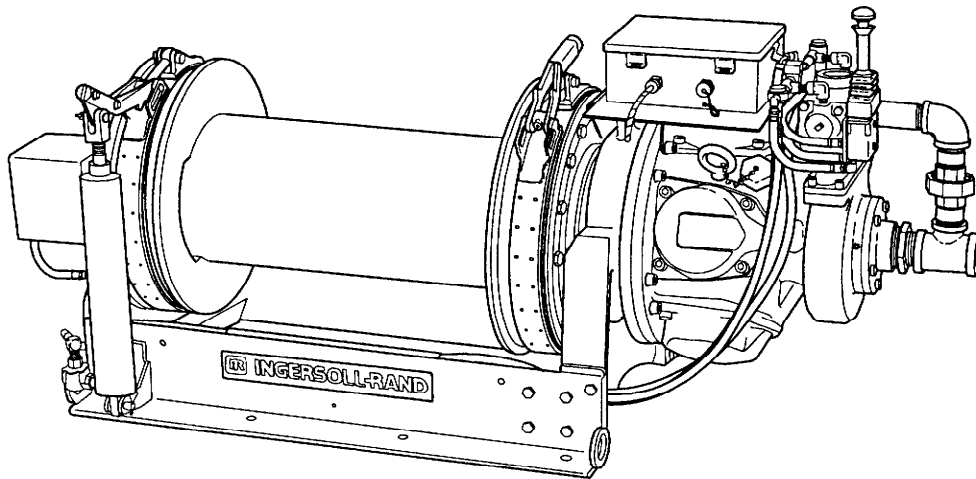

* Instructions contained in this manual apply only to winches designed by Ingersoll-Rand, and that are identified for personnel lifting by a permanent nameplate attached to the winch at the factory.

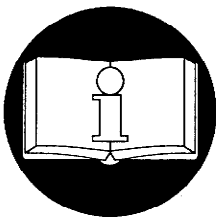

READ THIS MANUAL BEFORE USING THESE PRODUCTS. This manual contains important safety, installation, operation and maintenance information. Make this manual available to all persons responsible for the operation, installation and maintenance of these products.

The winch is only part of the Personnel Lifting System. For information defining the Personnel Lifting System requirements read ANSI A10.22 and all associated manufacturers' component literature. A copy of ANSI A10.22-1990 is provided with this product.

Always operate, inspect and maintain this winch in accordance with American National Standards Institute Safety Codes (ANSI A10.22 and ASME B30.7) and all other applicable local, state and federal safety codes and regulations.

TABLE OF CONTENTS

Safety Information

| | |
|---|---|
| Danger, Warning, Caution and Notice | 3 |
| Safety Summary | 3 |
| Winch Safe Operating Instructions | 4 |
| Winch Warning Labels | 5 |

Winch Specifications

| | |
|------------------------------------|---|
| General Specifications Chart | 5 |
| Model Code Chart | 6 |

Winch Installation

| | |
|------------------------------------|----|
| Mounting | 7 |
| Wire Rope | 8 |
| Rigging | 9 |
| Safe Installation Procedures | 9 |
| Air System | 9 |
| Motor | 10 |
| Electrical Grounding | 10 |
| Wire Rope Line Speed Monitor | 10 |
| Motor Exhaust and Muffler | 10 |
| Initial Operating Checks | 10 |

Winch Operation

| | |
|---|----|
| Personnel Lifting System | 11 |
| Initial Winch Operating Checks | 11 |
| Winch Component Operation | 12 |
| Winch Emergency Descent Procedure | 12 |
| Training | 13 |

Winch Lubrication

| | |
|-------------------------------------|----|
| Recommended Lubricants | 13 |
| Motor | 13 |
| Wire Rope | 14 |
| Reduction Gear Assembly | 14 |
| Disc Brake (optional feature) | 14 |
| Seals and Bearings | 14 |
| Air Line Lubricator | 14 |

Winch Inspection

| | |
|--------------------------------------|----|
| Records and Reports | 15 |
| Wire Rope Reports | 15 |
| System Inspections and Tests | 15 |
| Winch Inspections | 15 |
| Winches Not in Regular Service | 17 |

Winch Troubleshooting

| | |
|------------------------------------|---------|
| Winch Troubleshooting Charts | 19 - 20 |
|------------------------------------|---------|

Winch Maintenance

| | |
|---|----|
| Winch Adjustments | 21 |
| Disassembly | 23 |
| Cleaning, Inspection and Repair | 25 |
| Winch Assembly | 25 |
| Winch Testing | 28 |
| Winch Assembly Drawings and Parts Lists Table of Contents | 29 |

Parts Ordering Information

| | |
|---------------------------|----|
| Return Goods Policy | 46 |
| Warranty | 47 |

SAFETY INFORMATION

This manual provides important information for all personnel involved with the safe installation, operation and proper maintenance of this product. Even if you feel you are familiar with this or similar equipment, you should read this manual before operating the product.

Danger, Warning, Caution and Notice

Throughout this manual there are steps and procedures which, if not followed, may result in an injury. The following signal words are used to identify the level of potential hazard.

DANGER

Danger is used to indicate the presence of a hazard which will cause severe injury, death, or substantial property damage if the warning is ignored.

WARNING

Warning is used to indicate the presence of a hazard which can cause severe injury, death, or substantial property damage if the warning is ignored.

CAUTION

Caution is used to indicate the presence of a hazard which will or can cause injury or property damage if the warning is ignored.

NOTICE

Notice is used to notify people of installation, operation, or maintenance information which is important but not hazard-related.

Safety Summary

WARNING

- This winch was designed to meet ANSI A10.22-1990 which limits its use as part of a system for personnel lifting. There are other components required to complete the system. It is the users responsibility to supply all other components necessary to properly complete the lifting system in accordance with the regulations that pertain to the lifting application.
- It is the owner's and user's responsibility to check and to conform to all regulations (local, state, federal and country) that may apply to the use of a winch or winch system for lifting and lowering people before using a Man-Rider® winch for personnel movement.
- The supporting structures and load-attaching devices used in conjunction with this winch must provide an adequate safety factor to handle the rated load, plus the weight of the winch and attached equipment. This is the customer's responsibility. If in doubt, consult a registered structural engineer.

Ingersoll-Rand Man-Rider® winches are designed and manufactured to meet or exceed standards and specifications established for base mounted drum hoists as defined by ASME B30.7 and for the purpose of personnel handling as defined by ANSI A10.22 - 1990.

In furnishing customers **Man-Rider®** winches, **Ingersoll-Rand** does not warrant the suitability of these winches for any particular use. It is the owner's and user's responsibility to determine the suitability of this winch for a particular application.

Ingersoll-Rand Man-Rider® winches manufactured to ANSI A10.22 standards are designed as a component in the Personnel Lifting System. **Ingersoll-Rand** approval for use of this winch in **Man-Rider®** applications automatically terminates for any of the following reasons:

1. Winch is not installed in an approved personnel lifting system.
2. Winch is not properly maintained in a safe working condition, with all parts intact and properly adjusted.
3. Winch is used in applications not approved by codes and regulations, or application is inconsistent with manufacturer's operation and maintenance manual.
4. More than one winch is used to attach to a common load.
5. Winch design or functions are altered or changed in any manner from the purchased original without prior approval by **Ingersoll-Rand**.

This manual has been produced by **Ingersoll-Rand** to provide company personnel, dealers, mechanics and operators with the information required to install, operate, and maintain the products described herein.

It is extremely important that mechanics and operators be familiar with the servicing procedures of these products, or like or similar products, and are physically capable of conducting the procedures. These personnel shall have a general working knowledge that includes:

1. Proper and safe use and application of common mechanics' hand tools as well as special **Ingersoll-Rand** or recommended tools.
2. Safety procedures, precautions and work habits established by accepted industry standards.

Ingersoll-Rand can not know of, nor provide all the procedures by which product operations or repairs may be conducted and the hazards and/or results of each method. If operation or maintenance procedures not specifically recommended by the manufacturer are conducted, it must be ensured that product safety is not endangered by the actions taken. If unsure of an operation or maintenance procedure or step, personnel should place the winch in a safe condition and contact supervisors and/or the factory for technical assistance.

WINCH SAFE OPERATING INSTRUCTIONS

The following warnings and operating instructions have been adapted in part from American National (Safety) Standards ASME B30.7 and ANSI A10.22, and are intended to avoid unsafe operating practices which might lead to injury or property damage.

Ingersoll-Rand recognizes that most companies who use winches have a safety program in force at their facility. In the event that a conflict exists between a rule set forth in this publication and a similar rule already set by an individual company, the more stringent of the two should take precedence.

WARNING

• **Failure to follow these operating instructions may result in death or property damage. Ingersoll-Rand assumes no liability for any loss or damage resulting from operation of Man-Rider® winches if these operating instructions are not followed.**

Safe Operating Instructions are provided to make an operator aware of dangerous practices to avoid and are not necessarily limited to the following list. Refer to specific sections in the manual for additional safety information.

1. Winch operator must be in vocal contact with personnel being lifted (lowered) from transfer point to landing area.
2. Personnel supervising, operating the winch and personnel being transferred are to be instructed in system operation and safety prior to personnel lifting. Only operate a winch if you are physically fit to do so.
3. Use of a winch to transport personnel (lifting and/or lowering) should only take place when other means of accomplishing this work are not practical.
4. When a “**DO NOT OPERATE**” sign is placed on the winch, or winch controls, do not operate the winch until the sign has been removed by designated personnel.
5. Never lift a load greater than the rated capacity of the winch. Refer to “**SPECIFICATIONS**” section for applicable utility and **ManRider®** capacity ratings.
6. Prior to use, inspect and test the personnel lifting system to the requirements of ANSI A10.22 Section 13 (Inspection and Tests). The winch operator shall be instructed in the operation of this winch and the personnel lifting system per ANSI A10.22 Section 5 (Operation of Hoist).
Winch only: Refer to ‘Testing’ procedures in the “**WINCH INSPECTION**” section of this manual for winch information.
7. Installation of the winch must be specially arranged and approved for personnel handling as a component in a Personal Handling System as described and defined in ANSI A10.22. Refer to the “**INSTALLATION**” section. All bolts and foundations for winch attachment must have a higher load carrying capacity rating than the maximum capacity of the winch.
8. Do not operate a damaged winch.
9. Do not operate a winch that has not been properly maintained or equipped.
10. Do not operate winch with any personnel near the line of force or capable of coming into contact with moving parts.
11. Labels and warning notices must remain permanently posted, and be clearly visible on the winch.
12. Ease the slack out of the wire rope when starting a lift. Do not jerk the load.
13. Never leave a suspended load unattended.
14. Wire rope must spool off drum from the top away from the operator (overwind). The direction of lift is counterclockwise when viewed from the motor end of the winch.
15. Make sure the wire rope is properly anchored to the winch drum.
16. Pay attention to the load at all times when operating the winch.
17. Never use the winch wire rope as a sling.
18. Do not leave a load suspended when winch is not in use.
19. Ensure muffler is positioned at the point furthest away from winch operator.
20. Do not use limit switch settings to regulate the winch stopping points. Limit switches are designed as a backup to operator accidental over travel only.
21. Ensure the end of the wire rope is weighted to prevent line run.

WINCH WARNING LABELS

Each unit is shipped from the factory with the warning label shown. If the label is not attached to your unit, order a new label and install. See the parts list for the part number. Label is shown smaller than actual size.

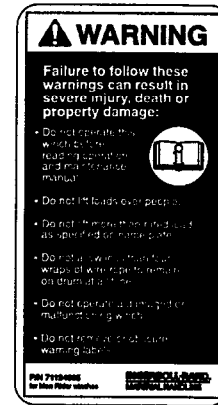

WINCH SPECIFICATIONS

| General Specifications | | Model FA2.5MRA | | | |
|---|--|--------------------|-------------|-------------------------|-------------|
| | | Utility Rating * | | ANSI ManRider® Rating * | |
| Air System | Rated Operating Pressure | 90 psig (6.2 bar) | | | |
| | Consumption Volume (at rated pressure) | 700 scfm | 20 cu.m/min | 700 scfm | 20 cu.m/min |
| Performance (at rated pressure / volume) | Rated Full Drum Line Pull * | 3,520 lbs | 1,600 kgs | 2,200 lbs | 1,000 kgs |
| | Line Speed - 3rd Layer (UP) | 108 fpm | 33 m/min | 130 fpm ** | 40 m/min ** |
| | Line Speed - 3rd Layer (DOWN) | 148 fpm | 45 m/min | 136 fpm ** | 42 m/min ** |
| | Max Stall Pull - 1st Layer | 10,000 lbs | 4,536 kgs | 10,000 lbs | 4,536 kgs |
| | FA2.5MRA Net Weight | 1136 lbs | 516 kgs | 1136 lbs | 516 kgs |
| Air Motor Pipe Inlet Size | | 1-1/4 inch | 32 mm | 1-1/4 inch | 32 mm |
| Minimum Air System Hose Size | | 1-1/2 inch | 38 mm | 1-1/2 inch | 38 mm |
| Drum Wire Rope Storage Capacity *** (feet / metres) | Drum Length (inches) | Wire Rope Diameter | | | |
| | | 7/16 inch | | 12 mm | |
| | 8 | 269 feet | 82 metres | | |
| | 12 | 404 feet | 123 metres | | |
| | 16 | 539 feet | 164 metres | | |
| | 24 | 808 feet | 246 metres | | |
| 30 | 1010 feet | 308 metres | | | |

* FA2.5 Utility rating of 3,500 lbs. (1,558 kg) is based on requirements of ASME B30.7 (5:1 design factor with 7/16 inch (11 mm) wire rope.)

FA2.5 ManRider® rating of 2,200 lbs. (1,000 kg) is based on requirements of ANSI A10.22 (24:1 drum to wire rope ratio) and factory recommended 8:1 safety design factor of 8:1 using 7/16 inch (11 mm) wire rope.)

** Line speed ratings for Personnel Lifting describe the design capabilities of the winch. Operators must limit winch speed to a maximum of 100 feet per minute (30.5 metres per minute) when using the winch as a personnel lifting device to comply to ANSI A10.22.

*** FA2.5 ManRider® wire rope storage is based on a winch with a 19 inch (483 mm) diameter drum flange and on ANSI A10.22 standards which require the top layer to be at least 2 inches (51 mm) below the drum flange diameter. Capacities shown may vary from those published elsewhere.

Model Code Explanation

Example: FA2.5MRA24MA1G

FA2.5 MRA 24 M A 1 G

Series (Capacity):

Model FA2.5 Personnel Lifting - 1 metric ton / 2,200 lbs.

Utility Lifting - 1.6 metric tons / 3,500 lbs.

Designation:

MRA = Man Rider® ANSI A10.22-1990 *

Drum Length (Distance between drum flanges):

| | | | |
|----|---|---------|---------------------|
| 8 | = | 8 inch | (203 mm) |
| 12 | = | 12 inch | (305 mm) |
| 16 | = | 16 inch | (406 mm) |
| 24 | = | 24 inch | (610 mm) (Standard) |
| 30 | = | 30 inch | (762 mm) |

Brake:

M = Manual Drum Brake (Standard)

A = Automatic Drum Brake (Standard)

K = Automatic Disc Brake

Control:

1 = Winch mounted lever throttle (Standard)

3XX = Remote pilot pendant throttle with warning light (XX = Specify hose length (feet)) **

5XXX = Remote electric throttle control (XXX = Specify hose length (feet)) **

Options:

Z = Sand blast and Carbozinc primer only

P = Marine 812 top coat

G = Drum Guard

7 = Drum Grooving (Number = wire rope size in sixteenths, c.g. 7/16 inch)

- * Standard Features:
- (1)
 - (2) Line Speed Monitor.
 - (3) Adjustable upper and lower rotary limit switches.
 - (4) Piped away exhaust with muffler and 10 feet (3 metres) of exhaust hose.
Copy of Operation and Maintenance Manual and ANSI A10.22 Standard supplied in
 - (5) container attached to winch.
Manual and Automatic Drum Band Brake.

** Remote pendants are provided with standard length 10 feet (3 metres) hose. Specify hose lengths greater than 10 feet. For lengths greater than 50 ft. (15 metres) with the Remote Pilot Pendant Throttle or Remote Pilot Electric Throttles contact Technical Sales for control acceptability. Metric lengths for reference only, order lengths required to be in feet.

Note: FA2.5MRA winches are shipped with a muffler, 10 feet (3 m) of exhaust hose and the necessary assembly attachments to install the muffler at a distance far enough away from the operator to ensure noise level exposure of less than 90 dBA over an eight hour period (Time Weighted Average (TWA)). The recommended distance is based on noise levels recorded during factory testing. Refer to the "INSTALLATION" section for additional information.

WINCH INSTALLATION

Prior to installing the winch, carefully inspect it for possible shipping damage. Winches are supplied fully lubricated from the factory. Before operation check oil levels and adjust as necessary. Use the proper type of oil as recommended in the "LUBRICATION" section.

⚠ CAUTION

• Owners and users are advised to examine specific, local or other regulations, including ANSI A10.22, ASME B30.7 and/or OSHA Regulations which may apply to a particular type of use of this product before installing or putting winch to use.

Mounting

Care must be taken when moving, positioning or mounting the winch. In most cases, lifting lugs have been provided to assist in handling the winch. If the lug locations are improper for your specific installation, great care should be taken to ensure that the winch, when lifted, will be properly balanced. Determine the weight of your winch by referring to the "SPECIFICATIONS" section. Lift the winch 3 to 4 inches (75 to 100 mm) off the ground. Verify winch is balanced and secure before continuing lift.

⚠ CAUTION

• Care must be taken when lifting the winch. Determine winch center of gravity and arrange lifting straps to raise the winch evenly.

• If the winch is mounted to a portable foundation, always attach the lifting straps or cables to the foundation structure when lifting and supporting the winch assembly.

⚠ WARNING

• Install the wire rope to come off the drum for overwind operation **ONLY**. Failure to correctly spool the wire rope will result in falling load, which can cause severe injury, death and property damage. Refer to Dwg. MHTPA0661.

1. Ensure the winch is positioned in a manner that allows for proper spooling of the wire rope onto the drum. When installed correctly, the direction of lift is counterclockwise as viewed from the motor end of the winch (clockwise from outboard end of winch). Refer to Dwg. MHTPA0661.
2. Mount the winch so the axis of the drum is horizontal and that the motor vent cap is not more than 15° off top vertical center. If the winch is to be mounted in an inverted position, the motor case must be rotated to position the vent cap at the top.

3. The winch mounting surface must be flat and of sufficient strength to handle the rated load plus the weight of the winch and attached equipment. An inadequate foundation may cause distortion or twisting of the winch uprights and side rails resulting in winch damage.
 - a. Make sure the mounting surface is flat to within 1/16 inch (2.0 mm). Shim if necessary.

FA MRA Series Winch Wire Rope Take Off Diagram (Overwind Operation Only)

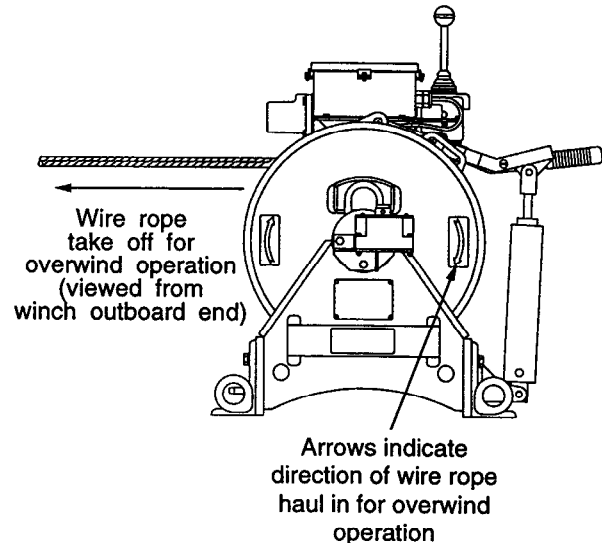

(Dwg. MHTPA0661)

4. Recommended mounting bolts: 5/8 inch (16 mm) Grade 8 or better. Use self-locking nuts or nuts with lockwashers. Refer to Dwg. MHTPA0133 and Table 1 for mounting dimension information. To determine clamping load tensile and shear strength requirements refer to Dwg. MHTPA0692 and Table 2.

Winch Bolt Hole Mounting Dimensions

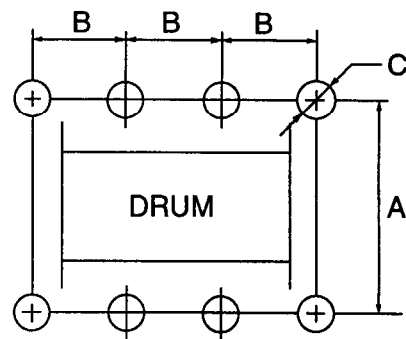

(Dwg. MHTPA0133)

Table 1: Bolt Hole Dimensions

| Dimension | | Drum Length (inches) | | | | |
|-----------|-----|----------------------|-----|-----|-----|------|
| | | 8* | 12* | 16 | 24 | 30 |
| "A" | in. | 20 | | | | |
| | mm | 508 | | | | |
| "B" | in. | 9 | 7.5 | 9 | 11 | 12.5 |
| | mm | 229 | 191 | 229 | 279 | 318 |
| "C" | in. | 0.687 | | | | |
| | mm | 17.5 | | | | |

* 3 Bolt holes per side rail.

FA2.5MRA Winch Foundation Bolt Forces

Calculated for 1st Layer stall load [9,680 lbf (2,176 N)]

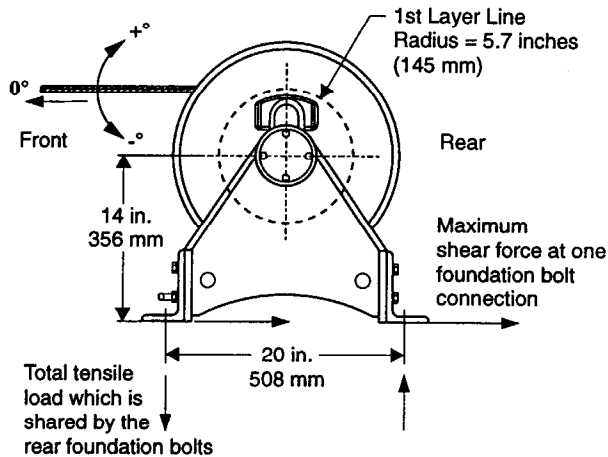

(Dwg. MHTPA0692)

Table 2: Winch Foundation Bolt Forces

| Force Acting on Bolt | | Drum Length (inches) | | | | |
|--|-----|----------------------|-------|-------|-------|----|
| | | 8 | 12 | 16 | 24 | 30 |
| Maximum Shear Force at One Foundation Bolt Connection * | lbf | 2,070 | 1,770 | 1,950 | 2,210 | |
| | N | 9,207 | 7,873 | 8,674 | 9,830 | |
| Maximum Tensile Force Shared by Rear Foundation Bolts ** | lbf | 11,080 | | | | |
| | N | 49,284 | | | | |

* Maximum shear force occurs when wire rope is at a 0° angle.

** Maximum tensile force occurs when wire rope is at a 36° angle.

- Use 5/8 inch (16 mm) Grade 8 mounting bolts. Tighten evenly and torque to 220 ft. lbs. (298 Nm) for dry thread fasteners. If the fasteners are plated, lubricated or a thread locking compound is used, torque to 170 ft. lbs. (230 Nm).
- Maintain a fleet angle between the sheave and winch of no more than 1-1/2°. The lead sheave must be on a center line with the drum and for every inch of drum length, be at least 1.6 feet (0.5 metre) from the drum. Refer to Dwg. MHTPA0498.
- Do not weld to any part of the winch.

Wire Rope



- Do not use wire rope which is less than 7/16 inch (11 mm) minimum nominal diameter.
- Maintain at least 4 tight wraps of wire rope on the drum at all times. Ensure wire rope top layer is a minimum of 2 inches (51 mm) below drum flange edge. Refer to Dwg. MHTPA0498.
- To prevent wire rope "line run" ensure a weight greater than the total weight of the longest 'wire rope pay out to sheave' length is attached to the end of the wire rope. 7/16 inch IWRC wire rope average weight per foot: 0.35 lbs/foot (0.52 kg/metre).

Wire Rope and Drum Diagram

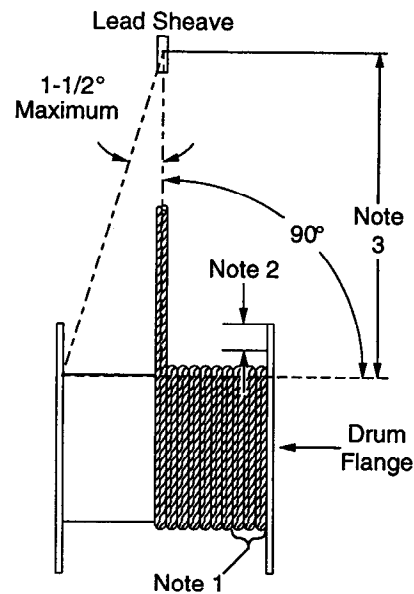

(Dwg. MHTPA0498)

Notes:

- Always maintain a minimum of 4 tight wraps of wire rope on the drum.
- The minimum allowed distance from top of wire rope layer to drum flange edge is 2 inches (51 mm).
- 1.6 feet (0.5 metre) per inch of drum length; eg., for 12 inch drum length locate lead sheave 19.2 feet (6 metres) from drum.

Wire Rope Selection

Consult a reputable wire rope manufacturer or distributor for assistance in selecting the appropriate type and size of wire rope and, where necessary, a protective coating. Use a wire rope which provides an adequate safety factor to handle the actual working load.

When considering wire rope requirements the actual working load must include not only the static or dead load but also loads resulting from acceleration, retardation and shock load. Consideration must also be given to the size of the winch wire rope drum, sheaves and method of reeving. Wire rope construction must be 6 X 19 or 6 X 37 IWRC right lay to permit correct installation of wire rope anchor. Refer to Table 3 for applicable wire rope sizes.

Table 3: Minimum and Maximum Wire Rope Size

| Model | Minimum | | Maximum | |
|-----------------|---------|----|---------|----|
| | inch | mm | inch | mm |
| FA2.5 Utility | 7/16 | 11 | 5/8 | 16 |
| FA2.5 ManRider* | 7/16 | 11 | 7/16 | 11 |

* 7/16 inch (11 mm) wire rope must be used on FA2.5MRA winches used for personnel lifting to conform to ANSI A10.22 standards.

NOTICE

• Use only 7/16 inch (12 mm) wire rope on the FA2.5MRA winch if used for personnel handling.

Installing Wire Rope

(Refer to Dwg. MHTPA0166)

1. Cut wire rope to length in accordance with the wire rope manufacturer's instructions.
2. Feed the end of the wire rope into the wire rope anchor hole in the drum and pull through approximately one foot (305 mm) of wire rope.

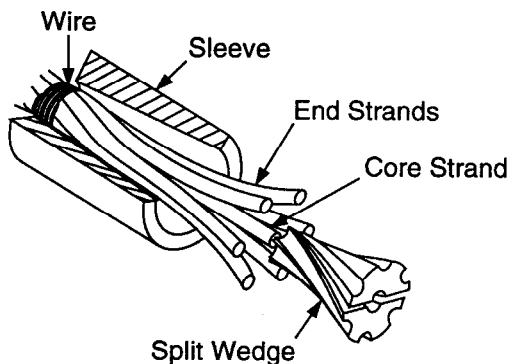

(Dwg. MHTPA0166)

3. Wrap the wire rope with wire a distance from the end equal to the wedge length plus one inch (25 mm).
4. Slide the sleeve over the end of the wire rope so the larger diameter of the taper bore is nearest the end of the wire rope.
5. Spread the end strands of the wire rope and insert the split wedge until it is below the end of the wire rope.
6. Pull the sleeve over the wire rope end until tight. Check that the wire rope strands stay in the slots located on the split wedge.
7. Pull the wire rope anchor into position in the drum anchor pocket.

CAUTION

• Make sure the first wrap of wire rope is tight and lays flush against the drum flange. Also ensure that each succeeding wrap is tight against the previous one.

Safe Wire Rope Handling Procedures

1. Always use gloves when handling wire rope.
2. Never use wire rope which is frayed or kinked.
3. Never use wire rope as a sling.
4. Always ensure wire rope is correctly spooled and the first layer is tight against the drum.

Wire Rope Spooling

To compensate for uneven spooling and the decrease in line pull capacity as the drum fills up, use as short a wire rope as practical. When rewinding apply tension to the end of the wire rope to eliminate line slack. This helps achieve level winding and tight spooling.

NOTICE

• Wire rope must be spooled at least 2 inches (51 mm) below the outer diameter of the drum flange. Refer to Dwg. MHTPA0498.

Rigging

Make sure all wire rope blocks, tackle and fasteners have a sufficient safety margin to handle the required load under all conditions. Do not allow wire rope to contact sharp edges or make sharp bends which will cause damage to wire rope, use a sheave. Refer to the wire rope manufacturer's handbook for proper sizing, use and care of wire rope.

Safe Installation Procedures

1. Do not use wire rope as a ground (earth) for welding.
2. Do not attach a welding electrode to winch or wire rope.
3. Never run the wire rope over a sharp edge. Use a correctly sized sheave.
4. When a lead sheave is used, it must be aligned with the center of the drum. The diameter of the lead sheave must be at least 24 times the diameter of the wire rope. Refer to Dwg. MHTPA0498.
5. Always maintain at least four full, tight wraps of wire rope on the drum.

Air Supply

The air supply must be clean and free from moisture.

Air Lines

The inside diameter of the winch air supply lines must not be less than the sizes shown in Table 4. Before making final connections, all air supply lines should be purged with clean, moisture free air or nitrogen before connecting to winch inlet. Supply lines should be as short and straight as installation conditions will permit. Long transmission lines and excessive use of fittings, elbows, tees, globe valves etc. cause a reduction in pressure due to restrictions and surface friction in the lines.

Table 4: Minimum Allowable Air Supply Line Sizes

| Model | inch | mm |
|----------|-------|----|
| FA2.5MRA | 1-1/2 | 38 |

Air Line Lubricator

(Refer to Dwg. MHTPA0191)

Always use an air line lubricator with these motors. The lubricator must have an inlet and outlet at least as large as the inlet on the motor. Install the air line lubricator as close to the air inlet on the motor as possible.

⚠ CAUTION

- Lubricator must be located no more than 10 ft. (3 m) from the motor.

The air line lubricator should be replenished daily and set to provide 6 to 9 drops per minute of SAE 10W oil. A fine mist will be exhausted from the throttle control valve when the air line lubricator is functioning properly.

Air Line Filter

(Refer to Dwg. MHTPA0191)

It is recommended that an air line strainer/filter be installed as close as practical to the motor air inlet port, but before the lubricator, to prevent dirt from entering the motor. The strainer/filter should provide 20 micron filtration and include a moisture trap. Clean the strainer/filter periodically to maintain its operating efficiency.

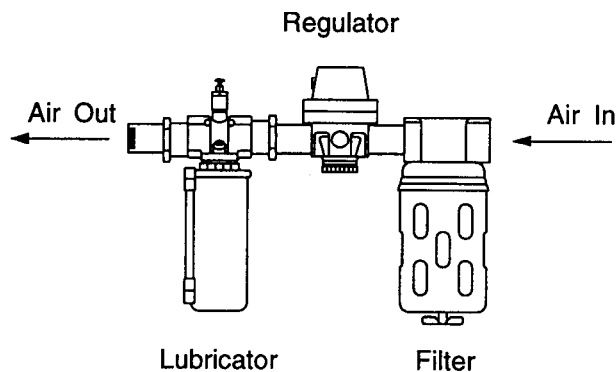

(Dwg. MHTPA0191)

Moisture in Air Lines

Moisture that reaches the air motor through air supply lines is a primary factor in determining the length of time between service overhauls. Moisture traps can help to eliminate moisture. Other methods, such as an air receiver which collects moisture before it reaches the motor, an aftercooler at the compressor that cools the air to condense and collect moisture prior to distribution through the supply lines are also helpful.

Motor

For optimum performance and maximum durability of parts, provide an air supply of 90 psig at 700 scfm (6.2 bar/620 kpa at 20 cu.m/m) for FA2.5MRA winches. The air motor should be installed as near as possible to the compressor or air receiver. Recommended pressures and volumes are measured at the point of entry to the air motor.

Electrical Grounding

⚠ WARNING

- The Personnel Lifting System must be properly grounded to conform to ANSI A10.22 standards. Ensure electrical grounding is conducted by licensed electricians in accordance with the latest edition of the National Electric Code (ANSI/NFPA 70) and any applicable local, state and national electric codes and ordinances.

An electrical grounding lug is attached to the winch siderail. Place ground wire into the lug and secure in place with the setscrew. Attach other end of wire as required to establish an electrical ground. Ensure winch is correctly grounded to the Personnel Lifting System before using winch.

Wire Rope Line Speed Monitor

Winches are equipped with a battery powered line speed monitor and overspeed indicator. Ensure the indicator sensor is adjusted as described in the "WINCH ADJUSTMENTS" section.

The line speed monitor rechargeable battery will operate for twenty-five eight hour days at 33% actual on time (winch operation time). An amber light indicates the battery requires recharging. Approximately one day of operation remains when the recharge light indication comes on. Refer to the "MAINTENANCE" section for recharging procedures.

Motor Exhaust and Muffler

(Refer to Dwg. MHTPA0646)

⚠ WARNING

- Operator exposure to noise levels shall not exceed 90 dBA over an 8 hour period (Time Weighted Average (TWA)). Ensure motor and pilot valve air is properly exhausted and muffled.

Winch noise level ratings under factory test conditions:

1. 83 dBA during operation of winch without load in the haul in direction.
2. 87 dBA during operation of winch without load in the pay out direction.

These levels were achieved when the motor and pilot valve air was exhausted through a 10 foot (3 metre) length of hose and attached to a muffler.

Initial Operating Checks

Winches are tested for proper operation prior to leaving the factory. Before the winch is placed into service the following initial operating checks should be performed.

1. When first running the motor inject some light oil into the inlet connection to provide initial lubrication.
2. When first operating the winch it is recommended that the motor be driven slowly in both directions for a few minutes.

For winches that have been in storage for a period of more than one month the following start-up procedure is required.

1. Give the winch an inspection conforming to the requirements of "Winches Not in Regular Use" in the "INSPECTION" section.
2. Pour a small amount of 10W oil in the motor inlet port.
3. Operate the motor for 10 seconds in both directions to flush out any impurities.
4. The winch is now ready for normal use.

WINCH OPERATION

The four most important aspects of winch operation are:

1. Follow all safety instructions when operating the winch.
2. Allow only people trained in safety and operation of this winch to operate this equipment.
3. Subject each winch to a regular inspection and maintenance procedure.
4. Be aware of the winch capacity and weight of load at all times.

WARNING

- Operate this winch **ONLY** if wire rope is installed to come off the drum for overwind operation. Refer to Dwg. MHTPA0564.
- Operation of this winch in a safe manner, as part of a Personnel Lifting System, requires that supervisors, operators, and personnel being transported be thoroughly instructed in the potential dangers involved and the safety procedures established to minimize the risks of accident, injury and property damage.
- Do not transport personnel and materials at the same time. Safe operation, according to established standards, require that personnel and materials are to be transported separately.
- Visual inspections of the winch and entire Personnel Lifting System must be conducted by designated personnel instructed in safety, operation and maintenance of this product before using the winch to transport personnel. Any visual indication of damage must be inspected, repaired and actions documented in accordance with component manufacturers' instructions to ensure the safety of personnel is not compromised.

Personnel Lifting System

Owners are responsible for establishing, implementing and ensuring that supervisors, operators, and personnel being transported are instructed in operation and safety procedures. Refer to 'Training' in the "WINCH OPERATION" section.

1. Supervisors, operators and personnel being lifted should check that winch, wire rope, working platform, lifelines, safety belts (harnesses), etc. are present and functional prior to authorizing personnel lifting.
2. Personnel being transported must be instructed in and adhere to the safety procedures established including, but not limited to, the following list:

- a. Emergency Escape Procedures in accordance with ANSI A10.22 Section 11.
- b. Use of safety belts (harnesses) and rope grabs (lifelines) in accordance with ANSI A10.22 Sections 11, 12.4 and 12.5.
3. Winch operators must be instructed in and adhere to the procedures established to ensure proper and safe operation of this winch as a component in a Personnel Lifting System.
 - a. Winch operators must remain at the winch controls at all times when handling personnel and materials.
 - b. At any indication of winch, or system, damage or impending danger the winch operator must place the winch in a safe condition and notify designated personnel. Winch and system operation must be suspended until all discrepancies noted have been inspected, repaired and system tested to ensure safe operation.
 - c. Voice communication must be established and maintained between winch operator, personnel being lifted and personnel located at each landing (as applicable).
 - d. Winch operators must maintain at least 4 tight wraps of wire rope on the drum at all times.
 - e. Wire rope shall be weighted on the end to prevent line run when spooling onto the drum.

Initial Winch Operating Checks

NOTICE

- Initial operating checks specific to the entire Personnel Lifting System should be established to ensure system component compatibility.

Winches are tested for proper operation of all features prior to shipping. Before the winch is placed into service the following initial operating checks should be performed.

1. When first running the motor inject a small amount of oil into the inlet connection to provide initial and immediate lubrication.
2. When first operating the winch run the motor slowly in both directions for a few minutes.
3. Verify both drum brakes function as described in 'Winch Testing' in the "WINCH INSPECTION" section. To adjust the brakes refer to 'Winch Adjustments' in the "WINCH MAINTENANCE" section.

- Adjust and verify limit switch settings. To adjust the limit switch set points refer to 'Winch Adjustments' in the "WINCH MAINTENANCE" section.
- Verify line speed monitor and overspeed alarm operation as described in 'Winch Testing' in the "WINCH INSPECTION" section.
- Verify automatic drum brake emergency release system operation as described in 'Winch Testing' in the "WINCH INSPECTION" section.

Winch Component Operation

Pilot Air Throttle Control Lever

(Refer to Dwg. MHTPA0608)

Winch control lever directions are described as viewed when facing the winch motor and apply to overwind operation only. To ensure smooth operation of the winch sudden movements of the control valve should be avoided.

- To payout wire rope, lift up on the winch control lever and move the lever to the right.
- To haul in wire rope, lift up on the winch control lever and move the winch control lever to the left.

Pilot Air Throttle Control Operation

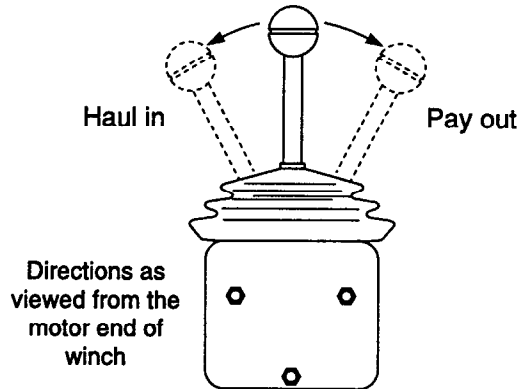

(Dwg. MHTPA0608)

Manual Drum Brake

The manual drum brake may be applied by pushing down on the brake handle and released by pulling up. If the handle is pushed down fully, it should lock in that position and prevent drum rotation, until released by the operator. The brake must be kept properly adjusted to hold the required load. To adjust the brake refer to 'Winch Adjustments' in the "WINCH MAINTENANCE" section.

Automatic Drum Brake

The automatic drum brake is a spring applied, air released brake. Using an air actuated, spring loaded cylinder the brake automatically disengages when the motor is operated. Air pressure in the cylinder overcomes spring pressure to release the brake. When the pilot air throttle control lever is placed in the neutral position, the air in the cylinder is vented and the spring automatically engages the brake to prevent drum rotation.

The cylinder clevis must be kept properly adjusted to hold the required load. To adjust the brake refer to 'Winch Adjustments' in the "WINCH MAINTENANCE" section.

Limit Switch

Pre-set limit switch settings prevent winch wire rope payout and haul in by stopping air flow to the winch motor when a set point has been reached. It is the owner's and operator's responsibility to adjust winch operating limits prior to using the winch to transport personnel. To adjust the limit switch set points refer to 'Winch Adjustments' in the "WINCH MAINTENANCE" section.



- Ensure limit switch operates properly and that limits have been set before using winch to transport personnel.

Line Speed Monitor and Overspeed Alarm

The Line Speed Monitor is a battery powered wire rope line speed indicator system which determines line speed by sensing drum rotation.

The Line Speed Monitor provides a visual alarm (flashing red light) and digital readout (in feet) to allow the operator to adjust throttle control to maintain wire rope line speed at 100 feet per minute (30.5 metres per minute) or less. Line Speed Monitors are factory pre-set to match the winch installed on and cannot be adjusted. The overspeed indicator light flashes when drum speed exceeds wire rope line speeds of 100 feet per minute (+/- 10 feet) (30.5 metres per minute; +/- 3 metres) in either direction of drum rotation.

Winch Emergency Descent Procedure

(Refer to Dwgs. MHTPA0669 and MHTPB0636)



- ANSI A10.22-1990 Section 11 defines the Personnel Lifting System requirements for establishing emergency escape methods and procedures. The following procedure describing the use of the winch to lower personnel or loads when the supply air to the winch has been interrupted should only be used after all other established methods have been exhausted.

The lowering speed of the load using the winch descent procedure is dependent upon the weight of the load, amount of cable on the drum, and position of the load in the lifting system.

To use the winch to lower the load when the air supply has been interrupted conduct the following:

- Engage the manual band brake.
- Depress the automatic band brake clevis (107) and remove cotter pin (102) and pin (106) to disconnect cylinder (110) from brake lever (105).
- Slowly disengage manual band brake using the brake lever (104). Regulate speed of load using manual band brake. If load does not lower engage band brake and then conduct the following step.
- Remove capscrews (364) from motor adapter valve (468) and remove pilot valve/adapter assembly from winch motor.

- Use the manual band brake to throttle lowering speed (if required) when lowering the load.

Training

Prior to using the Personnel Lifting System supervisors, operators, service personnel, and personnel being transported must be thoroughly instructed in the potential dangers involved and the safety procedures established to minimize the risks of accident, injury and property damage.

Establishment of safe operating procedures for the Personnel Lifting System should be based on ANSI A10.22 specifications, OSHA regulations, all applicable local, state and national standards, system component manufacturers's recommendations, and system designer recommendations.

Records of training should be maintained and made available to designated personnel for review.

WINCH LUBRICATION

To ensure continued satisfactory operation of the winch, all points requiring lubrication must be serviced with the correct lubricant at the proper time interval as indicated for each assembly.

The lubrication intervals recommended in this manual are based on intermittent operation of the winch eight hours each day, five days per week. If the winch is operated almost continuously or more than the eight hours each day, more frequent lubrication will be required. Also, the lubricant types and change intervals are based on operation in an environment relatively free of dust, moisture, and corrosive fumes. Use only those lubricants recommended. Other lubricants may affect the performance of the winch. Approval for the use of other lubricants must be obtained from your **Ingersoll-Rand** distributor. Failure to observe this precaution may result in damage to the winch and/or its associated components.

| INTERVAL | LUBRICATION CHECKS |
|---------------------|--|
| Start of each shift | Check flow and level of air line lubricator (approximately 6 to 9 drops per minute required at maximum motor speed). |
| | Check winch motor oil level. |
| Monthly | Lubricate components supplied by grease fittings. |
| | Inspect and clean or replace air line filter. |
| | Check reduction gear oil level. |
| Yearly | Drain and refill winch reduction gear oil. |
| | Drain and refill winch motor oil. |

Note: Intervals are based on winch operation in a normal environment as described in the "INSPECTION" section. In 'Heavy' or 'Severe' operating conditions adjust lubrication intervals accordingly.

Recommended Lubricants

Oil

| Temperature | Type Oil |
|-------------------------------|----------|
| 1. Below 32° F (0° C) | SAE 10W |
| 2. 32° to 80° F (0° to 27° C) | SAE 20W |
| 3. Above 80° F (27° C) | SAE 30W |

Grease

| Temperature | Type Grease |
|-------------------------------------|---|
| 1. -20° to 50° F (-30° to 10° C) | EP 1 multipurpose lithium-based grease |
| 2. 30° to 120° F (-1° to 49° C) | EP 2 multipurpose lithium-based grease |

Motor

(Refer to Dwg. MHTPA0758)

Correct lubrication is one of the most important factors in maintaining efficient winch operation. The motor is splash lubricated by the oil in the motor housing and has no other means of lubrication. It is therefore important to use only quality, non-detergent motor oil to ensure maximum performance and minimum downtime for repairs. Refer to the 'Recommended Lubricants' section. Allow oil to settle before topping off.

Oil capacity for the **FA2.5MRA** winch motor is 3 quarts (2.8 litres). Add oil through the fill plug opening until oil flows from the level plug hole. Add oil slowly to prevent spilling.

The motor should be level-checked daily or at the start of each shift after accumulated water has been drained off. When motors are operated in temperatures below freezing, wait long enough at end of shift for water to separate from oil but not long enough for it to freeze. Drain the water then refill to the level plug. If desired, all the oil may be drained at the end of the shift and the motor refilled with new oil.

Motor Lubrication Locations

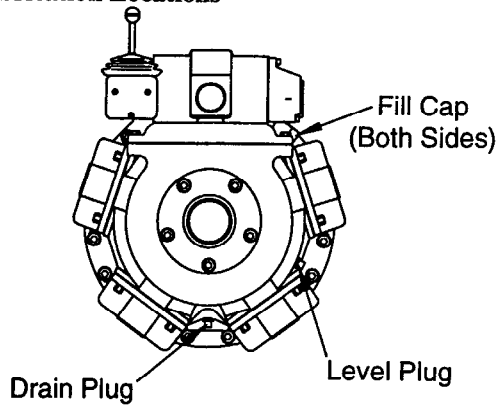

(Dwg. MHTPA0758)

Wire Rope

Follow the wire rope manufacturer's instructions. At a minimum, observe the following guidelines.

1. Clean with a brush or steam to remove dirt, rock dust or other foreign material on the surface of the wire rope.



- Do not use an acid-based solvent. Only use cleaning fluids and lubricants specified by the wire rope manufacturer.

2. Apply a wire rope lubricant, **Ingersoll-Rand LUBRI-LINK-GREEN** or SAE 30W oil.
3. Brush, drip or spray lubricant weekly, or more frequently, depending on severity of service.

Reduction Gear Assembly

(Refer to Dwg. MHTPA0140)

The reduction gear assembly is filled and shipped with oil from the factory. Check oil level before initial winch operation. If the winch is used at a normal frequency replace the oil in the reduction housing once every year. To ensure correct performance, highest efficiency and long life, it is essential that the lubricating oil be maintained at the correct level. Rotate the drum until the fill plug is located at top dead center then add oil up to the level plug hole. Oil capacity for the reduction gear assembly is 1-1/2 quarts (1.4 litres).



- Do not over fill. Excess oil will reduce operating efficiency and increase oil temperature.

The recommended grade of oil must be used at all times since the use of unsuitable oil may result in excessive temperature rise, loss of efficiency and possible damage to the gears. Refer to the 'Recommended Lubricants' section. Use only high quality lubricants in the reduction gear assembly such as motor oil, high grade EP type hydraulic oil or their equivalents.

Reduction Gear Lubrication Plug Locations

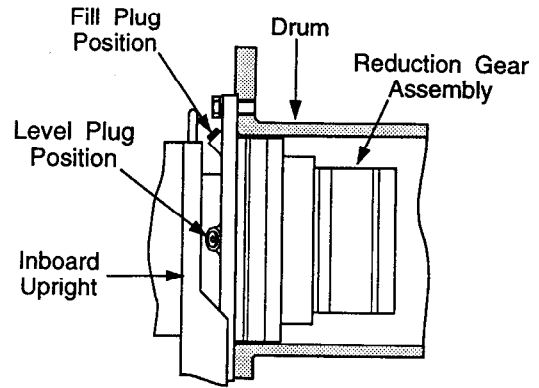

(Dwg. MHTPA0140)

Drum Brakes

Lubricate pivot points, pins and shafts with recommended grease to prevent corrosion of parts.



- Do not allow grease or oil to come into contact with drum band brake linings.

Disc Brake (optional feature)

Oil from the reduction gear assembly also provides lubrication for the disc brake. After an oil change or winch overhaul remove the breather plug and pour 6 to 8 fluid ounces (0.2 litres) through the breather hole in the brake housing to initially lubricate the brake discs. Refer to the 'Recommended Lubricants' section. Reinstall the breather plug before operation of winch or brakes.

Seals and Bearings

If winch is disassembled, clean all parts thoroughly and coat bearings and seals with clean grease. Refer to the 'Recommended Lubricants' section. Use sufficient grease to provide a good protective coat. Lubricate grease fittings monthly with 2 or 3 pumps of a grease gun.

Air Line Lubricator

Replenish lubricator **daily** and set to provide 6 to 9 drops of oil per minute. Refer to the 'Recommended Lubricants' section for recommended oil.

Wire Rope Line Speed Monitor

Does not require lubrication.

Limit Switch

Does not require lubrication.

Inspection information is based in part on American National Standards Institute Safety Codes (A10.22 and B30.7).

Records and Reports

Personnel Lifting System

Owners are responsible for establishing and implementing operation and safety procedure training for all personnel involved in the use and operation of a Personnel Lifting System.

1. **PERSONNEL TRAINING.** Records of training provided to supervisors, operators, service personnel and personnel being transported should be maintained and made available to designated personnel for review.
2. **SYSTEM MAINTENANCE.** Records of all service, maintenance and testing performed on the Personnel Lifting System should be maintained and made available to designated personnel for review.

Winch Records and Reports

Inspection records, listing all points requiring inspection, should be maintained for all load bearing equipment. Written reports, based on **Initial, Weekly and Quarterly** inspections, should be made on the condition of critical parts as a method of documenting inspections. These reports should be dated, signed by the person who supervised the performance of the inspection, and kept on file where they are readily available for review. A sample winch 'Inspection and Maintenance Report' has been provided at the end of this section.

Wire Rope Reports

Records should be maintained as part of a long-range wire rope inspection program. Records should include the condition of wire rope removed from service. Accurate records will establish a relationship between visual observations noted during frequent inspections and the actual condition of wire rope as determined by periodic inspections.

Personnel Lifting System wire rope records should be maintained and made available to designated personnel for review.

System Inspections and Tests

WARNING

• **Information provided by Ingersoll-Rand is applicable only to the winch to assist in determining the condition of the winch components described. References to other Personnel Lifting System components are made with respect to their relationship to the winch. For specific information on system components other than the winch, reference the manufacturers' literature and ANSI A10.22.**

Personnel Lifting System inspections and tests of installed components, functions and safety devices should be established based on procedures derived from ANSI A10.22 specifications, OSHA regulations, manufacturers' literature and recommendations, system designer recommendations and all applicable local, state and national standards.

1. **SYSTEM.** Frequency of inspections:
 - a. Initial system inspection.
 - b. Daily checks and Weekly inspections.
 - c. Quarterly inspections.

System Initial and Quarterly Inspections

In addition to established Daily and Weekly inspections conduct the following:

NOTICE

• **The static drop test is only required for guided cage systems.**

1. **INITIAL INSPECTION.** With the cage at rated load, on a guided cage system, using dead weights, conduct a static drop test. This test is designed to ensure the cage safety clamps engage and stop the cage from falling. Perform requirements of the weekly inspection.
2. **QUARTERLY INSPECTION.** With the cage empty, on a guided cage system, conduct a static drop test. This test is designed to ensure the cage safety clamps engage and stop the cage from falling. Perform requirements of the weekly inspection.

System Testing

Personnel Lifting System testing should be conducted in accordance with the system specific instructional manual and component manufacturers' recommendations. A system specific instruction manual must be compiled to conform to the requirements of ANSI A10.22, and detail the operation, maintenance and safety requirements of the various components comprising the personnel lifting system.

Winch Inspections

The following listed inspections apply only to the winch. These inspections should be conducted when scheduled, when indicated by winch performance and when the winch is disassembled for repair.

Careful inspection on a regular basis will reveal potentially dangerous conditions while still in the early stages, allowing corrective action to be taken before the condition becomes dangerous.

Damage revealed through inspection, or noted during operation, must be reported to designated personnel instructed in safety, operation and maintenance of this equipment. A determination as to whether a condition constitutes a safety hazard must be made, and the correction of noted safety hazards accomplished and documented by written report before placing the equipment in service.

⚠ WARNING

- All new, altered or modified equipment should be inspected and tested by personnel instructed in safety, operation and maintenance of this equipment to ensure safe operation at rated specifications before placing equipment in service.
- Never use a winch that inspection indicates is damaged.
- Prior to using the winch to lift personnel, an initial inspection should be conducted after assembly, major repairs or alteration, and when the system has been idle for periods of longer than one month.

Daily checks, weekly and quarterly inspections should be performed on equipment in regular use.

1. **Daily checks** are visual examinations performed by operators or personnel instructed in safety and operation of this equipment and include observations made during routine equipment operation.
2. **Weekly inspections** are thorough inspections conducted by personnel instructed in safety, operation and maintenance of this equipment. Weekly inspections are also required prior to personnel lifting if the system has been idle for periods in excess of one week, but less than one month.
3. **Quarterly inspections** are a combination of weekly inspection requirements and the performance of a static drop test on **guided cage systems only** to verify operation of the cage's safety clamp.

Winch Daily Checks and Weekly Inspections

On equipment in continuous service, weekly inspections are required. Maintain written records of weekly inspections to provide an accumulative basis for continuing evaluation. Disassembly may be required as a result of inspection findings.

In addition, daily checks, or visual inspections should be conducted by operators during regular operation for damage or evidence of malfunction.

1. **WINCH (DAILY)**. At the beginning of the shift, prior to operation, visually inspect winch housings, controls, brakes, siderails and drum for indications of damage. Do not operate the winch until all discrepancies noted have been reviewed, inspected further and corrected by personnel instructed in the operation, safety and maintenance of this winch.
WINCH (WEEKLY). Inspect the following:
 - a. **SIDE RAILS AND END UPRIGHTS**. Check for deformed, cracked or corroded main components. Replace damaged parts.

- b. **FASTENERS**. Check retainer rings, split pins, capscrews, nuts, and other fasteners on winch, including mounting bolts. Replace if missing or damaged and tighten if loose.
 - c. **DRUM AND SHEAVES**. Check for cracks, wear or damage. Replace damaged parts.
2. **WIRE ROPE**. Visually inspect all wire rope which can be expected to be in use during the day's operations. Inspect for wear and damage indicated by distortion of wire rope such as kinking, "birdcaging," core protrusion, main strand displacement, corrosion, broken or cut strands. If damage is evident, do not operate winch until the discrepancies have been reviewed and inspected further by an experienced wire rope inspector.

NOTICE

- The full extent of wire rope wear cannot be determined by visual inspection. At any indication of wear inspect the wire rope in accordance with the following instructions.

In addition to daily check requirements, also inspect for the following weekly:

- a. Ensure wire rope is spooled onto the drum for overwind operation only and that a minimum of 2 inches (50 mm) clearance is maintained between the outside edge of the drum flange and the outermost layer of wire rope.
- b. Buildup of dirt and corrosion. Clean with steam or a stiff wire brush to remove dirt and corrosion if necessary.
- c. Loose, frayed or damaged end connection. Replace if loose, frayed or damaged. Ensure ends will not catch on personnel.
- d. Ensure the wire rope is securely anchored in the winch drum.
- e. Verify wire rope diameter. Measure the diameter of the wire rope from crown-to-crown throughout the life of the wire rope. Recording of the actual diameter should only be done with the wire rope under equivalent loading and in the same operating section as accomplished during previous inspections. If the actual diameter of the wire rope has decreased more than 1/64 inch (0.4 mm) a thorough examination of the wire rope should be conducted by an experienced inspector to determine the suitability of the wire rope to remain in service. (Refer to Dwg. MHTPA0056).

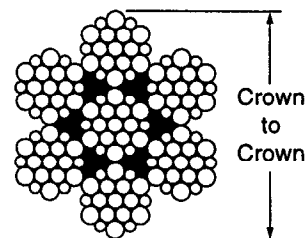

(Dwg. MHTPA0056)

3. **AIR SYSTEM (WEEKLY).** Visually inspect all connections, fittings, hoses and components for indication of air leaks. Repair any leaks and replace damaged components.
4. **CONTROLS (DAILY AND WEEKLY).** During operation of winch, verify response to control is quick and smooth. If winch responds slowly or movement is unsatisfactory, do not operate winch until all problems have been corrected.
5. **BRAKES (WEEKLY).** Ensure proper operation. Verify each brake system will hold a 150% rated load with full drum (as applicable to normal use) without slipping. If indicated by poor operation or visual damage, disassemble and repair brake(s). Check all brake surfaces for wear, deformation or foreign deposits. If drum brake lining thickness is 0.062 inch (2 mm) or less anywhere along its edge replace brake bands or linings. Clean and replace components as necessary. Test each brake system independently.
6. **LIMIT SWITCHES (WEEKLY).** Verify winch limit switches operate at the set limits. When actuated, limit switches interrupt air flow to the motor in the direction of winch operation only. Adjust limit settings or repair to correct all noted discrepancies.
7. **ALL COMPONENTS (WEEKLY).** Inspect for wear, damage, distortion, deformation and cleanliness. If external evidence indicates damage, disassemble as required to conduct a detailed inspection. Inspect gears, shafts, bearings, springs and covers. Replace worn or damaged parts. Clean, lubricate and reassemble.
8. **SUPPORTING STRUCTURE (WEEKLY).** Check for distortion, wear and continued ability to support winch. Ensure winch is firmly mounted and that fasteners are in good condition and tight.
9. **LABELS AND TAGS (WEEKLY).** Check for presence and legibility of labels. Replace if damaged or missing.
10. **WIRE ROPE LINE SPEED MONITOR.** Verify Line Speed Monitor displays line speed and overspeed alarm lights at 100 feet per minute (+/- 10 feet) (30.5 metres per minute; +/- 3 metres). If battery charge light is on, charge battery.
11. **WINCH EXHAUST AND MUFFLER.** Visually inspect exhaust hoses, connections and muffler for damage. Ensure piping and muffler are correctly installed and direct exhaust away from winch operator. Operator noise levels must not exceed 90 dBA over an 8 hour period (Time Weighted Average (TWA)).
12. Ensure electrical ground (earth) is firmly connected and that wire is in good condition. Replace wire if corroded or damaged.

Winch Initial and Quarterly Inspections

Disassembly may be required as a result of inspection findings or in order to properly inspect the individual components. Maintain written records of initial and quarterly inspections to provide an accumulative basis for continuing evaluation. Inspect all items listed in "Weekly Inspection." Also conduct the following:

1. **INITIAL INSPECTION.** Conduct all requirements of 'Winch Daily and Weekly Inspection' and 'Winch Testing'.
2. **QUARTERLY INSPECTION.** Conduct all requirements of 'Winch Daily and Weekly Inspection' and 'Winch Testing'.

Winches Not in Regular Service

1. Equipment which has been idle for a period of one week or more, but less than one month, shall be given an inspection conforming to the requirements of "Daily and Weekly Inspections" before being placed in service.
2. Equipment which has been idle for a period of over one month shall be given a complete inspection conforming with the requirements of "Initial and Quarterly Inspections" before being placed in service.

INSPECTION AND MAINTENANCE REPORT

Ingersoll-Rand Force 5 Series Ansi Manrider® Air Winch

| | |
|---|--|
| Model Number: | Date: |
| Serial Number: | Inspected by: |
| Reason for Inspection: (Check Applicable Box) | |
| <input type="checkbox"/> 1. Scheduled Inspection (___ Weekly ___ Quarterly ___ Initial) <input type="checkbox"/> 2. Discrepancy(s) noted during Daily Inspection <input type="checkbox"/> 3. Discrepancy(s) noted during maintenance <input type="checkbox"/> 4. Other: _____ | Operating Environment: Normal ___ Heavy ___ Severe ___ |

Refer to the Parts, Operation and Maintenance Manual "INSPECTION" section for general inspection criteria. Also, refer to appropriate National Standards and codes of practice. If in doubt about an existing condition contact the nearest Ingersoll-Rand Distributor or the factory for technical assistance.

| COMPONENT | CONDITION | | CORRECTIVE ACTION | | NOTES |
|--|-----------|------|-------------------|---------|-------|
| | Pass | Fail | Repair | Replace | |
| Side Rails and End Uprights | | | | | |
| Manual Drum Band Brake (150% Load Test) | | | | | |
| Automatic Drum Band Brake (150% Load Test) | | | | | |
| Drum Band Brakes (Visual Inspection) | | | | | |
| Motor | | | | | |
| Limit Switches | | | | | |
| Controls | | | | | |
| Air System | | | | | |
| Fasteners | | | | | |
| Reduction Gears | | | | | |
| Labels and Tags | | | --- | | |
| Shafts | | | | | |
| Wire Rope Anchor Wedge | | | --- | | |
| Line Speed Monitor and Overspeed Alarm | | | --- | | |
| Other Components (list in NOTES section) | | | | | |

| TESTING | Pass | Fail | NOTES |
|-----------------------------------|------|------|-------|
| Operational (No Load) | | | |
| Operational (10% Load) | | | |
| Operational (Maximum Test Load *) | | | |

* Maximum winch operational test load is 125% of rated line pull.
 Maximum brake test load is 150% of rated line pull; perform by raising the test load approximately 4 to 6 inches (100 to 150 mm).

WINCH TROUBLESHOOTING

This section provides basic troubleshooting information. Determination of specific causes to problems are best identified by thorough inspections performed by personnel instructed in safety, operation and maintenance of this equipment. The chart below provides a brief guide to common winch problems, probable causes and solutions.

| PROBLEM | CAUSE | SOLUTION |
|---|--|--|
| Winch will not operate. | No air supply to winch. | Check air supply line connections and hoses. |
| | Winch is overloaded. | Reduce load to within rated capacity. |
| | Automatic drum band brake does not release. | Pressurize brake release port and check for leakage. Replace brake piston seals if leakage is found. |
| | Limit switch engaged. | Shift pilot valve throttle lever in opposite direction. If winch operates, adjust limit switch settings. |
| | Shipping plugs may still be in place. | Remove shipping plugs in valve and motor exhaust ports. |
| Load continues to move when winch is stopped. | Automatic drum band brake is slipping. | Check brake band adjustment and brake band lining wear. |
| | Winch is overloaded. | Reduce load to within rated capacity. |
| | Pilot air throttle control valve sticking. | Disassemble, inspect and repair the pilot air throttle control valve. |
| Winch does not lift load. | Motor may be damaged. | Remove and disassemble motor. Examine all parts and replace any that are worn or damaged. |
| | Insufficient air supply. | Verify air supply pressure and volume at winch inlet meets the requirements listed in the "SPECIFICATIONS" section. Clean air line filter. |
| | Automatic drum band brake or optional disc brake do not release. | Disassemble, inspect and repair the automatic drum band and/or optional disc brake. |
| Throttle lever moves but winch does not operate. | Motor may be damaged. | Disassemble and clean the motor and replace any broken or damaged parts. |
| | Insufficient air supply. | Ensure the air pressure at the winch inlet is at least 90 psig (6.2 bar) at rated volume. Clean air line filter. |
| | Limit switch engaged. | Shift pilot valve throttle lever in opposite direction. If winch operates, adjust limit switch settings. |
| Motor runs hot or makes excessive noise during operation. | Low oil level. | Check oil level in the motor. Add oil as required to obtain the proper level. |
| | Improper lubrication. | Replace oil with type recommended in the "LUBRICATION" section. |
| | Water in oil. | Drain and refill with recommended oil. Operate winch with no load slowly, in both directions. If noise still exists or motor overheats disassemble and repair motor. |
| | Damaged or broken piston or connecting rod. | Disassemble and repair motor. |
| Winch runs slow. | Improper hose or fitting sizes. | Check fittings, connections and hoses for correct size and length. Replace parts that may cause restricted air flow. Inspect air line filter. |
| | Motor may be damaged. | Remove and disassemble motor as described in the "MAINTENANCE" section. Inspect all parts and replace all worn or damaged parts. |

| PROBLEM | CAUSE | SOLUTION |
|-------------------|----------------------|---|
| Air lines freeze. | Water in air supply. | Install or drain air system moisture traps, moisture collecting air receivers and compressor aftercoolers. After corrective action has been taken, disconnect lines at winch inlet and purge with clean, dry air or nitrogen. |

Automatic Drum Brake:

| | | |
|----------------------------------|--|---|
| Brake cylinder will not release. | Drum brake out of adjustment. | Adjust drum brake to maintain correct cylinder stroke. |
| | Damaged or leaking cylinder seals. | If air is noticed escaping from the cylinder breather when attempting to release the brake replace or repair cylinder. |
| | Dirty filter in air supply. | Clean or replace filter. |
| | Faulty dump valve. | Check dump valve exhaust port. Air should exhaust when control valve handle is in neutral. If no air escapes, replace dump valve. |
| | Low air supply pressure. | Ensure supply air pressure at the brake inlet is at least 50 psig (3.4 bar). |
| | No release pressure at the brake port. | Verify proper operation of winch controls. |

Automatic Disc Brake:

| | | |
|-------------------------|--|--|
| Brake fails to release. | Low air supply pressure. | Ensure supply air pressure at the brake inlet is at least 50 psig (3.4 bar). |
| | Leaking 'O' ring seals. | Disassemble and inspect brake sealing surfaces. Replace 'O' ring(s). |
| | No release pressure at the brake port. | Verify proper operation of winch controls. |

Limit Switch

| | | |
|-----------------------------------|--------------------------|---|
| Limit switch fails to stop winch. | Limits not properly set. | Adjust limit switch settings. Refer to "MAINTENANCE" section. |
| | Damaged limit switch. | Disassemble, inspect and repair limit switch. |

Line Speed Monitor and Overspeed Indicator

| | | |
|----------------------------|-------------------------------------|--|
| Monitor does not indicate. | Sensor not reading drum revolution. | Ensure sensor head is clean, drum capscrews are clean and that sensor/capscrew clearance is adjusted to 0.2 inch (+/- 0.1 inch) [5 mm (+/- 2.5 mm)]. |
| | Battery low. | Recharge battery. Refer to "MAINTENANCE" section. |
| | Loose or broken connection. | Ensure cable from indicator to sensor is properly connected. |

WINCH MAINTENANCE

⚠ WARNING

- Never perform maintenance on the winch while it is supporting a load.
- Before performing maintenance, tag controls:
DANGER - DO NOT OPERATE - EQUIPMENT BEING REPAIRED.
- Only allow service personnel trained in safety and maintenance on this winch to perform maintenance.

Reduction Gear Assembly

It is recommend that the first oil change be done after approximately 50 hours initial operation. Always inspect removed oil for evidence of internal damage (metal shavings, dirt, water, etc.).

Check the oil in the reduction housing as recommended in the "LUBRICATION" section. If low, replenish. The oil should be changed at least once every year.

Refer to the "LUBRICATION" section for recommended oil.

| INTERVAL | MAINTENANCE CHECK |
|--|--|
| Start of each shift (Operator or Maintenance Personnel) | Make a thorough visual inspection of the winch for damage. Do not operate the winch if damaged. |
| | Operate the winch at low RPM in both directions. Winch must operate smoothly without sticking, binding or abnormal noises. Check the operation of the brake(s). |
| 3 Months (Maintenance Personnel) | Inspect the drum brake friction linings. Clean or replace parts as required. Adjust drum brake as necessary. |
| Yearly (Maintenance Personnel) | Inspect the winch gearing, shafts and bearings for wear and damage. Repair or replace as necessary. |
| | Check all the supporting members, including the foundation, fasteners, nuts, sheaves and rigging, etc. for indications of damage or wear. Repair or replace as required. |

Winch Adjustments

Disc Brake (optional feature) Adjustment

Brake adjustment is **not** required. If the disc brake does not hold the rated load disassemble and repair.

If the brake assembly is removed or repaired ensure the breather is installed and located at the top of the brake housing during reassembly.

Manual Drum Brake Adjustment

1. Release wire rope tension on the drum.
2. Raise handle (104) to free brake bands.
3. Remove cotter pin (102) and pin (101).
4. Rotate link stud (103) clockwise to increase brake torque.
5. Install pin (101) and check adjustment.
6. Brake should be adjusted until brake lever over center position can be attained with 50 to 100 lb. (23 to 45 kg) force on the handle.
7. Install cotter pin (102) when adjustment is completed.
8. Test brake as described in 'Winch Testing' in the "MAINTENANCE" section. Readjust if necessary.

⚠ CAUTION

- When any part of the brake lining measures **0.062 inch (2 mm) or less**, brake bands (128) or linings must be replaced.

Automatic Drum Brake Adjustment

1. Remove cotter pin (102) at adjustment clevis (107).
2. Apply air to the brake cylinder and remove pin (106) to disconnect clevis (107) from brake lever (105).
3. Clevis (107) adjustments:
 - a. To decrease brake torque, turn adjustment clevis clockwise to increase cylinder (110) rod extension.
 - b. To increase brake torque, turn clevis counterclockwise to decrease cylinder (110) rod extension.
4. Assemble clevis (110) to brake lever (105) with pin (106). Release air to brake cylinder.
5. Test brake as described in 'Winch Testing' in the "MAINTENANCE" section. Readjust if necessary.
6. Install cotter pin (102) to secure clevis to brake lever when adjustments are complete.

Pilot Air Control Valve Adjustment

If winch operating speeds differ from performance specifications the pilot air control valve may require adjustment. Loosen nut and adjust adjusting screw, located in the valve end cap, until drum speed for no-load haul in equals the drum speed for full load pay out.

Limit Switch Adjustment

(Refer to Dwg. MHTPA0607)

⚠ CAUTION

- Maintain at least **4 tight wraps of wire rope on the drum at all times**. Ensure wire rope top layer is a minimum of **2 inches (50 mm) below drum flange edge**. Refer to Dwg. MHTPA0498.

The FA2.5MRA air lines and connections are color coded to assist in assembly. Refer to the following table in determining air connections by color coding.

Adjustments described as viewed when facing the limit switch assembly from the automatic brake cylinder side of the winch.

Winch Air System Color Code

| Winch Direction | Limit Switch Connections | Pilot Air Valve Manifold to Throttle |
|-----------------|--------------------------|--------------------------------------|
| Haul In | Yellow | Brown |
| Pay Out | Green | Blue |

| Winch Direction | Supply Air | Limit Switch Setscrews |
|-----------------|------------|------------------------|
| Haul In | Red | Red |
| Pay Out | | Blue |

Limit Switch Adjustment

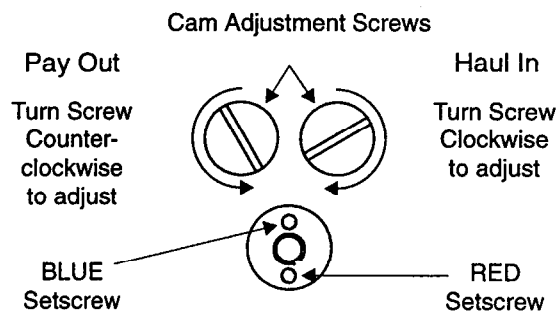

(Dwg. MHTPA0607)

To set winch maximum wire rope pay out limit switch:

1. Remove access plate (522) from top of limit switch.
2. Loosen the blue setscrew in the center of the limit switch, below the access plate.
3. Position winch wire rope at desired pay out position.
4. Rotate the left cam adjustment screw counterclockwise until it fully activates the cutoff valve, causing system air to vent. 2-3/4 turns of the cam adjustment screw are required for each full cam revolution.
5. Hold the cam adjustment screw in position (venting air) and tighten the blue setscrew.
6. Adjust haul in limit switch. Test winch setpoints by operating the winch through three complete cycles to ensure consistent limit switch operation within +/- 2 feet (2/3 m) of setpoints.
7. Install access plate (522) when final adjustments are complete.

To set winch maximum wire rope haul in limit switch:

1. Remove access plate (522) from top of limit switch.
2. Loosen the red setscrew in the center of the limit switch, below the access cover.
3. Position winch wire rope at desired pay out position.

4. Rotate the right cam adjustment screw clockwise until it fully activates the cutoff valve, causing system air to vent. 2-3/4 turns of the cam adjustment screw are required for each full cam revolution.
5. Hold the cam adjustment screw in position (venting air) and tighten the blue setscrew.
6. Adjust haul in limit switch. Test winch setpoints by operating the winch through three complete cycles to ensure consistent limit switch operation within +/- 2 feet (2/3 m) feet of setpoints.
7. Install access plate (522) when final adjustments are complete.

Wire Rope Line Speed Monitor and Overspeed Alarm Adjustment

Line speed monitor adjustments are limited to the placement of the sensor. Adjustments to the indicator set points established at the factory should not be attempted. To change line speed monitor set points contact your nearest **Ingersoll-Rand** distributor or the factory.

1. The sensor attaches to the assembly bracket (616) and faces the drum reduction gear mounting capscrews (45).
2. Install the sensor and adjust to ensure a clearance of 0.2 inch (+/- 0.1 inch) [5 mm (+/- 2.5 mm)] between the sensor and the drum reduction gear mounting capscrew heads. Refer to Dwg. MHTPA0602.

Overspeed Indicator Sensor Clearance

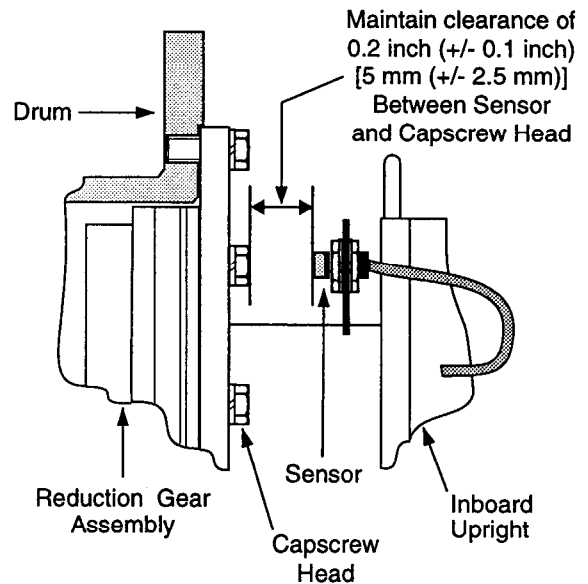

(Dwg. MHTPA0602)

Line Speed Monitor and Overspeed Alarm Battery Charging Procedure

The Line Speed Monitor battery should be recharged at least once every two weeks. If required the monitor assembly may be removed from the winch and transported to an electrical source for battery charging.

To charge connect the battery charger unit to the monitor and to a 110 volt (ac) electrical source. Charge the battery for 24 hours.

Disassembly

General Disassembly Instructions

The following instructions provide the necessary information to disassemble, inspect, repair, and assemble the winch. Parts drawings are provided in the parts section.

If a winch is being completely disassembled for any reason, follow the order of the topics as they are presented. It is recommended that all maintenance work on the winch be performed in a clean dust free work area.

In the process of disassembling the winch, observe the following:

1. Never disassemble the winch any further than is necessary to accomplish the needed repair. A good part can be damaged during the course of disassembly.
2. Never use excessive force when removing parts. Tapping gently around the perimeter of a cover or housing with a soft hammer, for example, is sufficient to break the seal.
3. Do not heat a part with a flame to free it for removal, unless the part being heated is already worn or damaged beyond repair and no additional damage will occur to other parts.

In general, the winch is designed to permit easy disassembly and assembly. The use of heat or excessive force should not be required.

4. Keep the work area as clean as practical, to prevent dirt and other foreign matter from getting into bearings or other moving parts.
5. All seals and 'O' rings should be discarded once they have been removed. New seals and 'O' rings should be used when assembling the winch.
6. When grasping a part in a vise, always use leather-covered or copper-covered vise jaws to protect the surface of the part and help prevent distortion. This is particularly true of threaded members, machined surfaces and housings.
7. Do not remove any part which is a press fit in or on a subassembly unless the removal of that part is necessary for repairs or replacement.
8. When removing ball bearings from shafts, it is best to use a bearing puller. When removing bearings from housings, drive out the bearing with a sleeve slightly smaller than the outside diameter of the bearing. The end of the sleeve or pipe which contacts the bearing must be square. Protect bearings from dirt by keeping them wrapped in clean cloths.

Winch Disassembly

(Refer to Dwg. MHTPA0669)

1. Remove the wire rope from the drum.
2. Operate the winch to position reduction gear drain plug (48) at its lowest position.
3. Relieve pressure in the air lines by operating the winch control several times after the air supply has been turned off.

WARNING

• **Shut off, bleed down and disconnect the air supply line before performing any disassembly procedures.**

4. Disconnect and tag the air lines.
5. Remove the winch from its mounting and take to a suitable work area before beginning disassembly.
6. Remove motor lower case drain plug (225) on motor housing (217) and allow the oil to drain into a suitable container. Loosen fill cap (210) to vent the motor housing.
7. Drain oil from the reduction gear assembly by removing one plug (48) when positioned at it's lowest point, and one plug (48) from it's highest point to vent. Refer to Dwg. MHTPA0140 in the "LUBRICATION" section. If the winch is equipped with a drum band brake the winch outboard end (opposite the motor end) must be elevated to prevent draining oil from contaminating the brake band lining.
8. For winches with an optional disc brake remove pipe plug (24) in brake housing (21) to drain brake oil. The winch outboard end (opposite the motor end) must be elevated to prevent draining oil from contaminating the drum brake band lining.

WARNING

• **The FA2.5MRA air motor weighs approximately 260 lbs. (118 kg). Adequately support the air motor before removing the motor mounting capscrews.**

9. Remove drum band brakes, drum guard, limit switch, line speed monitor and any other externally mounted piping or winch attachments.
10. Remove the capscrews (4) and lockwashers (3) securing the motor assembly to the motor adapter (6). Using a hoist to support the motor, pull the motor straight away from the winch. Reference the **Motor Disassembly** section if motor disassembly is required.

Instructions 11 through 17 apply only to winches with an optional disc brake. Note the position of all brake parts for reassembly.

11. Alternately and evenly loosen the eight capscrews (1) until the brake spring compression has been relaxed. Remove capscrews, motor adapter (6) and brake reaction plate (8).
12. Remove the brake housing (21). If the brake housing sticks, tap it with a brass hammer until the parts separate.
13. Remove the three friction plates (16) and two drive plates (17).
14. Remove springs (9) from brake piston (10).
15. Remove brake piston (10) from brake housing (21). Tap lightly with a plastic mallet to separate parts if necessary.
16. Remove seals (11) and (12) from brake piston (10).
17. Loosen the capscrew in collar (18) and slide collar from shaft (35) with the splined hub (19). Remove retainer ring (32) and spacer (34) from shaft (35).

18. Remove retainer ring (36) from the bore of the drum shaft (41).
19. Pull shaft and bearing assembly from the drum shaft (41).
20. Support the drum (80) and remove capscrews (39) from the drum shaft (41). Pry drum shaft (41) from the inboard upright (42).
21. Remove capscrews (85) and lockwashers (46) which secure the side rails (82 and 83) to the inboard upright (42). Drive out dowel pins (87).
22. Remove inboard upright (42).
23. Disconnect limit switch hoses (354, 355 and 359) from fittings (526). Hoses and fittings should be plugged or taped shut to maintain air system cleanliness. Disconnect coupling (507).
24. Remove capscrews (97), lockwashers (96), limit switch with bracket (504), spacers (503) and end cover (95) from the outboard upright (84). Place limit switch assembly in a safe place.
25. Remove capscrews (93) and bearing retainer (501) from the drum (80).
26. Remove drum and reduction gear assembly.
27. Remove the remaining capscrews (85) and lockwashers (46) which attach the side rails (82) and (83) to the outboard upright (84). Drive out dowel pins (87).
28. Remove bearing (86) and seal (99) from outboard upright (84).
29. Remove capscrews (45) and lockwashers (46) from the gear carrier (47). Lift reduction gear assembly from the drum (80). To disassemble reduction gear refer to the 'Reduction Gear Disassembly' section.

Manual and Automatic Drum Brake

(Refer to Dwg. MHTPB0636)

Actuator Disassembly:

1. Automatic Brake
 - a. Disconnect and remove hose, fittings and dump valve (112) from the cylinder (110).
 - b. Remove cotter pin (102), washer (129) and pin (101) from the link stud (103) and brake band (128).
 - c. Remove cotter pin (102) and pin (106). Separate the clevis (107) from brake lever (105).
 - d. Remove cylinder (110) from bracket (118).
2. Manual Brake:
 - a. Remove cotter pin (102) and pin (101) from handle (104) then remove handle (104) from brake band (128).

Brake Band Disassembly:

3. Remove capscrews (119), lockwashers (117) and stop plate (126).
4. Remove cotter pins (102) and pins (121) which locate arms (124) with pivot brackets (122).
5. Use a hoist to raise the winch approximately 6 inches (15 cm). Separate the brake band (128) halves and rotate the brake band assembly slowly until it can be removed from the drum (80).
6. Remove cotter pins (102) and pins (121) so brake band halves (128) can be removed from the arm (124). Lower winch when brake band assembly has been removed.

Reduction Gear Disassembly

(Refer to Dwg. MHTPA0669)

NOTICE

• It is important to maintain a clean work area when servicing the reduction gear assembly.

1. Place the reduction gear assembly on a clean work bench such that the end containing bearing (49) is down.
2. Remove capscrews (75) and pry off cover (73).
3. Remove ring gear (63), planet assembly (67) and sun gear (69).
4. Remove and discard 'O' rings (51) from ring gear (63).
5. Remove four pins (74) from between ring gear (63) and spacer (71) and store in a safe place.
6. Remove spacer (71), ring gear (53), dowel pins (52) and sun gear (66).
7. If required, remove thrust plate (55) from sun gear (66). Remove and discard 'O' rings (51) from ring gear (53).
8. Remove planet assembly (54).
9. Remove retainer ring (50) and bearing (49) from gear carrier (47).

NOTICE

• Do not disassemble planetary gears from their carriers unless required to replace damaged parts. For information on the planetary assemblies (54 and 67) contact your Ingersoll-Rand distributor or the factory.

FA2.5 Motor Disassembly

(Refer to Dwg. MHTPA0690)

1. Remove the five capscrews (255) from the exhaust flange (254).
2. Remove the rotary valve housing (247) by pulling it out of the motor housing (217) as an assembly with the exhaust flange (254).

⚠ CAUTION

• Do not remove the exhaust flange (254) until the rotary valve (250) has been removed from the rotary valve housing (247).

3. Remove rotary valve (250) by pulling it out from the assembly through the motor housing end of the rotary valve housing (247).
4. Remove exhaust flange (254) and throttle valve assembly (355).
5. Remove each cylinder head (201) by removing the four capscrews (200). Remove head gasket (209).
6. Remove mounting adapter (6) by removing capscrews and then pulling mounting adapter straight off.
7. Pull the cylinder liner (208) straight out.

- Position the piston (204) at the top of its stroke. In this position, with the cylinder liner pulled out in step 7, the wrist pin (203) can be removed. Remove one retainer ring (205) from either side of piston (204). Push the wrist pin (203) out by hand from one side. If the wrist pin is too tight it is acceptable to carefully heat the piston to 200° F (93° C) or less and then push the wrist pin out.

NOTICE

• **If piston, wrist pin, connecting rod or cylinder liner are to be re-assembled, number each set. Also add radial alignment marks for each piston and cylinder liner to the motor housing.**

- Remove the remaining cylinder liners and pistons as described in steps 7 and 8. To remove the crank assembly, all pistons and cylinder liners must be removed.
- Crank assembly (231) can now be removed with the oil slinger (230) by pulling straight out from the motor housing (217). Use care while guiding the connecting rods (206) through the inside of the motor housing.

Crankshaft Disassembly

- Remove cotter pin (236) and the pin nut (237).
- Remove lock pin (235) by carefully driving it out of its location. Use care not to damage the threads.
- Pull the crankshaft valve end (231) off the crankshaft.
- Remove connecting rod rings (234), connecting rod bushing (233), sleeve (232) and connecting rods (206). Record the five connecting rod (206) numbers and foot directions so they can be re-installed in the same order.
- Oil slinger (230) does not have to be removed unless damaged. If removal is required, heating of the five screws (229) may be necessary to loosen the Loctite® connection.

Cleaning, Inspection and Repair

Clean all winch component parts in solvent (except the drum brake bands and disc brake friction plates). The use of a stiff bristle brush will facilitate the removal of accumulated dirt and sediments on the housings, frame and drum. If bushings have been removed it may be necessary to carefully remove old Loctite® from the bushing bores. Dry each part using low pressure, filtered compressed air. Clean the drum brake band using a wire brush or emery cloth. Do not wash the drum brake band in liquid. If the drum brake band lining is oil soaked, it must be replaced.

Inspection

All disassembled parts should be inspected to determine their fitness for continued use. Pay particular attention to the following:

- Inspect all gears for worn, cracked, or broken teeth.
- Inspect all bushings for wear, scoring, or galling.

- Inspect shafts for ridges caused by wear. If ridges caused by wear are apparent on shafts, replace the shaft.
- Inspect all threaded items and replace those having damaged threads.
- Inspect the drum band brake lining for oil, grease and glazing. If the drum band brake lining is oil-soaked replace the brake bands as a set. Remove glazed areas of band brake lining by sanding lightly with a fine grit emery cloth.
- Measure the thickness of the drum band brake lining. If the drum brake band linings are less than 0.062 inch (2 mm) thick anywhere along the edges replace the brake bands (128) as a set.

Repair

Actual repairs are limited to the removal of small burrs and other minor surface imperfections from gears and shafts. Use a fine stone or emery cloth for this work.

- Worn or damaged parts must be replaced. Refer to the applicable parts listing for specific replacement parts information.
- Inspect all remaining parts for evidence of damage. Replace or repair any part which is in questionable condition. The cost of the part is often minor in comparison with the cost of redoing the job.
- Smooth out all nicks, burrs, or galled spots on shafts, bores, pins, or bushings.
- Examine all gear teeth carefully, and remove nicks or burrs.
- Polish the edges of all shaft shoulders to remove small nicks which may have been caused during handling.
- Remove all nicks and burrs caused by lockwashers.

Winch Assembly

General instructions

- use all new gaskets and seals.
- replace worn parts.
- assemble parts using match marks attached during disassembly. Compare replacement parts with originals to identify installation alignments.
- lubricate all internal parts with a mixture of half SAE 20W oil and half molybdenum disulfide lubricant compound (eg. STP).

FA2.5 Motor Assembly

(Refer to Dwg. MHTPA0690)

- Assemble throttle valve assembly (355) and gasket (248) to rotary valve housing (247). Install exhaust flange (254) to rotary valve housing (247). Secure with capscrews (255).
- Tighten capscrews (255) to 25 ft. lbs. (34 Nm).
- Assemble bearing (252) to rear of rotary valve (250) by pressing only on the inner race of the bearing. With the exhaust flange (254) down install rotary valve (250) into rotary valve housing (247). Slide rotary valve out of the rotary valve housing far enough to install seal ring (251) on the crank shaft end of the rotary valve (250). Slide rotary valve back into the rotary valve housing (247).
- Install 'O' ring (244) into motor housing (217).

5. Install the rotary valve housing gasket (243) onto rotary valve housing (247). With the exhaust flange down on the bench, install motor housing (217) on to rotary valve housing (247). Check for any evidence of damage to 'O' ring (244) when the rotary valve housing is fully engaged. Install and tighten capscrews (253) to 50 ft. lbs. (68 Nm).
6. If removed, press crank bearing (228) on crank assembly (231). Apply pressure only on the inner race of the bearing.
7. Place crank assembly (231) on a work bench with the oil slinger (230) down and slide the sleeve (232) (with tang up) on the crankpin.
8. Slide connecting rod bushing (233) over the sleeve (232) and first connecting rod ring (234) with the chamfer up.
9. Install the connecting rods (206) in the same order as removed, with all feet pointing in the same direction, using the first connecting rod ring (234) to hold one side of the connecting rod feet.
10. Slide the second connecting rod ring (234) over the other side of the connecting rod feet with the chamfer on the ring facing down (toward the stem of the connecting rod).
11. Slide the crank shaft valve end over the crank pin while simultaneously aligning the tang on the sleeve (232) with the slot in the crank shaft.
12. Rotate and position the crank shaft valve end relative to the crank pin to allow installation of the lock pin (235).
13. Tap the lock pin (235) in place and install the pin nut (237). Torque nut to 60 ft lbs (81 Nm).
14. Install cotter pin (236).
15. Install roll pin (240) and bearing (228) into the valve end of the crank shaft.
16. Check that all connecting rods move freely around the crank. Position the crank assembly (231) into the motor housing (217). Ensure the bearing (228) is seated and connecting rods (206) are centered in the cylinder holes.

NOTICE

• **Make certain that the roll pin (240) and the three lugs on the rotary valve (250) line up with the corresponding hole and lugs on the crank shaft.**

• **Do not allow the rotary valve (250) to slide back in rotary valve housing (247). If the rotary valve slides in too far, the seal ring (251) will lock-up in the internal grooves of the rotary valve housing (247) and restrict further assembly.**

17. Rotate the crank assembly until one connecting rod (206) is at the top of its stroke. Install a piston (204) with its rings (202 and 207) to the connecting rod (206) with wrist pin (203) and retaining rings (205).
18. Install a new cylinder head gasket (209) before installing the cylinder liner (208).
19. Install the cylinder liner (208) over the piston (204) by compressing both piston rings (202 and 207) with a single band ring compressor.

20. Install cylinder head (201) over the cylinder and secure cylinder head to motor housing (217) with four capscrews (200). Torque capscrews to 60 ft lbs (81 Nm).
21. Repeat Steps 17 through 20 with the remaining cylinders.

NOTICE

• **When installing the two lowest cylinder heads (201), use seal washers on capscrews (200).**

22. Rotate motor by hand. Motor should rotate without binding.
23. Install mounting flange (216) and gasket (226) on the front of the motor housing (217). Make sure notches on both parts are aligned.
24. Lightly lubricate 'O' ring (5) and install in groove on motor adapter (6).

NOTICE

• **'O' ring, item 5 listed in step 24 refers to part number 51460 as shown on winch assembly Dwg. MHTPA0669. This part must be placed between the mounting flange (216) and motor adapter (6).**

25. Temporarily install capscrews and nuts finger tight to retain motor adapter (6).
26. Install eye bolts (213) and vent cap assemblies (210) in the motor housing (217).
27. Ensure oil drain and level plugs are installed.

Reduction Gear Assembly

(Refer to Dwg. MHTPA0669)

1. Lubricate and install 'O' rings (51) on ring gear (63). Assemble ring gear (63), cover (73) and spacer (71). Check dowel and capscrew holes are aligned.
2. Drive dowels (74) into assembly until flush with the cover (73).
3. Position assembled parts vertically with the cover (73) down. Install planet assembly (67) and gear (69) into ring gear (63).
4. Press bushing (55) into sun gear (66) and install sun gear (66) into planet assembly (67).
5. Lubricate and install 'O' rings (51) on ring gear (53). Install ring gear on spacer (71) being careful not to damage the 'O' rings. Align dowel and capscrew holes.
6. Tap dowels (52) into ring gear (53) and spacer (71). Leave approximately 0.37 inch (9 mm) exposed for engagement with carrier (47).
7. Install planet assembly (54) so planet gear teeth mesh in the ring gear (53) and with the sun gear (66).
8. Press bearing (49) into bore of gear carrier (47). Install retainer ring (50).
9. Install gear carrier (47) on ring gear (53) being careful not to damage 'O' ring (51). Check capscrew and dowel holes are lined up. Lightly coat capscrews (45) with Loctite® 242. Install capscrews and lockwashers (46). Do not tighten.

10. Tap dowels (87) through ring gear (53) and gear carrier (47) until they are just below the flange surface of the gear carrier (47).
11. Lightly coat capscrews (75) with Loctite® 242 and install. Torque capscrews to 32 ft lbs (43 Nm).

Manual and Automatic Drum Brake Assembly

(Ref. Dwg. MHTPB0636)

1. Install pivot bracket (122) on the end of arm (124) with pin (121), washer (123) and cotter pin (102). Recessed side of the threaded hole must be toward the band side.
2. Install connecting link (125) on the arm (124) and secure in position with pin (121), washer (123) and cotter pin (121). Assemble connecting link (125) so curved surface matches contour of the brake band.
3. Install halves of brake band (128) to the connecting link (125) and secure with pins (101), (121) and cotter pins (102).
4. Lift the winch assembly, with a suitable hoist, approximately 6 inches (15 cm) off the floor or work bench.
5. Position the brake band sub-assembly around the brake diameter on the drum (80) so the arm (124) lays at the bottom. When positioned, lower the winch.
6. Mount pivot bracket (122) on the inside surface of the side rail (82) and secure in position with capscrews (116) and lockwashers (117).
7. Screw link stud (103) into handle (104) and install the handle in the lug on the end of the brake band (128). Lubricate the pivot points being careful not to get grease on the brake band lining.
8. Pull the halves of the brake band together and install pin (101) through the lug on band (128) and the adjusting screw (103) of the handle assembly.
9. Install stop plate (126) on the inside of the side rail (83) with capscrews (119) and lockwashers (117). Install adjusting screw (127) and locknut (120) through the side rail (131) and stop plate (126) until it contacts the arm (124).
10. To adjust brake refer to 'Winch Adjustments' in the "MAINTENANCE" section.

Automatic Drum Brake Actuator Assembly:

11. Install bracket (118) on side rail (82) with capscrews (116) and lockwashers (117).
12. Screw nut (108) and clevis (107) onto cylinder rod.
13. Attach brake lever (105) to brake band (128).
14. Install cylinder (110) so it connects with bracket (118) and brake lever (105). Use pins (106) and cotter pins (102) to secure in position.
15. Install dump valve (112) fittings and hose (115) to the cylinder (110).
16. To adjust brake refer to 'Winch Adjustments' in the "MAINTENANCE" section.

Winch Assembly

(Refer to Dwg. MHTPA0669)

1. Clean both mating surfaces on the inboard upright (42) and install drum shaft (41) through the bore aligning the dowel pin holes.
2. Install dowel pins (40) flush or slightly below the surface of the drum shaft (41).
3. Install capscrews (39) with Loctite® 242 and torque to 44 ft lb (60 Nm).
4. Press bearing (37) onto the shaft (35) using Loctite® 609. Install retainer ring (38).
5. Install shaft (35) and bearing into the drum shaft (41) so smaller splined end enters first.

Instructions 6 through 16 cover winches with an optional disc brake. For winches without a disc brake skip to instruction 17.

6. Install sleeve (34), retainer ring (32) and splined hub (19) on shaft (35) so splined side of outside diameter goes on first. Seat splined hub (19) against retainer ring (32). Place collar (18) against splined hub and tighten capscrew to secure in place.
7. Lubricate and install 'O' ring (33) on hub of drum shaft (41).
8. Install brake housing (21) on drum shaft (41) being careful not to damage 'O' ring (33).
9. Position brake housing (21) so brake port is in the 2 o'clock position (as viewed from the motor end). Install drain plug (24) in brake housing (21) at the 6 o'clock position.
10. Install fitting (22) and breather (23) in the top of the brake housing (21).
11. Lubricate friction plates (16) with a light SAE 10W motor oil and install friction plates (16) and drive plates (17) in brake housing (21). Begin with a friction plate (16) then alternate between drive plates (17) and friction plates (16). Ensure the splined teeth mesh. Do not use force.
12. Lubricate and install seals (11) and (12) in brake piston (10) grooves so seal lips face each other. Do not overstretch seals during this procedure. Refer to Dwg. MHTPA0139.

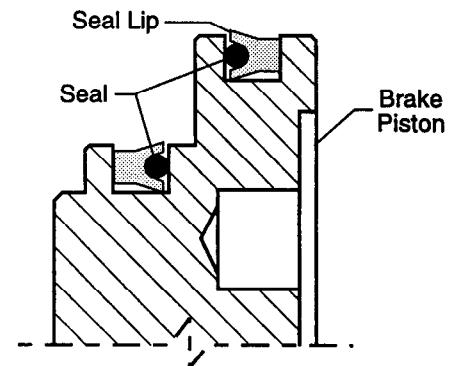

(Dwg. MHTPA0139)

13. Install brake piston assembly in brake housing (21) so stepped side enters first. Gently tap into position using a soft mallet until seated.

14. Install one brake spring (9) in each of the brake spring holes.
15. Lubricate and install 'O' ring (5) on motor adapter (6).
16. On winches with a disc brake position brake reaction plate (8) and motor adapter (6) on springs (9). Install capscrews (1) evenly to compress brake springs. Do not allow motor adapter to become cocked. Evenly hand tighten all capscrews before applying final torque.
17. On disc brake equipped winches install seal adapter (15) and shaft extender (7) on end of shaft (35).
18. Lubricate and install 'O' ring (5) in groove on the motor adapter (6).
19. Ensure oil seal (2) is installed in the bore of the motor assembly. Seal lip must face into the motor assembly.

WARNING

• **The FA2.5MRA air motor weighs approximately 260 lbs. (118 kg). Adequately support the air motor while installing the motor mounting capscrews.**

20. Mount motor assembly to motor adapter (6) with capscrews (4) and lockwashers (3). Torque capscrews (97) to 30 ft lbs (41 Nm).
21. On winches with a disc brake install fitting (31) in dump valve (30) and screw into the brake release port. Install vented fitting (29) in dump valve (30). Install fitting (25) in valve assembly (260) with elbow (26). Install steel tube (27) between fitting on the dump valve (30) and elbow (26).

Drum Assembly

1. Lay gear carrier (47) on the work bench and install bearing (49), retainer ring (50) and 'O' ring (51).
2. Align the dowel pins (52) and install reduction gear assembly to gear carrier (47).
3. Install capscrews (75) and torque to 32 ft lbs (43 Nm).
4. Clean surfaces of the drum (80) and gear carrier (47). Apply Loctite® 515 gasket sealant to drum mating surface. Lower reduction gear assembly into drum (80).
5. Lightly coat capscrews (45) with Loctite® 242 and install with lockwashers (46) Torque to 70 ft lbs (95 Nm).
6. Install fill/drain plugs (48) in gear carrier (47).
7. Apply a thin coat of Loctite® 609 to the outside of seal (43) and install in gear carrier (47).
8. Place drum in an upright position. Carefully lower inboard assembly into the drum (80) making sure splines on shaft (35) and drum shaft (41) mesh in the drum and reduction gear assembly.
9. Using a 'C' clamp, clamp the inboard flange assembly to the drum flange and place complete assembly in a horizontal position.
10. Clean seal surface and install oil seal (99) in outboard upright (84) with lip toward the drum.
11. Pack bearing (86) with grease and install in outboard upright (84).
12. Install outboard upright (84) on the drum end. Ensure assembly is kept centered on seal and journal during this step.

13. Install shaft retainer (501) using capscrews (93) with Loctite® 242. Torque to 30 ft lbs (41 Nm). Install oil seal (502).
14. Apply a light coat of Loctite® 515 sealant to the mating surface of the outboard upright (84) and install end cover (95), spacers (503) and bracket (504) using capscrews (97) and lockwashers (96). Apply a small amount of Loctite® 242 to capscrew (97) threads and torque to 30 ft lbs (41 Nm).
15. Install side rails to uprights and loosely secure using capscrews (85) and lockwashers (46).
16. Tap dowel pins (87) into position so they are flush with the side rails.
17. Apply Loctite® 242 to capscrews (85) and lockwashers (46) and torque to 70 ft lbs (95 Nm).

Limit Switch Assembly

(Refer to Dwg. MHTPB0633)

1. Install coupling (507) half on shaft retainer (501) shaft. Apply a small amount of Loctite® 242 to setscrew threads and install. Install rubber dampener.
2. Install coupling (507) half on limit switch (508) shaft. Apply a small amount of Loctite® 242 to setscrew threads and install.
3. Align limit switch (508) foundation holes with bracket (504) holes and install capscrews (509), lockwashers (505) and nuts (506).

Line Speed Monitor and Overspeed Alarm Installation

(Refer to Dwg. MHTPA0643)

1. The assembly bracket (613) attaches to the motor mounting flange and is secured with two capscrews (97).
2. Mount the line speed monitor (612) to the bracket and secure using capscrews (610) and nuts (611).
3. Install the sensor to the bracket assembly (616) and secure with lock nuts.

Winch Testing

Prior to initial use, all new, altered or repaired winches shall be tested to ensure proper operation at rated capacity.

1. **OPERATIONAL TEST.** Prior to initial use, all new, altered or repaired winches shall be tested to ensure proper operation.
 - a. Check oil level in motor, reduction gear assembly and disc brake are correct.
 - b. To initially 'break in' new or overhauled motors operate without load, in both directions, for 2 hours at 100 - 200 RPM.
 - c. **New Drum Brake Band Lining Run-in Procedure:** All new drum brake band linings require a 'run-in' period. Operate the winch without load in the payout direction while gradually applying the brake. Allow the brake to slip for approximately one minute. Winch motor may stall as drum brake band lining fully engages. Do not allow brake to overheat.
 - d. Check operation of brakes. Adjust if necessary as described in the "MAINTENANCE" section.
 - e. Check operation of limit switches, locking devices and all safety devices when equipped.

- f. Check foundation mounting fasteners are secure.
 - g. Install drum guard when provided.
2. **LOAD TEST.** Prior to initial use, all new, extensively repaired, or altered winches shall be load tested by or under the direction of a person trained in the operation and safety of this winch and a written report furnished confirming the rating of the winch. Load winch to **at least 100%, but not more than 125%** of the rated utility line pull and operationally test winch. Operate winch in both directions. Winch must operate smoothly, without indication of binding or malfunction.
- a. To test the winch apply the following load with the wire rope on the first layer of the drum:

| | |
|-----------------------|-----------------------------|
| | 100% Load |
| FA2.5MRA Winch | 3,500 lb. (1,558 kg) |
| | 150% Load |
| FA2.5MRA Winch | 4,375 lb. (1,985 kg) |

- 3. **LINESPEED INDICATOR AND OVERSPEED ALARM.** During operational and load tests, observe winch line speed. Maximum allowed line speed, when used as a **ManRider®**, should not exceed 100 ft./min (30.5 m/min). The visual overspeed alarm must activate when line speed reaches 100 ft./min (+/- 10 ft) (30.5 m/min (+/- 3 m)).
- 4. **BRAKES.** Test the drum automatic and manual band brakes independently. Each brake shall hold **150%** of rated load without slipping. Automatic drum band brake must stop and hold test load when the winch throttle lever is placed in the neutral position. Manual drum band brake must be able to stop and hold test load when the winch throttle lever is placed in the neutral position and brake is applied.
- 5. **LIMIT SWITCHES.** Operate winch in both directions to activate limit switches. Limit switches should engage at established settings (+/- 2 feet (2/3 m)), and prevent winch operation. Limit switch must reset after reversing winch operating direction and allowing drum to turn approximately three full revolutions.

WINCH ASSEMBLY DRAWINGS AND PARTS LISTS TABLE OF CONTENTS

| Description | Page No. |
|---|-----------------|
| Winch Assembly Drawing (MHTPA0669) | 32 |
| Winch Assembly Drawing Parts List | 33 |
| Motor Assembly Drawing (MHTPA0690) | 34 |
| Motor Assembly Parts List | 35 |
| Drum Brake Assembly Drawing (MHTPB0636) | 36 |
| Drum Brake Assembly Parts List | 37 |
| Limit Switch Assembly Drawing (MHTPB0633) | 38 |
| Limit Switch Assembly Parts List | 39 |
| Drum Guard Assembly Drawing (MHTPA0205) and Parts List | 40 |
| Pilot Air Control Valve Assembly Drawing (MHTPA0141) and Parts List | 41 |
| Pilot Air Valve Plumbing Assembly Drawing (MHTPB0632) | 42 |
| Pilot Air Valve Plumbing Assembly Parts Lists | 43 |
| Line Speed Monitor Assembly Drawing (MHTPA0643) and Parts List | 44 |
| Muffler Assembly Drawing (MHTPA646) and Parts List | 45 |
| Disc Brake (optional) Assembly Drawing (MHTPA0152) and Parts List | 46 |
| Winch Accessories Parts List | 47 |
| Winch Labels and Tag Drawing (MHTPA0759) and Parts List | 47 |

WINCH ASSEMBLY DRAWING

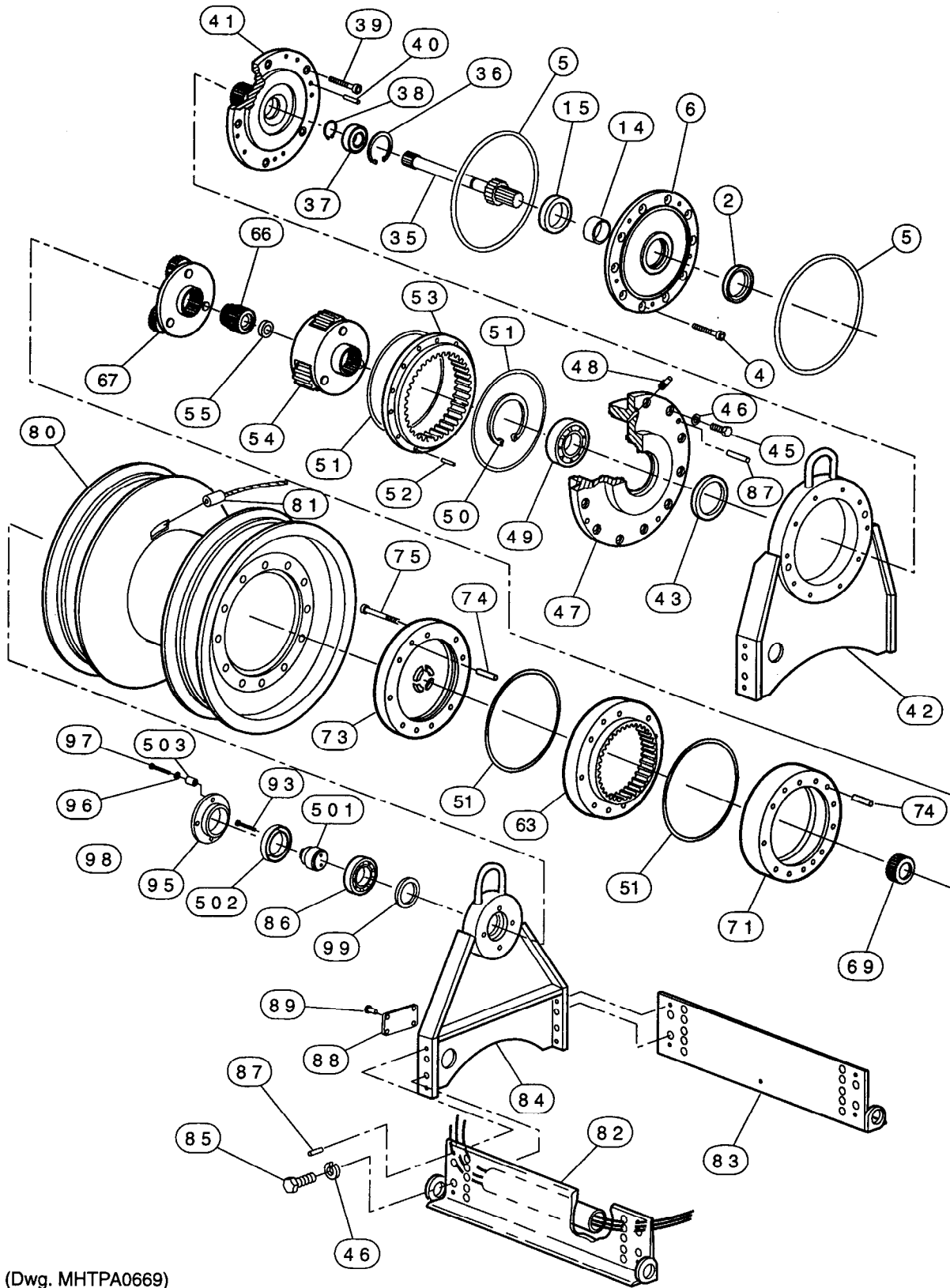

(Dwg. MHTPA0669)

WINCH ASSEMBLY PARTS LIST

| ITEM NO. | DESCRIPTION OF PART | QTY TOTAL | PART NUMBER | ITEM NO. | DESCRIPTION OF PART | QTY TOTAL | PART NUMBER |
|-------------------------------------|---------------------|-----------|-------------|----------|--------------------------------------|-----------|-----------------|
| • 2 | Oil Seal | 1 | 51873 | 74 | Dowel Pin | 4 | 71068464 |
| 4 | Capscrew | 10 | 50197 | 75 | Capscrew | 8 | 71106736 |
| • 5 | O' Ring | 2 | 51460 | 80 | Drum (8 inch long) | 1 | 20655 |
| 6 | Motor Adapter | 1 | 14227 | | Drum (12 inch long) | | 23759 |
| 14 | Seal Ring | 1 | 10598 | | Drum (16 inch long) | | Contact Factory |
| 15 | Seal Adapter | 1 | 16354 | | Drum (24 inch long) | | 23706 |
| 35 | Shaft | 1 | 11359 | | Drum (30 inch long) | | 24029 |
| 36 | Retainer Ring | 1 | 51871 | * 81 | Wire Rope Anchor 7/16 in. (11 mm) | 1 | 52001 |
| • 37 | Bearing | 1 | 51870 | | Wire Rope Anchor 5/8 in. (16 mm) | 52306 | |
| 38 | Retainer Ring | 1 | 51872 | 82 | Side Rail (8 in. drum) | 1 | 23709-1 |
| 39 | Capscrew | 8 | 52380 | | Side Rail (12 in. drum) | | 23709-2 |
| 40 | Pin | 2 | 50984 | | Side Rail (16 in. drum) | | 23709-3 |
| 41 | Drum Shaft | 1 | 14037 | | Side Rail (24 in. drum) | | 23709-4 |
| 42 | Inboard Upright | 1 | 11376 | | Side Rail (30 in. drum) | | 23709-5 |
| • 43 | Seal | 1 | 51475 | 83 | Side Rail (8 in. drum) | 1 | 23708-1 |
| 45 | Capscrew | 24 | 50973 | | Side Rail (12 in. drum) | | 23708-2 |
| 46 | Lockwasher | 24 | 50181 | | Side Rail (16 in. drum) | | 23708-3 |
| 47 | Gear Carrier | 1 | 15451 | | Side Rail (24 in. drum) | | 23708-4 |
| 48 | Pipe Plug | 2 | 51467 | | Side Rail (30 in. drum) | | 23708-5 |
| • 49 | Bearing | 1 | 51473 | 84 | Outboard Upright | 1 | 10268 |
| 50 | Retainer Ring | 1 | 51479 | 85 | Capscrew | 8 | 50973 |
| Reduction Gear Assy | | 1 | 11409 | • 86 | Bearing | 1 | 51797 |
| Includes items 51 through 75 | | | | 87 | Dowel Pin | 10 | 50984 |
| • 51 | O' Ring | 4 | 52149 | 88 | Name Plate | 1 | 71108849-R |
| 52 | Dowel Pin | 4 | 71068472 | 89 | Drive Screw | 4 | 50915 |
| 53 | Ring Gear | 1 | 71068548 | 93 | Capscrew | 2 | 51485 |
| 54 | Planet Assembly | 1 | 71068555 | 95 | End Cover | 1 | 10266 |
| 55 | Thrust Bearing | 2 | 71068647 | 96 | Washer | 4 | 50200 |
| 63 | Ring Gear | 1 | 71068514 | 97 | Capscrew | 4 | 50829 |
| 66 | Sun Gear | 1 | 71068530 | • 99 | Seal | 1 | 51474 |
| 67 | Planet Assembly | 1 | 71107627 | 501 | Retainer | 1 | 19232 |
| 69 | Sun Gear | 1 | 71107635 | 502 | Seal | 1 | 71054688 |
| 71 | Spacer | 1 | 71068522 | 503 | Spacer | 1 | 14998-7 |
| 73 | Cover | 1 | 71068654 | | | | |

• Recommended spare.

* Wire rope anchors are for use with 6 X 19 or 6 X 37 IWRC right lay construction wire rope only.

MOTOR ASSEMBLY DRAWING

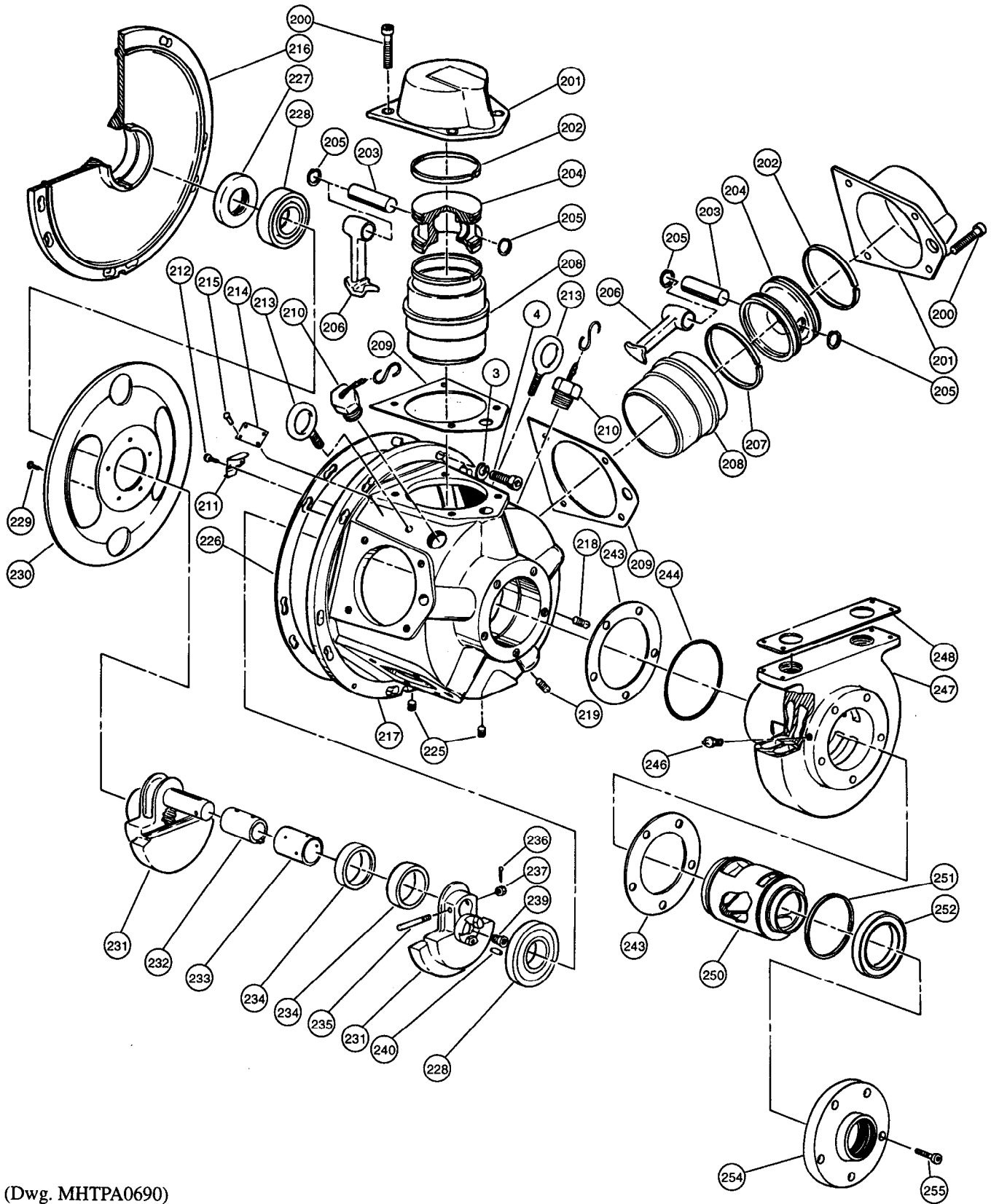

(Dwg. MHTPA0690)

MOTOR ASSEMBLY PARTS LIST

| ITEM NO. | DESCRIPTION OF PART | QTY TOTAL | PART NUMBER | ITEM NO. | DESCRIPTION OF PART | QTY TOTAL | PART NUMBER |
|----------|-----------------------|-----------|----------------|----------|----------------------|-----------|-------------|
| ** | Motor Assembly | 1 | K5B-546L | * 226 | Gasket | 1 | K5B-592 |
| 3 | Lockwasher | 10 | 50201 | * 227 | Oil Seal | 1 | K5B-270 |
| 4 | Capscrew | 10 | 14227 | 228 | Crank Bearing | 2 | K5B-518 |
| 200 | Capscrew | 20 | 52317 | * 229 | Button Head Screw | 5 | * |
| 201 | Cylinder Head | 5 | K5B-H505 | * 230 | Oil Slinger | 1 | * |
| * 202 | Compression Ring | 1 Set | K5B546-KRING | 231 | Crank Assembly | 1 | K5B-A516 |
| 203 | Wrist Pin | 5 | HU-514A | 232 | Sleeve | 1 | K5B-519 |
| * 204 | Piston | 5 | * | 233 | Bushing | 1 | K5B-511 |
| 205 | Retainer Ring | 10 | 902A45-632 | 234 | Connecting Rod Ring | 2 | K5B-510 |
| 206 | Connecting Rod | 5 | K5B-509 | 235 | Lock Pin | 1 | HU-K520 |
| * 207 | Oil Ring | 5 | Order Item 202 | 236 | Cotter Pin | 1 | D02-524 |
| 208 | Cylinder Liner | 5 | K5B-L505-47 | 237 | Pin Nut | 1 | D02-394 |
| * 209 | Head Gasket | 1 Set | K5B-507-5 | 239 | Flat Head Screw | 1 | 139A2A266 |
| 210 | Vent Cap Assembly | 2 | K5B-A303 | 240 | Roll Pin | 1 | WF171-15 |
| 211 | Baffle | 2 | K5B-528 | * 243 | Gasket | 2 | K5B-928 |
| 212 | Screw | 4 | J-376 | * 244 | O' Ring | 1 | 20A11CM248 |
| 213 | Eye Bolt | 2 | KU-888 | 246 | Grease Fitting | 1 | 23-188 |
| 214 | Nameplate | 1 | K5B-301 | 247 | Rotary Valve Housing | 1 | K5B-545 |
| 215 | Drive Screw | 4 | R4K-302-12 | * 248 | Gasket | 1 | K5B-547 |
| 216 | Mounting Flange | 1 | K5B-502 | 250 | Rotary Valve | 1 | K5B-526 |
| 217 | Motor Housing | 1 | K5B-501 | * 251 | Seal Ring | 1 | K5B-607 |
| 218 | Pipe Plug (Oil level) | 1 | ROH-377 | * 252 | Bearing | 1 | K5B-97 |
| 219 | Pipe Plug | 1 | TC-368 | 254 | Exhaust Flange | 1 | K5B-276 |
| 225 | Pipe Plug (Drain) | 2 | GA57-95 | 255 | Capscrew | 5 | 51471 |

* Recommended spare.

* Parts not sold separately. Refer to the "Motor Assembly Kit List."

** Motor Assembly consists of items 200 through 255.

Motor Assembly Kit List:

| ITEM NO. | DESCRIPTION OF PART | QTY TOTAL | PART NUMBER |
|----------|---|-----------|-------------|
| 231 | Crank Assembly (Includes items 206 and 228 through 237) | 1 | K5B-A516 |
| 261 | Piston Assembly (Includes items 202 through 205 and item 207) | 1 | K5B-A513-47 |
| 262 | Cylinder Assembly (Includes items 201 and 208) | 1 | K5B-A505-47 |

DRUM BRAKE ASSEMBLY DRAWING

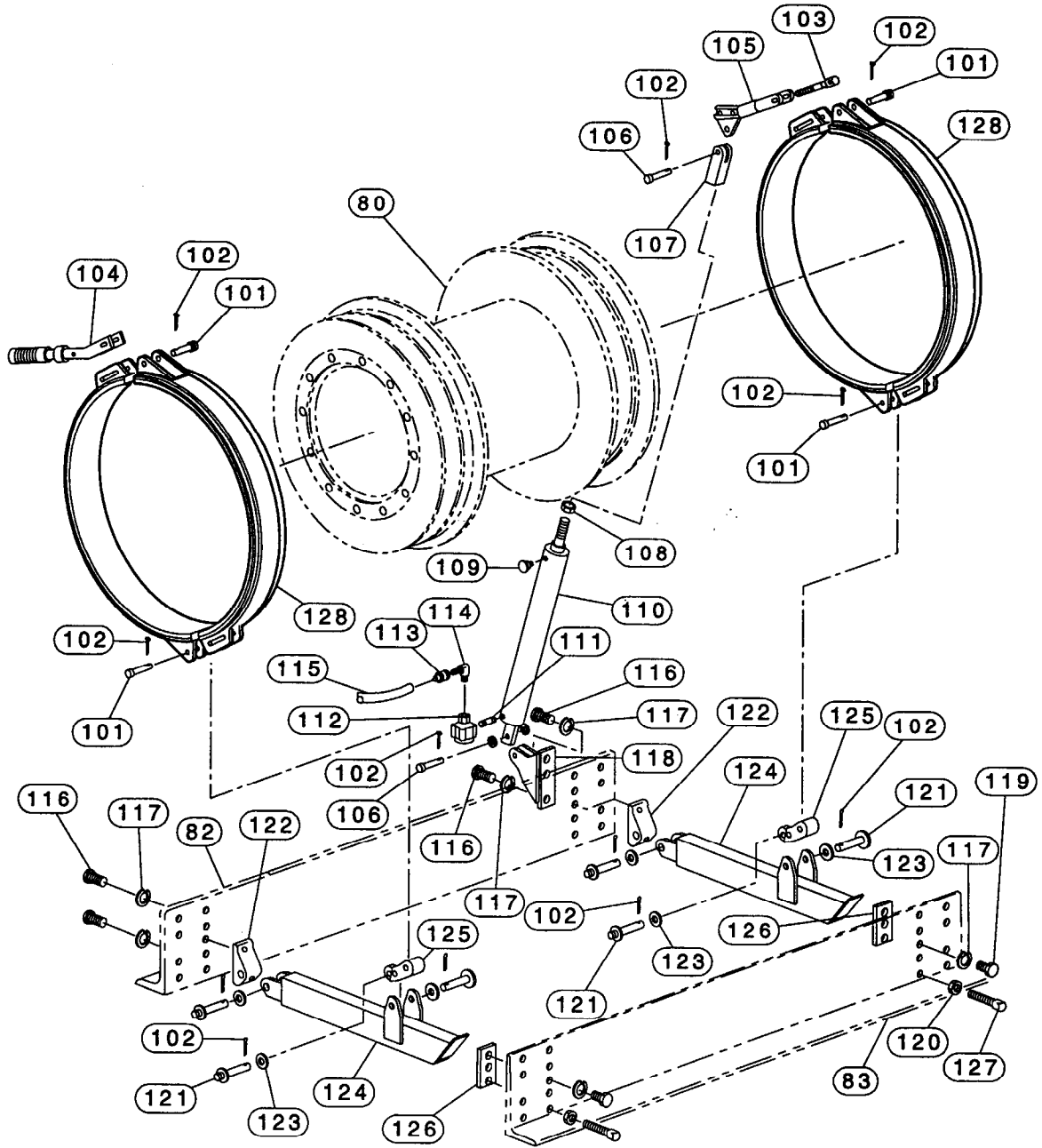

(Dwg. MHTPB0636)

DRUM BRAKE ASSEMBLY PARTS LIST

| ITEM NO. | DESCRIPTION OF PART | QUANTITY TOTAL | PART NUMBER | |
|----------|-----------------------|----------------|--|-----------------|
| | | | MANUAL BRAKE | AUTOMATIC BRAKE |
| 80 | Drum | 1 | Refer to Winch Assembly Drawing and Parts List | |
| 82 | Side Rail | 1 | | |
| 83 | Side Rail | 1 | | |
| 101 | Pin | 4 | 4303-S | |
| 102 | Cotter Pin | See () | 51937 (5) | 51937 (9) |
| 103 | Link Stud | 1 | 2448 | |
| 104 | Handle | 1 | 2329 | --- |
| 105 | Brake Lever | 1 | --- | 11498 |
| 106 | Pin | 2 | --- | 8609 |
| 107 | Clevis | 1 | --- | 6237-2 |
| 108 | Nut | 1 | --- | 50159 |
| 109 | Breather | 1 | --- | 52384 |
| 110 | Cylinder | 1 | --- | 4575-1 |
| 111 | Fitting | 1 | --- | 52006 |
| • 112 | Dump Valve | 1 | --- | 51954 |
| 113 | Fitting, Hose | 2 | --- | 52385 |
| 114 | Fitting, Elbow | 1 | --- | 52330 |
| 115 | Hose | 1 | --- | 50923 |
| 116 | Capscrew | 3 | --- | 50873 |
| 117 | Lockwasher | 6 | 50181 | |
| 118 | Bracket | 1 | --- | 11493 |
| 119 | Capscrew | 3 | 50973 | |
| 120 | Nut | 2 | 50171 | |
| 121 | Pin | 6 | 3704-S | |
| 122 | Pivot Bracket | 2 | 11146 | |
| 123 | Washer | As Req'd | 50890 | |
| 124 | Arm | 2 | 11147 | |
| 125 | Connecting Link | 2 | 11144 | |
| 126 | Stop Plate | 2 | 11145 | |
| 127 | Screw | 2 | 52226 | |
| • 128 | Brake Band | 2 Sets | 10724 (Set) | |
| | Brake Band Lining Kit | 2 Kits | 10724-BLK | |

• Recommended spare.

LIMIT SWITCH ASSEMBLY DRAWING

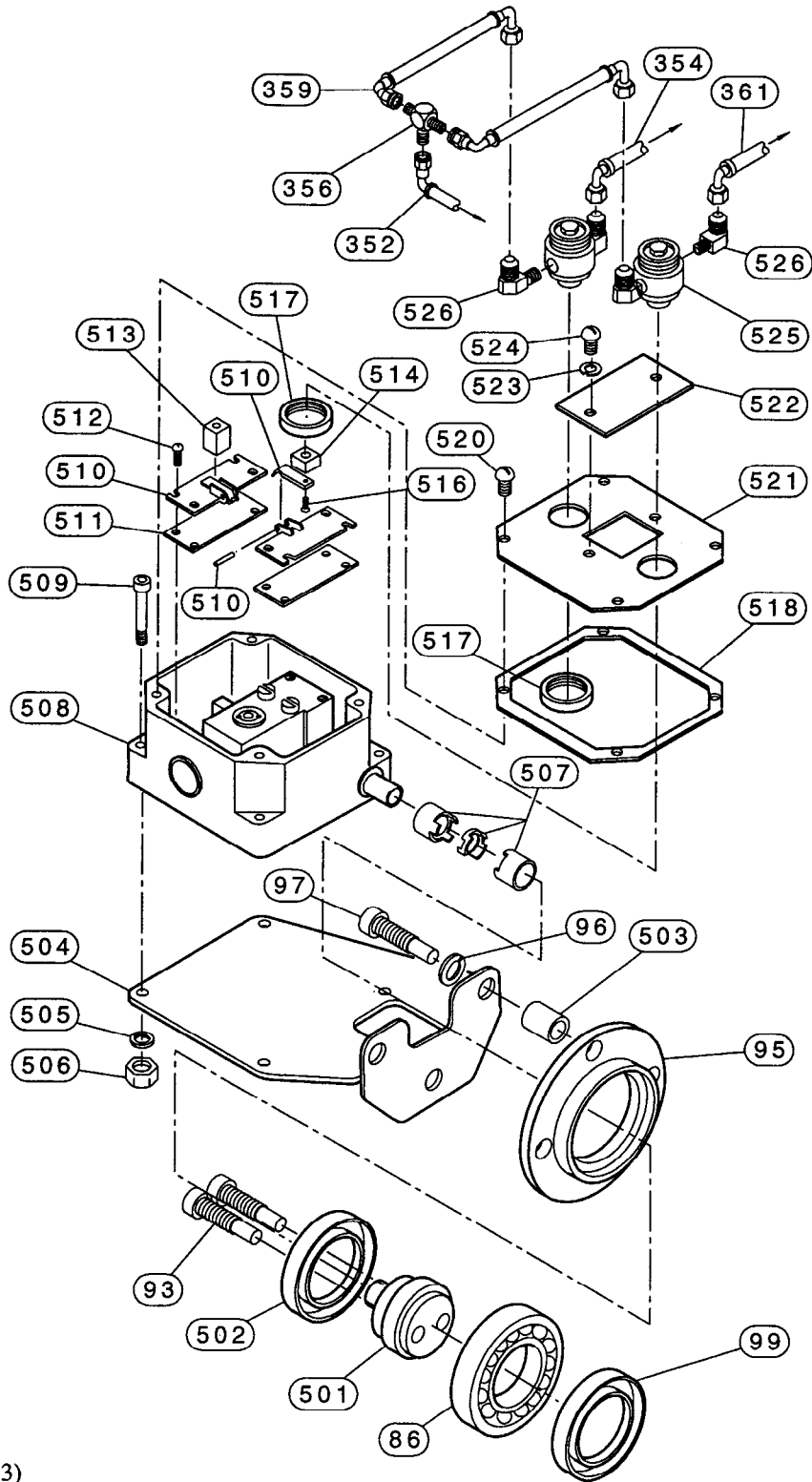

(Dwg. MHTPB0633)

LIMIT SWITCH ASSEMBLY PARTS LIST

| ITEM NO. | DESCRIPTION OF PART | QUANTITY TOTAL | PART NUMBER | |
|----------|--|------------------------|---|-------|
| 86 | Bearing | 2 | 51797 | |
| 93 | Capscrews | 2 | 71030787 | |
| 95 | End Cover | 1 | 19233 | |
| 96 | Lockwasher | 3 | 50200 | |
| 97 | Capscrew | 3 | 51769 | |
| • 99 | Seal | 2 | 51474 | |
| 352 | Hose Assembly | Specify Length in Feet | 50923 | |
| 354 | Hose Assembly | | | |
| 356 | Fitting, Tee | 1 | Contact factory | |
| 359 | Hose Assembly | Specify Length in Feet | 50923 | |
| 361 | Hose Assembly | | | |
| 501 | Retainer | 1 | 19232 | |
| • 502 | Seal | 1 | 71054688 | |
| 503 | Spacer | 3 | 14998-7 | |
| 504 | Bracket, Limit Switch | 1 | 11501 | |
| 505 | Lockwasher | 4 | 52909 | |
| 506 | Nut | 4 | 54142 | |
| 507 | Coupling Assembly | 1 | 52381 | |
| 508 | Limit Switch Assembly (Includes items 510 through 524) | 1 | 19578-1 | |
| 509 | Capscrew | 4 | 54493 | |
| 510 | Lever Assembly | 2 | Order Item 508 Limit Switch Assembly | |
| 511 | Plate | 2 | | |
| 512 | Capscrew | 8 | | |
| 513 | Block, Tall | 1 | | |
| 514 | Block, Short | 1 | | |
| 516 | Capscrew | 2 | | |
| 517 | Locking Ring | 2 | | |
| 518 | Gasket | 1 | | |
| 520 | Capscrew | 4 | | |
| 521 | Cover Plate | 1 | | |
| 522 | Access Plate | 1 | | |
| 523 | Lockwasher | 2 | | |
| 524 | Capscrew | 2 | | |
| 525 | Valve | 4 | | 51756 |
| 526 | Fitting, Elbow | 8 | | 51281 |

• Recommended spares.

DRUM GUARD ASSEMBLY DRAWING AND PARTS LIST (OPTIONAL)

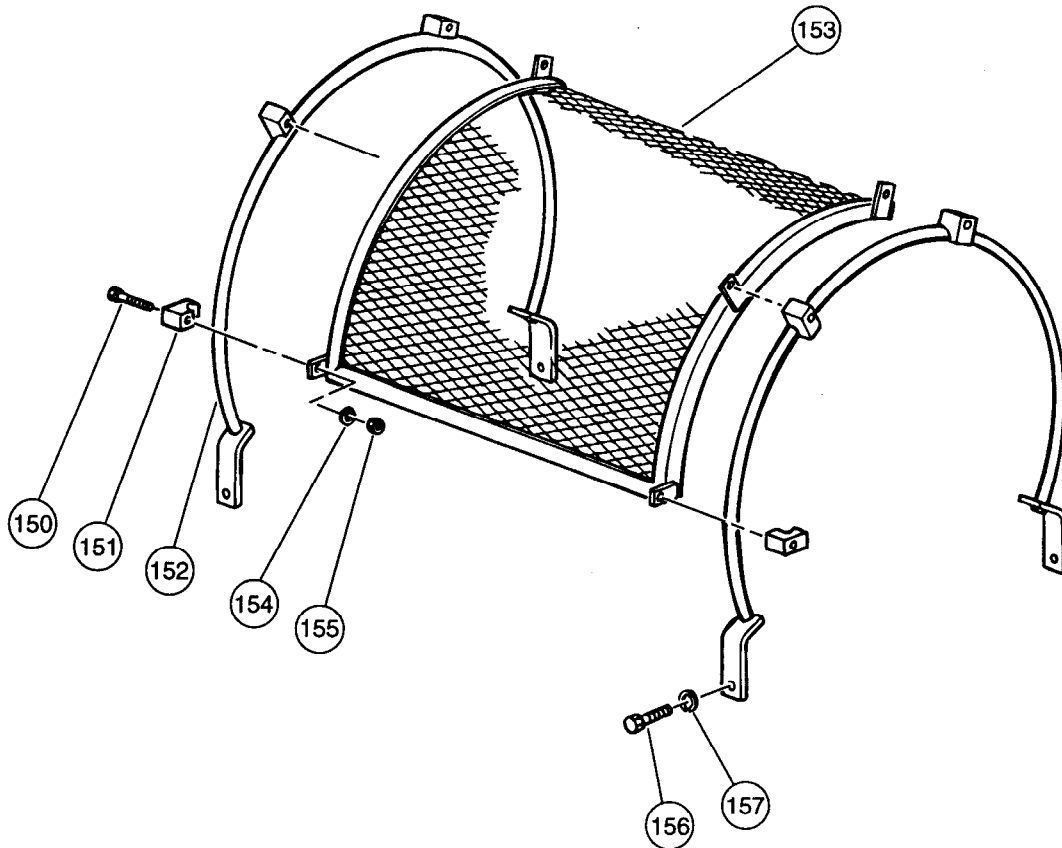

(Dwg. MHTPA0205)

| ITEM NO. | DESCRIPTION OF PART | QUANTITY TOTAL | PART NUMBER |
|----------|---|----------------|-------------|
| * | Drum Guard Assembly (8 inch long drum) | 1 | 11283-1 |
| | Drum Guard Assembly (12 inch long drum) | | 11283-2 |
| | Drum Guard Assembly (16 inch long drum) | | 11283-3 |
| | Drum Guard Assembly (24 inch long drum) | | 11283-5 |
| | Drum Guard Assembly (30 inch long drum) | | 11283-6 |
| 150 | Capscrew | 4 | 71072243 |
| 151 | Clamp | 4 | 10399 |
| 152 | Support | 2 | 10400 |
| 153 | Drum Guard (8 inch long drum) | 1 | 11259-1 |
| | Drum Guard (12 inch long drum) | | 11259-2 |
| | Drum Guard (16 inch long drum) | | 11259-3 |
| | Drum Guard (24 inch long drum) | | 11259-5 |
| | Drum Guard (30 inch long drum) | | 11259-6 |
| 154 | Lockwasher | 4 | 51580 |
| 155 | Nut | 4 | 71061584 |
| 156 | Capscrew | 4 | 53391 |
| 157 | Washer | 4 | 50182 |

* Drum Guard Assemblies include items 150 through 157.

PILOT AIR CONTROL VALVE ASSEMBLY DRAWING AND PARTS LIST

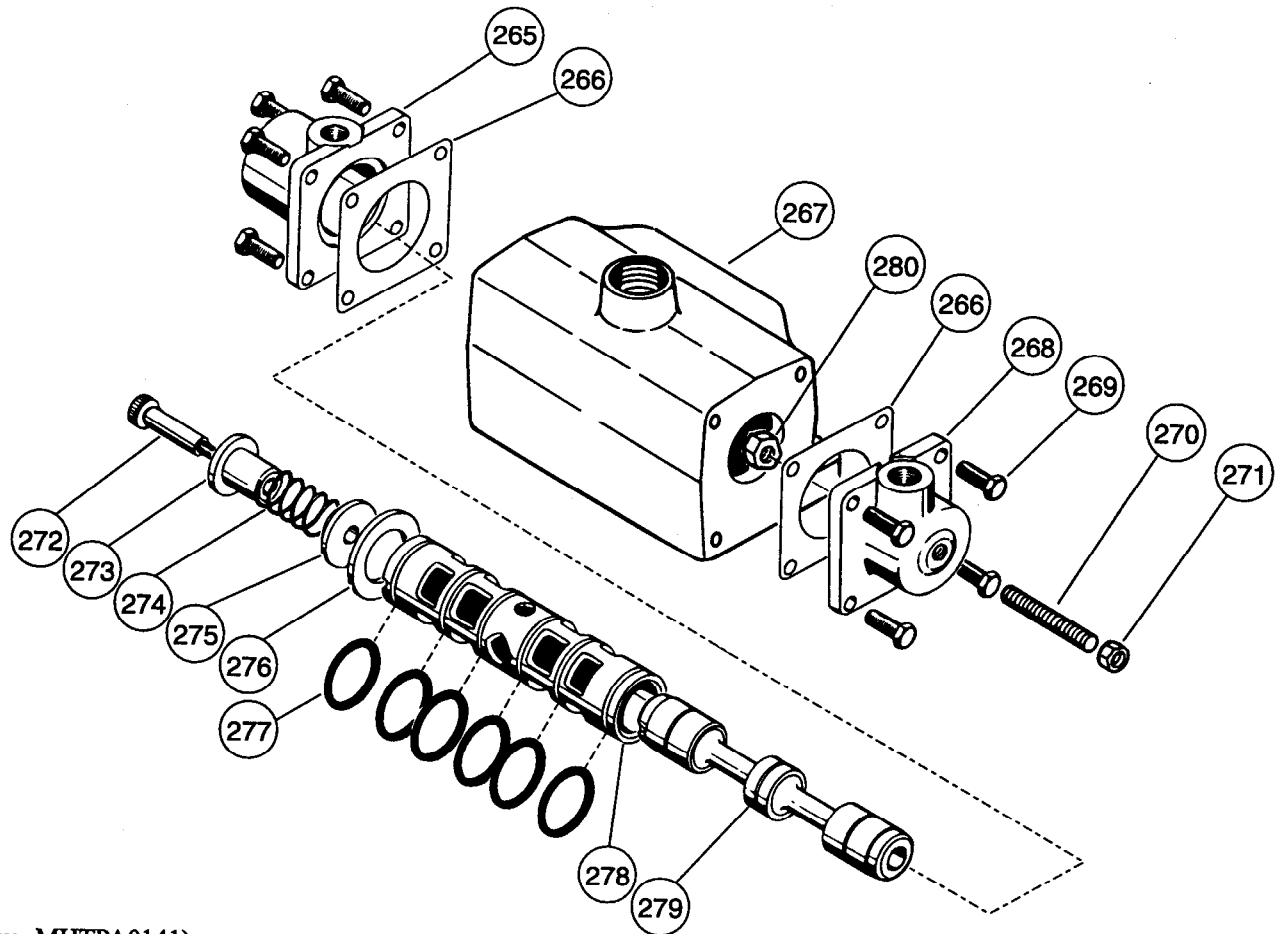

(Dwg. MHTPA0141)

| ITEM NO. | DESCRIPTION OF PART | QTY TOTAL | PART NUMBER |
|----------|--|-----------|-------------------------------------|
| 355 | Valve Assembly (Includes items 265 through 280) | 1 | 20991 |
| 265 | End Cap | 1 | 52241 |
| • 266 | Gasket | 2 | 52457 |
| 267 | Valve Body | 1 | Not sold separately, order item 355 |
| 268 | End Cap (Inlet Side) | 1 | 11778 |
| 269 | Capscrew | 8 | 52234 |
| 270 | Adjusting Screw | 1 | 71083968 |
| 271 | Nut | 1 | 52265 |
| 272 | Shoulder Screw | 1 | 817-002 |
| 273 | Guide | 1 | 52233 |
| 274 | Spring | 1 | 52240 |
| 275 | Washer | 1 | 52239 |
| 276 | Spacer | 1 | 52238 |
| • 277 | O' Ring | 6 | 51632 |
| 278 | Valve Sleeve | 1 | Not sold separately, order item 355 |
| 279 | Valve Spool | 1 | Not sold separately, order item 355 |
| 280 | Stop | 1 | 11777 |

• Recommended spare.

PILOT AIR VALVE PLUMBING ASSEMBLY DRAWING

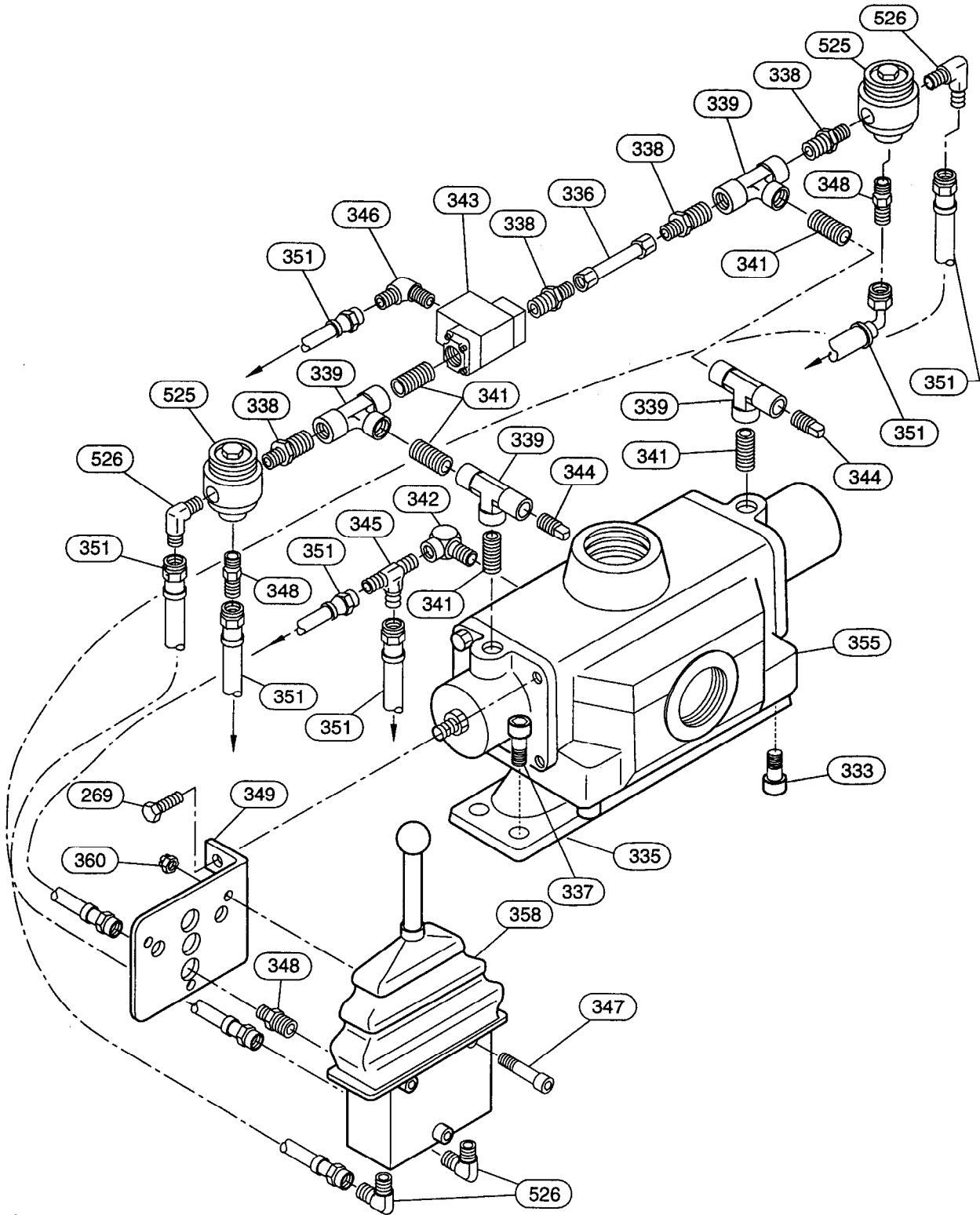

(Dwg. MHTPB0632)

PILOT AIR VALVE PLUMBING ASSEMBLY PARTS LIST

| ITEM NO. | DESCRIPTION OF PART | QTY TOTAL | PART NUMBER |
|----------|-------------------------|------------------------|-------------|
| 269 | Capscrew | 8 | 52234 |
| 333 | Capscrew | 4 | 54681 |
| 335 | Adapter Manifold | 1 | 50893 |
| 336 | Tube Assembly | 1 | |
| 337 | Capscrew | 4 | 50829 |
| 338 | Fitting, Nipple | 4 | 51814 |
| 339 | Fitting, Tee | 4 | 54678 |
| 341 | Fitting, Bushing | 5 | 51034 |
| 342 | Fitting, Elbow | 1 | 71034714 |
| 343 | Valve | 1 | 50277 |
| 344 | Fitting, Plug | 2 | 50822 |
| 345 | Fitting, Tee | 1 | 71063374 |
| 346 | Fitting, Elbow | 1 | 52182 |
| 347 | Capscrew | 3 | 71053763 |
| 348 | Fitting | 3 | 52092 |
| 349 | Bracket | 1 | 20231 |
| 351 | Hose Assembly | Specify Length in Feet | 50923 |
| 355 | Valve Assembly | 1 | 20991 |
| 358 | Throttle Valve Assembly | 1 | 71149389 |
| 360 | Nut | 3 | 54171 |
| 525 | Valve | 4 | 51756 |
| 526 | Fitting, Elbow | 8 | 51281 |

LINE SPEED MONITOR ASSEMBLY DRAWING AND PARTS LIST

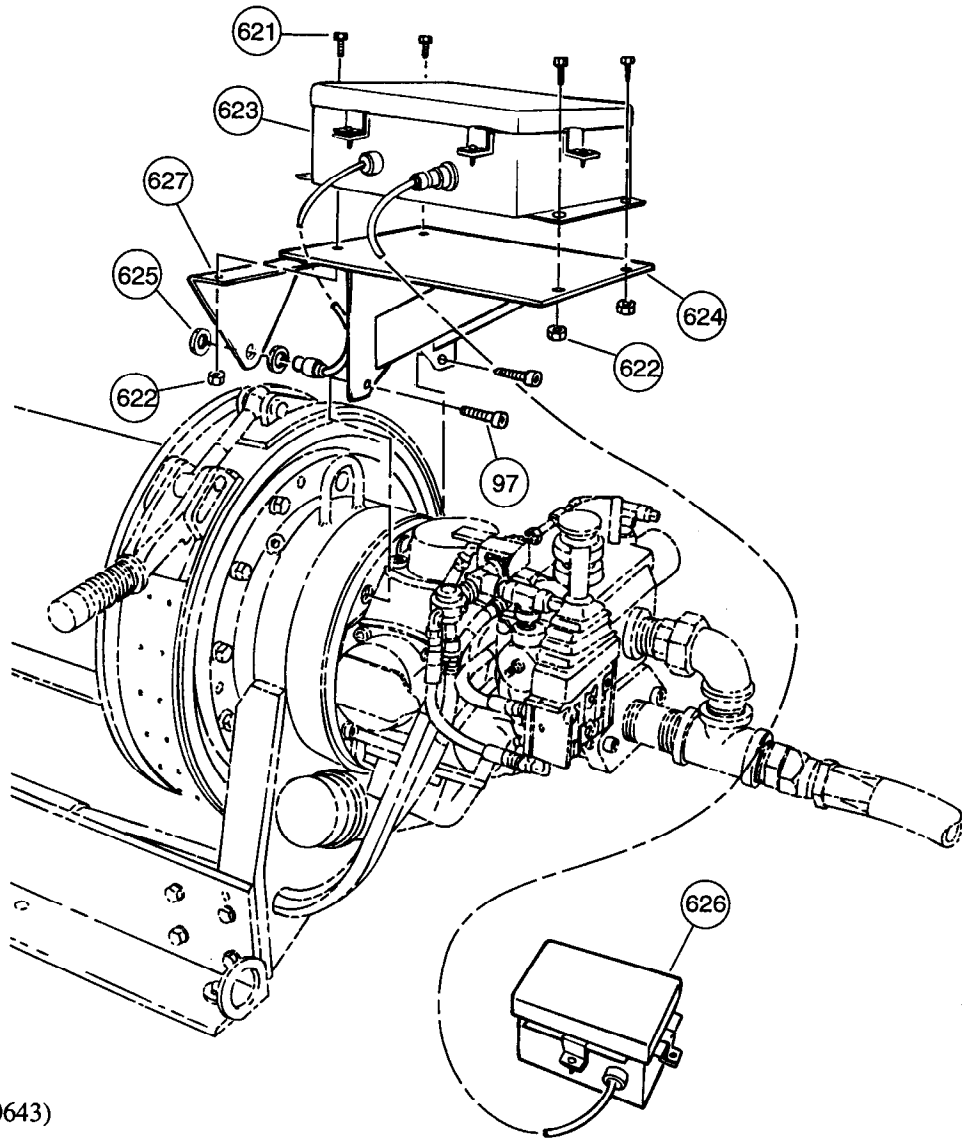

(Dwg. MHTPA0643)

| ITEM NO. | DESCRIPTION OF PART | QUANTITY TOTAL | PART NUMBER |
|----------|-------------------------|----------------|---|
| 97 | Capscrew | 5 | 50829 |
| 621 | Capscrew | 4 | 53374 |
| 622 | Nut | 4 | 53390 |
| 623 | Line Speed Monitor | 1 | LSM1 |
| 624 | Bracket, Monitor | 1 | 23768 |
| 625 | Lock Nut | 2 | Refer to Item 623, provided with sensor |
| 626 | Monitor Battery Charger | 1 | BC01 |
| 627 | Bracket, Sensor | 1 | 23823 |

MUFFLER ASSEMBLY DRAWING AND PARTS LIST

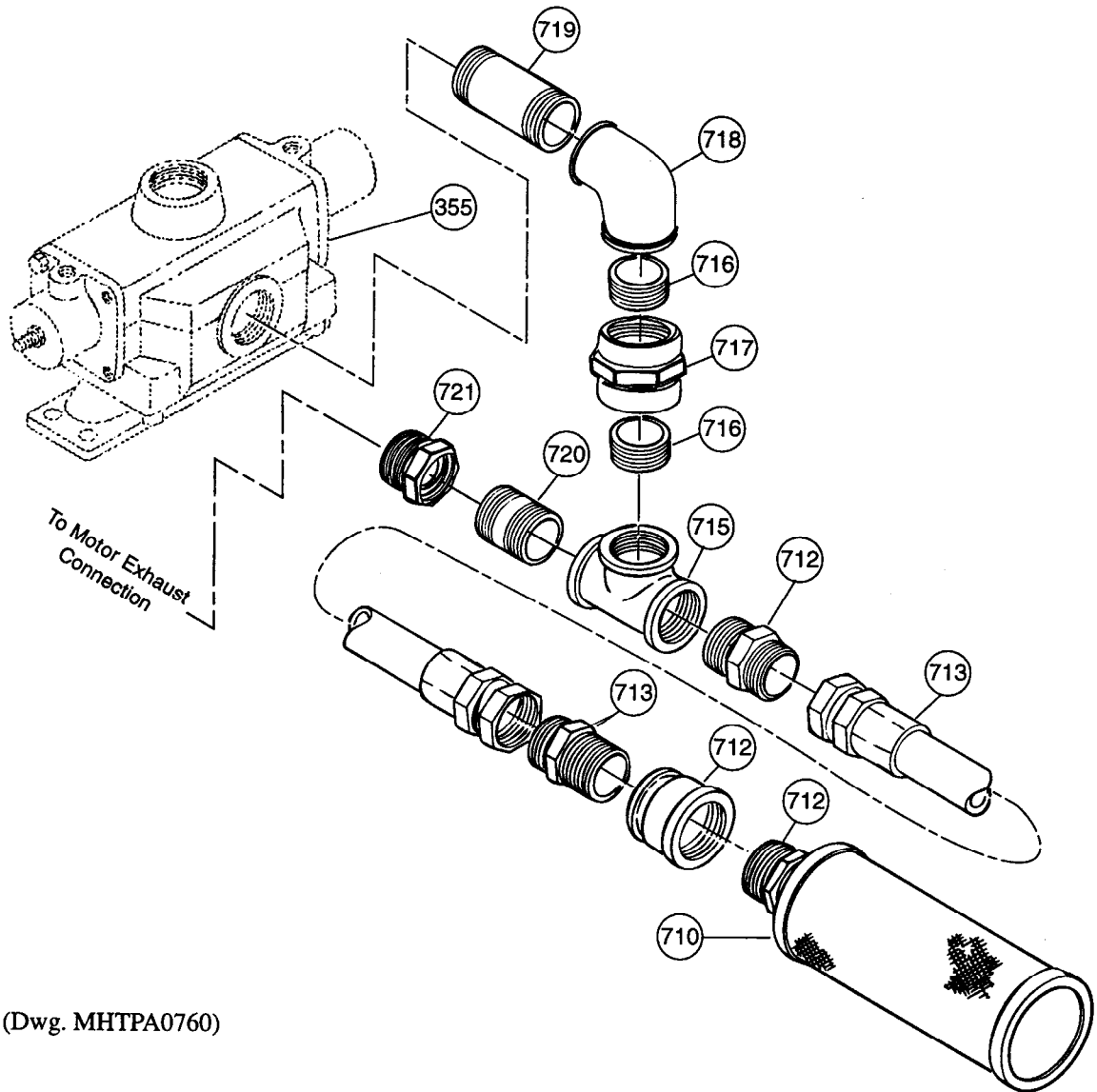

(Dwg. MHTPA0760)

| ITEM NO. | DESCRIPTION OF PART | QUANTITY TOTAL | PART NUMBER |
|----------|---------------------|----------------|-----------------|
| 355 | Valve Assembly | 1 | 20991 |
| 710 | Muffer | 1 | 50594 |
| 711 | Fitting, Pipe | 1 | 71073571 |
| 712 | Fitting | 2 | 71149306 |
| 713 | Hose Assembly | 10 feet | Contact factory |
| 715 | Fitting, Pipe Tee | 1 | 71149504 |
| 716 | Fitting, Pipe | 2 | 51670 |
| 717 | Fitting, Union | 1 | 51708 |
| 718 | Fitting, Elbow | 1 | 51714 |
| 719 | Fitting, Pipe | 1 | 71068852 |
| 720 | Fitting, Pipe | 1 | 71057467 |
| 721 | Fitting, Bushing | 1 | 71057459 |

DISC BRAKE ASSEMBLY DRAWING AND PARTS LIST (OPTIONAL FEATURE)

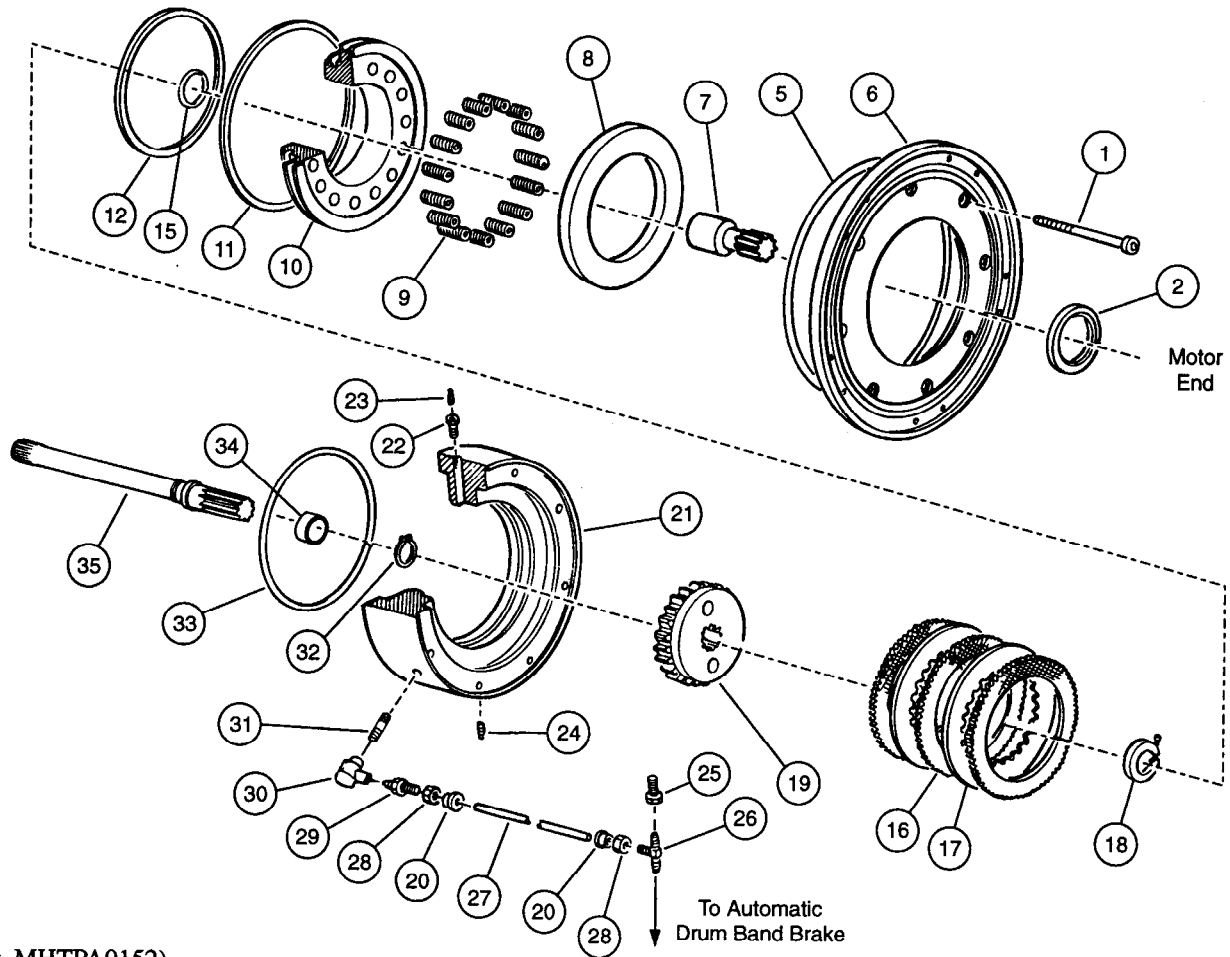

(Dwg. MHTPA0152)

| ITEM NO. | DESCRIPTION OF PART | QTY TOTAL | PART NUMBER | ITEM NO. | DESCRIPTION OF PART | QTY TOTAL | PART NUMBER |
|----------|----------------------|-----------|-------------|----------|---------------------|-----------|-------------|
| 1 | Capscrew | 8 | 51471 | 21 | Brake Housing | 1 | 11322 |
| • 2 | Oil Seal | 1 | 51873 | 22 | Fitting, Reducer | 1 | 51803 |
| • 5 | O Ring | 1 | 51459 | • 23 | Breather | 1 | 51857 |
| 6 | Motor Adapter | 1 | 14227 | 24 | Pipe Plug | 1 | 50801 |
| 7 | Shaft Extender | 1 | 10594 | 25 | Fitting, Reducer | 1 | 52182 |
| 8 | Brake Reaction Plate | 1 | 10597 | 26 | Fitting, Tee | 1 | 52181 |
| • 9 | Spring | 15 | 50751 | 27 | Tubing | 1 | 52520 |
| 10 | Brake Piston | 1 | 15437 | 28 | Nut | 2 | 55013 |
| • 11 | Seal | 1 | 51462 | 29 | Vented Fitting | 1 | 51814 |
| • 12 | Seal | 1 | 51461 | • 30 | Dump Valve | 1 | 50276 |
| 15 | Seal Adapter | 1 | 16354 | 31 | Fitting, Nipple | 1 | 50859 |
| • 16 | Friction Plate | 3 | 50772 | 32 | Retainer Ring | 1 | 50904 |
| • 17 | Drive Plate | 2 | 50773 | • 33 | O Ring | 1 | 51460 |
| 18 | Collar | 1 | 71039333 | • 34 | Spacer | 1 | 18683 |
| 19 | Splined Hub | 1 | 10600 | 35 | Shaft | 1 | 11359 |
| 20 | Sleeve, Fitting | 2 | 55014 | | | | |

• Recommended spare.

WINCH LABEL AND TAG DRAWING AND PARTS LIST

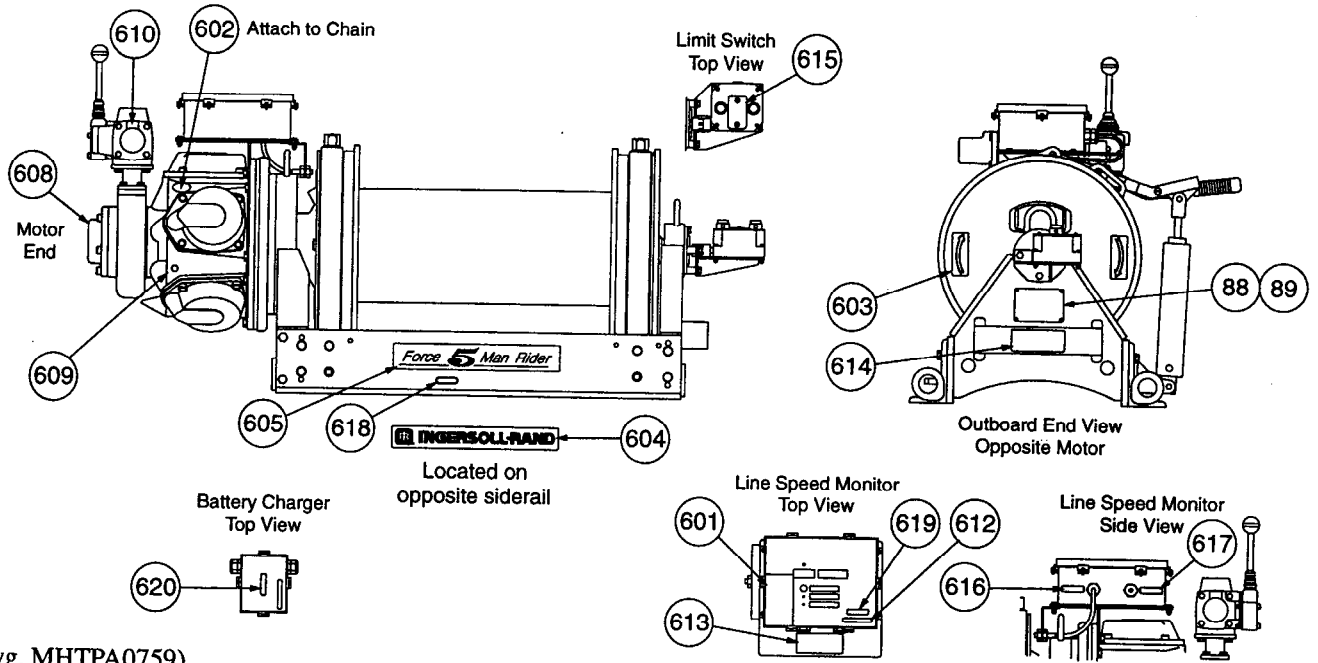

(Dwg. MHTPA0759)

| ITEM NO. | DESCRIPTION OF LABEL | QTY TOTAL | PART NUMBER | ITEM NO. | DESCRIPTION OF LABEL | QTY TOTAL | PART NUMBER |
|----------|----------------------|-----------|-------------|----------|-----------------------|-----------|-------------|
| • 601 | Warning | 1 | 71124895 | 612 | IR Logo (small) | 2 | 71106322 |
| • 602 | Caution Tag | 1 | 71107148 | • 613 | Notice, Man Rider | 1 | 71150023 |
| • 603 | Overwind | 2 | 71109516 | • 614 | Owner's Manual | 1 | 71146278 |
| 604 | IR Siderail Logo | 1 | 71106272 | • 615 | Limit Switch Adjust | 1 | 71149454 |
| 605 | FA Product Label | 1 | 71111785 | 616 | To Sensor Input | 1 | 71149439 |
| • 88 | Nameplate | 1 | 71108849-R | 617 | Battery Charger Input | 1 | 71149421 |
| 89 | Drive Screw | 4 | 50915 | 618 | Ground Connection | 1 | 71149447 |
| 608 | Exhaust | 1 | 71042196 | 619 | Line Speed Monitor | 1 | 71149405 |
| 609 | Oil | 1 | 71043616 | 620 | Battery Charger | 1 | 71149413 |
| 610 | Air Supply | 1 | 71046395 | | | | |

• At a minimum, and to ensure the winch attached labels are in place, replace these labels if they are lost or damaged.

ACCESSORIES PARTS LIST

| DESCRIPTION OF ACCESSORY | ACCESSORY PART NUMBER |
|--------------------------|-----------------------|
| Lubricant | LUBRI-LINK-GREEN |
| Touch-up Paint | FAP-237Y |

PARTS ORDERING INFORMATION

The use of other than **Ingersoll-Rand** Material Handling replacement parts may invalidate the Company's warranty.

For your convenience and future reference it is recommended that the following information be recorded.

Model Number _____

Serial Number _____

Date Purchased _____

When ordering replacement parts, please specify the following:

1. Complete model number and serial number as it appears on the nameplate.
2. Part number(s) and part description as shown in this manual.
3. Quantity required.

The nameplate is located on the winch outboard upright.

| | |
|--|--|
| INGERSOLL-RAND [®] MAN-RIDER [™] | |
| MATERIAL HANDLING AIR WINCH | |
| MODEL NUMBER | _____ |
| SERIAL NUMBER | _____ SERIES _____ |
| MAN-LIFT SWL | _____ lb. at _____ fpm at _____ layer |
| UTILITY SWL | _____ lb. at _____ fpm at _____ layer |
| AIR PRESS | _____ psig AIR FLOW _____ scfm ROPE Dia. _____ in. |
| DRUM SIZE in. | _____ Barrel Dia. _____ Flange Dia. _____ Lgth. |
| Seattle, Washington USA 71108849 | |

NOTICE

- Continuing improvement and advancement of design may cause changes to this equipment which are not included in this manual. Manuals are periodically revised to incorporate changes. Always check the manual edition number on the front cover for the latest issue.
- Sections of this manual may not apply to your winch.
- Using other than genuine **Ingersoll-Rand Material Handling** parts may adversely affect the safe operation of this product.

Return Goods Policy

Ingersoll-Rand will not accept any returned goods for warranty or service work unless prior arrangements have been made and written authorization has been provided from the location where the goods were purchased. Winches which have been modified without **Ingersoll-Rand** approval, mishandled or overloaded will not be repaired or replaced under warranty. A printed copy of the warranty which applies to this winch is provided inside the back cover of this manual.

When the life of the unit has expired, it is recommended that it be disassembled, degreased and parts separated as to materials so that they may be recycled.

For additional information contact:

Ingersoll-Rand Material Handling
P.O. Box 24046
2724 Sixth Avenue South
Seattle, WA 98124-0046 USA
Phone: (206) 624-0466
Fax: (206) 624-6265

or

Ingersoll-Rand Material Handling
Douai Operations
111, avenue Roger Salengro
59450 Sin Le Noble, France
Phone: (33) 27-93-08-08
Fax: (33) 27-93-08-00

HOIST AND WINCH LIMITED WARRANTY

Ingersoll-Rand Company (I-R) warrants to the original user its Hoists and Winches (Products) to be free of defects in material and workmanship for a period of one year from the date of purchase. I-R will repair, without cost, any Product found to be defective, including parts and labor charges, or at its option, will replace such Products or refund the purchase price less a reasonable allowance for depreciation, in exchange for the Product. Repairs or replacements are warranted for the remainder of the original warranty period.

If any Product proves defective within its original one year warranty period, it should be returned to any Authorized Hoist and Winch Service Distributor, transportation prepaid with proof of purchase or warranty card.

This warranty does not apply to Products which I-R has determined to have been misused or abused, improperly maintained by the user, or where the malfunction or defect can be attributed to the use of non-genuine I-R parts.

I-R makes no other warranty, and all implied warranties including any warranty of merchantability or fitness for a particular purpose are limited to the duration of the expressed warranty period as set forth above. I-R's maximum liability is limited to the purchase price of the Product and in no event shall I-R be liable for any consequential, indirect, incidental, or special damages of any nature rising from the sale or use of the Product, whether based on contract, tort, or otherwise.

Note: Some states do not allow limitations on incidental or consequential damages or how long an implied warranty lasts so that the above limitations may not apply to you.

This warranty gives you specific legal rights and you may also have other rights which may vary from state to state.

IMPORTANT NOTICE

It is our policy to promote safe delivery of all orders.

This shipment has been thoroughly checked, packed and inspected before leaving our plant and receipt for it in good condition has been received from the carrier. Any loss or damage which occurs to this shipment while enroute is not due to any action or conduct of the manufacturer.

Visible Loss or Damage

If any of the goods called for on the bill of lading or express receipt are damaged or the quantity is short, do not accept them until the freight or express agent makes an appropriate notation on your freight bill or express receipt.

Concealed Loss or Damage

When a shipment has been delivered to you in apparent good condition, but upon opening the

crate or container, loss or damage has taken place while in transit, notify the carrier's agent immediately.

Damage Claims

You must file claims for damage with the carrier. It is the transportation company's responsibility to reimburse you for repair or replacement of goods damaged in shipment. Claims for loss or damage in shipment must not be deducted from the Ingersoll-Rand invoice, nor should payment of Ingersoll-Rand invoice be withheld awaiting adjustment of such claims as the carrier guarantees safe delivery.

You may return products damaged in shipment to us for repair, which services will be for your account and form your basis for claim against the carrier.

United States Office Locations

For Order Entry and Order Status

**Ingersoll-Rand
Distribution Center**
P.O. Box 618
510 Hester Drive
White House, TN 37188
Phone: (615) 672-0321
Fax: (615) 672-0801

For Technical Support

**Ingersoll-Rand
Material Handling**
P.O. Box 24046
2724 Sixth Avenue South
Seattle, WA 98124-0046
Phone: (206) 624-0466
Fax: (206) 624-6265

Regional Sales Offices

Chicago, IL
888 Industrial Drive
Elmhurst, IL 60126
Phone: (708) 530-3800
Fax: (708) 530-3891

Detroit, MI
23192 Commerce Drive
Farmington Hills, MI 48335
Phone: (810) 476-6677
Fax: (810) 476-6670

Houston, TX
Suite 150
2500 East T.C. Jester
Houston, TX 77008
Phone: (713) 864-3700
Fax: (713) 864-2244

Los Angeles, CA
11909 E. Telegraph Road
Santa Fe Springs, CA 90670
Phone: (310) 948-4189
Fax: (310) 948-1828

Philadelphia, PA
900 E. 8th Ave., Suite 103
King of Prussia, PA 19406
Phone: (610) 337-5930
Fax: (610) 337-5912

International Office Locations

Offices and distributors in principal cities throughout the world. Contact the nearest **Ingersoll-Rand** office for the name and address of the distributor in your country or write/fax to:

**Ingersoll-Rand
Material Handling**
P.O. Box 24046
2724 Sixth Avenue South
Seattle, WA 98124-0046
USA
Phone: (206) 624-0466
Fax: (206) 624-6265

**Canada
National Sales Office
Regional Warehouse
Toronto, Ontario**
51 Worcester Road
Rexdale, Ontario
M9W 4K2
Phone: (416) 675-5611
Fax: (416) 675-6920
Order Desk
Fax: (416) 674-6549

Regional Sales Offices

Calgary, Alberta
44 Harley Road S.E.
Calgary, Alberta
T2V 3K3
Phone: (403) 252-4180
Fax: (403) 252-4462

Edmonton, Alberta
1430 Weber Center
5555 Calgary Trail N.W.
Edmonton, Alberta
T6H 5G8
Phone: (403) 438-5039
Fax: (403) 437-3145

Montreal, Quebec
3501 St. Charles Blvd.
Kirkland, Quebec
H9H 4S3
Phone: (514) 695-9040
Fax: (514) 695-0963

British Columbia
201-6351 Westminster Hwy
Richmond, B. C.
V7C 5C7
Phone: (604) 278-0459
Fax: (604) 278-1254

**Latin America Operations
Ingersoll-Rand
Production Equipment
Group**
730 N.W. 107 Avenue
Suite 300, Miami, FL
33172-3107
Phone: (305) 559-0500
Fax: (305) 559-7505

**Europe, Middle East and
Africa
Ingersoll-Rand
Material Handling
Douai Operations**
111, avenue Roger Salengro
59450 Sin Le Noble, France
Phone: (33) 27-93-08-08
Fax: (33) 27-93-08-00

**Asia Pacific Operations
Ingersoll-Rand (Japan) Ltd.**
Shin-Yokohama Square Bldg.
(5th Floor)
2-3-12 Shin-Yokohama,
Kouhoku-Ku
Yokohama-shi, Kanagawa
Pref. 222 Japan
Phone: 81-45-476-7800
Fax: 81-45-476-7806

**Russia
Ingersoll-Rand Company**
World Trade Center
Office 1101
Krasnopresnenskaya Nab. 12
Moscow, Russia 123610