

IMPORTANT INFORMATION:

- A copy of our “Safe Operating Practices” Manuals are always available free of charge either by downloading it from our Technical Publications website @ www.airwinch.com or by contacting the Factory at (800) 866-5457 for North America and (206) 624-0466 for International. The Safe Operating Practices manual must be read prior to anyone operating a **Ingersoll-Rand** winch or hoist. The manual form numbers are as follows:

“Safe Operating Practices Non-Man Rider™ Winches” Manual, Form No. MHD56250

“Safe Operating Practices for Man Rider™ Winches” Manual, Form No. MHD56251

“Safe Operating Practices for Pneumatic, Hydraulic and Electric Hoists” Manual, Form No. MHD56295

- Available winch options may require additional supplements to the basic winch manual.
- For Man Rider™ winches ensure a copy of the Man Rider™ supplement is made available to the operator prior to winch operation.

Winch Man Rider™ Supplements:

Model:	Publication No.
FA2, FA2.5, FH2, FH2.5	MHD56046
FA5	MHD56042 and MHD56220
FA10	MHD56252
FA2.5A	MHD56236
FA2B and HU40A	MHD56207
FH10MR	MHD56212
Fulcrum Electric	MHD56277
LS500HLP/ LS1000HLP	SAM0004

Model:	Publication No.
LS500RLP	SAM0011
LS1000RLP	SAM0012
LS150RLP	SAM0082
LS150RLP/500/ 1000	SAM0115
LS150RLP and LS150PLP-PH	SAM0120
LS500RLP-E	SAM0122
LS150RLP- DP5M-F	SAM0184
LS150HLP	SAM0222

- We strongly recommend that ALL maintenance on **Ingersoll-Rand** equipment be carried out by personnel certified by **Ingersoll-Rand**, or by **Ingersoll-Rand** Authorized Service Centers.
- Contact the Factory if in doubt about installation, operation, inspection and maintenance instructions.
- Use only Genuine **Ingersoll-Rand** parts when maintaining or repairing a winch, hoist or any component of a winch or hoist.
- ANSI / ASME recommends that a winch or hoist (or any components of a winch or hoist) that has been repaired be tested prior to being placed into service:
 - * **Winches** - ANSI / ASME B30.7 (BASE MOUNTED DRUM HOISTS) Refer to section 7.2.2 - Testing.
 - * **Hoists** - ANSI / ASME B30.16 (OVERHEAD HOISTS - UNDERHUNG) Refer to section 16.2.2 - Testing.

PARTS, OPERATION AND MAINTENANCE MANUAL

force **5**TM **AIR WINCHES**

MODEL

FA5MRA MANRIDER* WINCH

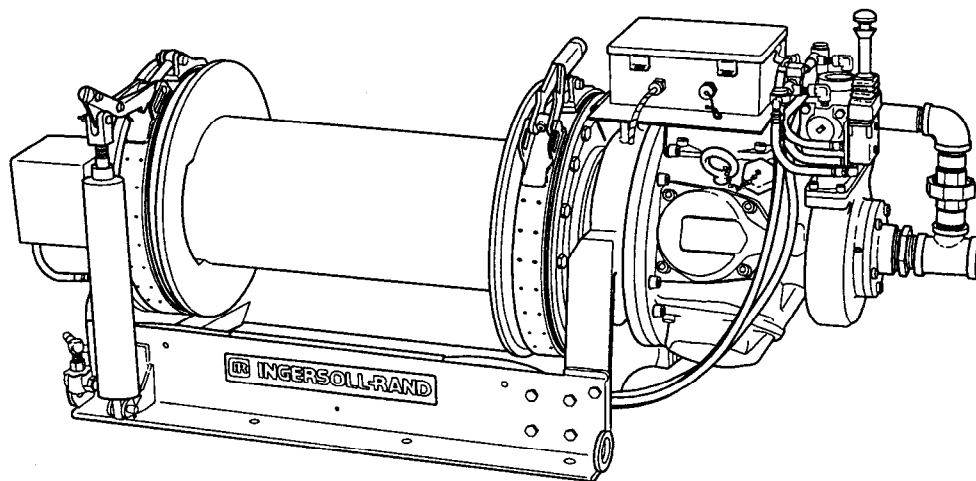

* Instructions contained in this manual apply only to winches designed by Ingersoll-Rand, and that are identified for personnel lifting by a permanent nameplate attached to the winch at the factory.

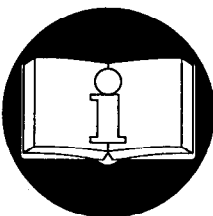

READ THIS MANUAL BEFORE USING THESE PRODUCTS. This manual contains important safety, installation, operation and maintenance information. Make this manual available to all persons responsible for the operation, installation and maintenance of these products.

The winch is only part of the Personnel Lifting System. For information defining the Personnel Lifting System requirements read ANSI A10.22 and all associated manufacturers' component literature. A copy of ANSI A10.22-1990 is provided with this product.

Always operate, inspect and maintain this winch in accordance with American National Standards Institute Safety Codes (ANSI A10.22 and ASME B30.7) and all other applicable local, state and federal safety codes and regulations.

SAFETY INFORMATION

This manual provides important information for all personnel involved with the safe installation, operation and proper maintenance of this product. Even if you feel you are familiar with this or similar equipment, you should read this manual before operating the product.

Danger, Warning, Caution and Notice

Throughout this manual there are steps and procedures which, if not followed, may result in an injury. The following signal words are used to identify the level of potential hazard.

⚠ DANGER Danger is used to indicate the presence of a hazard which will cause severe injury, death, or substantial property damage if the warning is ignored.

⚠ WARNING Warning is used to indicate the presence of a hazard which can cause severe injury, death, or substantial property damage if the warning is ignored.

⚠ CAUTION Caution is used to indicate the presence of a hazard which will or can cause injury or property damage if the warning is ignored.

NOTICE Notice is used to notify people of installation, operation, or maintenance information which is important but not hazard-related.

Safety Summary

⚠ WARNING

- This winch was designed to meet ANSI A10.22-1990 which limits its use as part of a system for personnel lifting. There are other components required to complete the system. It is the users responsibility to supply all other components necessary to properly complete the lifting system in accordance with the regulations that pertain to the lifting application.
- It is the owner's and user's responsibility to check and to conform to all regulations (local, state, federal and country) that may apply to the use of a winch or winch system for lifting and lowering people before using a Man-Rider® winch for personnel movement.
- The supporting structures and load-attaching devices used in conjunction with this winch must provide an adequate safety factor to handle the rated load, plus the weight of the winch and attached equipment. This is the customer's responsibility. If in doubt, consult a registered structural engineer.

Ingersoll-Rand Man-Rider® winches are designed and manufactured to meet or exceed standards and specifications established for base mounted drum hoists as defined by ASME B30.7 and for the purpose of personnel handling as defined by ANSI A10.22 - 1990.

In furnishing customers **Man-Rider®** winches, **Ingersoll-Rand** does not warrant the suitability of these winches for any particular use. It is the owner's and user's responsibility to determine the suitability of this winch for a particular application.

Ingersoll-Rand Man-Rider® winches manufactured to ANSI A10.22 standards are designed as a component in the Personnel Lifting System. **Ingersoll-Rand** approval for use of this winch in **Man-Rider®** applications automatically terminates for any of the following reasons:

1. Winch is not installed in an approved personnel lifting system.
2. Winch is not properly maintained in a safe working condition, with all parts intact and properly adjusted.
3. Winch is used in applications not approved by codes and regulations, or application is inconsistent with manufacturer's operation and maintenance manual.
4. More than one winch is used to attach to a common load.
5. Winch design or functions are altered or changed in any manner from the purchased original without prior approval by **Ingersoll-Rand**.

This manual has been produced by **Ingersoll-Rand** to provide company personnel, dealers, mechanics and operators with the information required to install, operate, and maintain the products described herein.

It is extremely important that mechanics and operators be familiar with the servicing procedures of these products, or like or similar products, and are physically capable of conducting the procedures. These personnel shall have a general working knowledge that includes:

1. Proper and safe use and application of common mechanics' hand tools as well as special **Ingersoll-Rand** or recommended tools.
2. Safety procedures, precautions and work habits established by accepted industry standards.

Ingersoll-Rand can not know of, nor provide all the procedures by which product operations or repairs may be conducted and the hazards and/or results of each method. If operation or maintenance procedures not specifically recommended by the manufacturer are conducted, it must be ensured that product safety is not endangered by the actions taken. If unsure of an operation or maintenance procedure or step, personnel should place the winch in a safe condition and contact supervisors and/or the factory for technical assistance.

WINCH SAFE OPERATING INSTRUCTIONS

The following warnings and operating instructions have been adapted in part from American National (Safety) Standards ASME B30.7 and ANSI A10.22, and are intended to avoid unsafe operating practices which might lead to injury or property damage.

Ingersoll-Rand recognizes that most companies who use winches have a safety program in force at their facility. In the event that a conflict exists between a rule set forth in this publication and a similar rule already set by an individual company, the more stringent of the two should take precedence.

WARNING

• **Failure to follow these operating instructions may result in death or property damage. Ingersoll-Rand assumes no liability for any loss or damage resulting from operation of Man-Rider® winches if these operating instructions are not followed.**

Safe Operating Instructions are provided to make an operator aware of dangerous practices to avoid and are not necessarily limited to the following list. Refer to specific sections in the manual for additional safety information.

1. Winch operator must be in vocal contact with personnel being lifted (lowered) from transfer point to landing area.
2. Personnel supervising, operating the winch and personnel being transferred are to be instructed in system operation and safety prior to personnel lifting. Only operate a winch if you are physically fit to do so.
3. Use of a winch to transport personnel (lifting and/or lowering) should only take place when other means of accomplishing this work are not practical.
4. When a “**DO NOT OPERATE**” sign is placed on the winch, or winch controls, do not operate the winch until the sign has been removed by designated personnel.
5. Never lift a load greater than the rated capacity of the winch. Refer to “**SPECIFICATIONS**” section for applicable utility and **ManRider®** capacity ratings.
6. Prior to use, inspect and test the personnel lifting system to the requirements of ANSI A10.22 Section 13 (Inspection and Tests). The winch operator shall be instructed in the operation of this winch and the personnel lifting system per ANSI A10.22 Section 5 (Operation of Hoist).
Winch only: Refer to ‘Testing’ procedures in the “**WINCH INSPECTION**” section of this manual for winch information.
7. Installation of the winch must be specially arranged and approved for personnel handling as a component in a Personal Handling System as described and defined in ANSI A10.22. Refer to the “**INSTALLATION**” section. All bolts and foundations for winch attachment must have a higher load carrying capacity rating than the maximum capacity of the winch.
8. Do not operate a damaged winch.
9. Do not operate a winch that has not been properly maintained or equipped.
10. Do not operate winch with any personnel near the line of force or capable of coming into contact with moving parts.
11. Labels and warning notices must remain permanently posted, and be clearly visible on the winch.
12. Ease the slack out of the wire rope when starting a lift. Do not jerk the load.
13. Never leave a suspended load unattended.
14. Wire rope must spool off drum from the top away from the operator (overwind). The direction of lift is counterclockwise when viewed from the motor end of the winch.
15. Make sure the wire rope is properly anchored to the winch drum.
16. Pay attention to the load at all times when operating the winch.
17. Never use the winch wire rope as a sling.
18. Do not leave a load suspended when winch is not in use.
19. Ensure muffler is positioned at the point furthest away from winch operator.
20. Do not use limit switch settings to regulate the winch stopping points. Limit switches are designed as a backup to operator accidental over travel only.
21. Ensure the end of the wire rope is weighted to prevent line run.

WINCH WARNING LABELS

Each unit is shipped from the factory with the warning label shown. If the label is not attached to your unit, order a new label and install. See the parts list for the part number. Label is shown smaller than actual size.

⚠ WARNING

Failure to follow these warnings can result in severe injury, death or property damage:

- Do not operate this winch before reading operation and maintenance manual. 
- Do not lift loads over people.
- Do not lift more than rated load as specified on name plate.
- Do not allow less than four wraps of wire rope to remain on drum at all times.
- Do not operate a damaged or malfunctioning winch.
- Do not remove or obscure warning labels.

P/N 71124895
for Man Rider winches **INGERSOLL-RAND.**
MATERIAL HANDLING

WINCH SPECIFICATIONS

Description

The FA5MRA winch are air powered, planetary geared units designed for lifting and pulling applications. When incorporated into an approved personnel lifting system and operated as instructed by the procedures defined in this manual as well as the requirements of ANSI A10.22-1990, the FA5MRA winch can be used to transfer personnel. These winches are provided with a spring actuated, air released drum band brake and a manually operated drum band brake. The spring actuated drum band brake automatically applies when the motor throttle control lever is returned to the neutral position, when the pendant (if equipped) control button is released, and if there is a loss of air pressure.

The output from the externally mounted air piston motor is transmitted through a coupling and shaft to the planetary reduction gear assembly.

The output from the planetary reduction gear assembly is connected to the wire rope drum through the output shaft. The line speed monitor and overspeed alarm provide the operator with winch operating line speed rate and indication of overspeed at the winch, and indication of overspeed on the pendant (if equipped).

The winch mounted throttle control lever must be lifted before operating in either the pay out or haul in directions and will return to the neutral position when released.

The limit switch assembly prevents winch operation beyond established haul in and pay out setpoints. The setpoints are adjustable.

General Specifications		Model FA5MRA			
		Utility Rating *		ANSI ManRider® Rating *	
Air System	Rated Operating Pressure	90 psig (6.3 bar)			
	Consumption Volume (at rated pressure)	700 scfm	20 cu.m/min	700 scfm	20 cu.m/min
Performance (at rated pressure / volume)	Rated Full Drum Line Pull *	7,040 lbs	3,200 kgs	4,400 lbs	2,000 kgs
	Line Speed - 3rd Layer (UP)	55 fpm	17 m/min	64 fpm	19.5 m/min
	Line Speed - 3rd Layer (DOWN)	78 fpm	24 m/min	69 fpm	21 m/min
	Max Stall Pull - 1st Layer	24,000 lbs	10,900 kgs	24,000 lbs	10,900 kgs
	FA5MRA Net Weight	2,190 lbs	995 kgs	2,190 lbs	995 kgs
Air Motor Pipe Inlet Size		1-1/4 inch	32 mm	1-1/4 inch	32 mm
Minimum Air System Hose Size		1-1/2 inch	38 mm	1-1/2 inch	38 mm
Drum Wire Rope Storage Capacity ** (feet / metres)	Drum Length (inches)	Wire Rope Diameter			
		5/8 inch		16 mm	
	8	341 feet		104 metres	
	12	512 feet		156 metres	
	16	683 feet		208 metres	
	24	1024 feet		312 metres	
	30	1280 feet		390 metres	
	36	1536 feet		468 metres	

* FA5 Utility rating of 7,040 lbs. (3,200 kg) is based on requirements of ASME B30.7 (5:1 design factor with 5/8 inch (16 mm) wire rope.)

FA5 ManRider® rating of 4,400 lbs. (2,000 kg) is based on requirements of ANSI A10.22 (24:1 drum to wire rope ratio) and factory recommended 8:1 safety design factor of 8:1 using 5/8 inch (16 mm) wire rope.)

** FA5 ManRider® wire rope storage is based on a winch with a 27 inch (686 mm) diameter drum flange and on ANSI A10.22 standards which require the top layer to be at least 2 inches (51 mm) below the drum flange diameter. Capacities shown may vary from those published elsewhere.

Model Code Explanation

Example: FA5MRA24MA1G

FA5 MRA 24 M A 1 G

Series (Capacity):

Model FA5 Personnel Lifting - 2 metric tons / 4,400 lbs.
 Utility Lifting - 3.2 metric tons / 7,100 lbs.

Designation:

* MRA = Man Rider® ANSI A10.22-1990

Drum Length (Distance between drum flanges):

- 8 = 8 inch (203 mm)
- 12 = 12 inch (305 mm)
- 16 = 16 inch (406 mm)
- 20 = 20 inch (508 mm)
- 24 = 24 inch (610 mm) [Standard]
- 30 = 30 inch (762 mm)
- 36 = 36 inch (914 mm)

Brake:

- M = Manual Drum Brake (Standard)
- A = Automatic Drum Brake (Standard)
- K = Automatic Disc Brake

Control:

- 1 = Winch mounted lever throttle (Standard)
- 3XX = Remote pilot pendant throttle with warning light (XX = Specify hose length (feet)) **
- 5XXX = Remote electric throttle control (XXX = Specify hose length (feet)) **

Options:

- Z = Sand blast and Carbozinc primer only
- P = Marine 812 top coat
- G = Drum Guard
- 7 = Drum Grooving (Number = wire rope size in sixteenths, e.g. 7/16 inch)

- * Standard Features:
 - (1) Line Speed Monitor.
 - (2) Adjustable upper and lower rotary limit switches.
 - (3) Piped away exhaust with muffler and 10 feet (3 metres) of exhaust hose.
 - (4) Copy of Operation and Maintenance Manual and ANSI A10.22 Standard supplied in container attached to winch.
 - (5) Manual and Automatic Drum Band Brake.

** Remote pendants are provided with standard length 10 feet (3 metres) hose. Specify hose lengths greater than 10 feet. For lengths greater than 50 ft. (15 metres) with the Remote Pilot Pendant Throttle or Remote Pilot Electric Throttles contact Technical Sales for control acceptability. Metric lengths for reference only, order lengths required to be in feet.

Note: FA5MRA winches are shipped with a muffler, 10 feet (3 m) of exhaust hose and the necessary assembly attachments to install the muffler at a distance far enough away from the operator to ensure noise level exposure of less than 90 dBA over an eight hour period (Time Weighted Average (TWA)). The recommended distance is based on noise levels recorded during factory testing. Refer to the "INSTALLATION" section for additional information.

WINCH INSTALLATION

Prior to installing the winch, carefully inspect it for possible shipping damage. Winches are supplied fully lubricated from the factory. Before operation check oil levels and adjust as necessary. Use the proper type of oil as recommended in the "LUBRICATION" section.

⚠ CAUTION

• Owners and users are advised to examine specific, local or other regulations, including ANSI A10.22, ASME B30.7 and/or OSHA Regulations which may apply to a particular type of use of this product before installing or putting winch to use.

Mounting

Care must be taken when moving, positioning or mounting the winch. In most cases, lifting lugs have been provided to assist in handling the winch. If the lug locations are improper for your specific installation, great care should be taken to ensure that the winch, when lifted, will be properly balanced. Determine the weight of your winch by referring to the "SPECIFICATIONS" section. Lift the winch 3 to 4 inches (75 to 100 mm) off the ground. Verify winch is balanced and secure before continuing lift.

⚠ CAUTION

• Care must be taken when lifting the winch. Determine winch center of gravity and arrange lifting straps to raise the winch evenly.
• If the winch is mounted to a portable foundation, always attach the lifting straps or cables to the foundation structure when lifting and supporting the winch assembly.

⚠ WARNING

• Install the wire rope to come off the drum for overwind operation ONLY. Failure to correctly spool the wire rope will result in falling load, which can cause severe injury, death and property damage. Refer to Dwg. MHTPA0661.

1. Ensure the winch is positioned in a manner that allows for proper spooling of the wire rope onto the drum. When installed correctly, the direction of lift is counterclockwise as viewed from the motor end of the winch (clockwise from outboard end of winch). Refer to Dwg. MHTPA0661.
2. Mount the winch so the axis of the drum is horizontal and that the motor vent cap is not more than 15° off top vertical center. If the winch is to be mounted in an inverted position, the motor case must be rotated to position the vent cap at the top.

3. The winch mounting surface must be flat and of sufficient strength to handle the rated load plus the weight of the winch and attached equipment. An inadequate foundation may cause distortion or twisting of the winch uprights and side rails resulting in winch damage.
 - a. Make sure the mounting surface is flat to within 1/16 inch (2.0 mm). Shim if necessary.

FA MRA Series Winch Wire Rope Take Off Diagram (Overwind Operation Only)

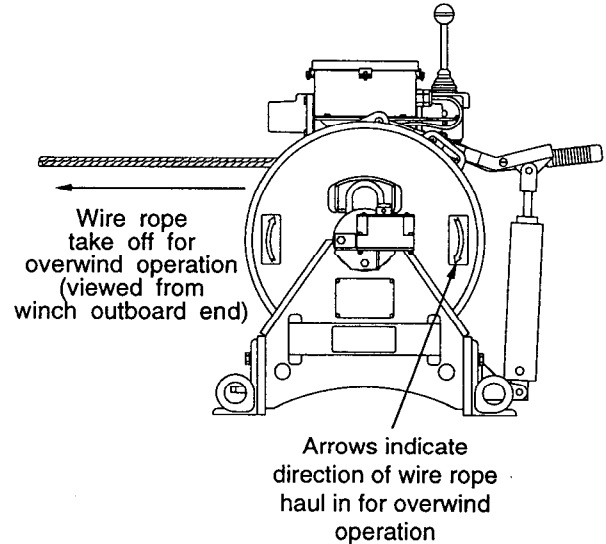

(Dwg. MHTPA0661)

4. Recommended mounting bolts: 3/4 inch (18 mm) Grade 8 or better. Use self-locking nuts or nuts with lockwashers. Refer to Dwg. MHTPA0133 and Table 1 for mounting dimension information. To determine clamping load tensile and shear strength requirements refer to Dwg. MHTPA0692 and Table 2.

Winch Bolt Hole Mounting Dimensions

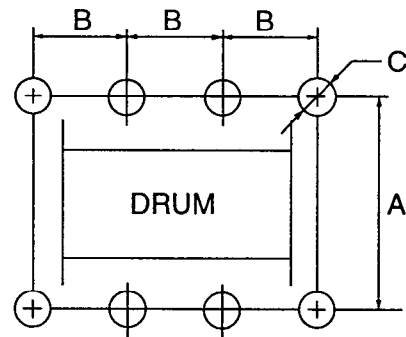

(Dwg. MHTPA0133)

Table 1: Bolt Hole Dimensions

Dimension		Drum Length (inches)					
		8	12	16	24	30*	36*
"A"	in.	31.25					
	mm	794					
"B"	in.	8	9.25	10.5	13	11.5	12.5
	mm	203	235	267	330	292	317
"C"	in.	13/16					
	mm	20					

* 5 bolts per side rail.

FA5MRA Winch Foundation Bolt Forces

Calculated for 1st Layer stall load [24,900 lbf (110,755 N)]

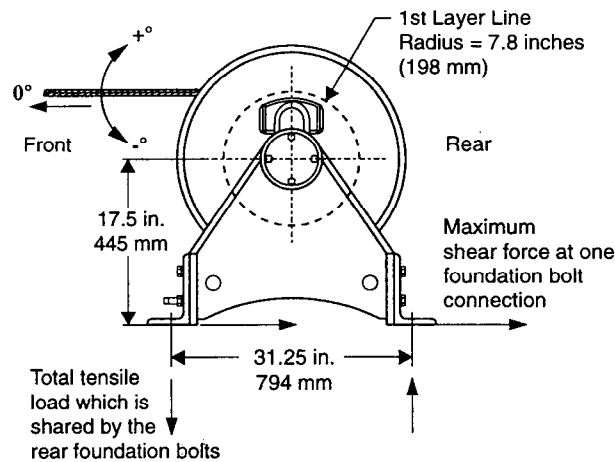

(Dwg. MHTPA0701)

Table 2: Winch Foundation Bolt Forces

Force Acting on Bolt		Drum Length (inches)					
		8	12	16	24	30	36
Maximum Shear Force at One Foundation Bolt Connection *	lbf		3,900	4,230	4,850	4,300	4,650
	N		17,347	18,815	21,573	19,126	20,683
Maximum Tensile Force Shared by Rear Foundation Bolts **	lbf	25,000					
	N	111,200					

* Maximum shear force occurs when wire rope is at a 0° angle.

** Maximum tensile force occurs when wire rope is at a 42° angle.

- Use 3/4 inch (18 mm) Grade 8 mounting bolts. Tighten evenly and torque to 380 ft. lbs. (515 Nm) for dry thread fasteners. If the fasteners are plated, lubricated or a thread locking compound is used, torque to 280 ft. lbs. (380 Nm).
- Maintain a fleet angle between the sheave and winch of no more than 1-1/2°. The lead sheave must be on a center line with the drum and for every inch of drum length, be at least 1.6 feet (0.5 metre) from the drum. Refer to Dwg. MHTPA0498.
- Do not weld to any part of the winch.

Wire Rope



- Do not use wire rope which is less than 5/8 inch (16 mm) minimum nominal diameter.
- Maintain at least 4 tight wraps of wire rope on the drum at all times. Ensure wire rope top layer is a minimum of 2 inches (51 mm) below drum flange edge. Refer to Dwg. MHTPA0498.
- To prevent wire rope "line run" ensure a weight greater than the total weight of the longest 'wire rope pay out to sheave' length is attached to the end of the wire rope. 5/8 inch IWRC wire rope average weight per foot: 0.72 lbs/foot (1.07 kg/metre).

Wire Rope and Drum Diagram

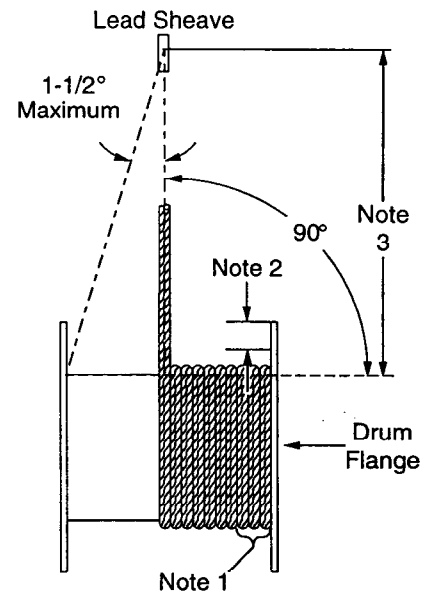

(Dwg. MHTPA0498)

Notes:

- Always maintain a minimum of 4 tight wraps of wire rope on the drum.
- The minimum allowed distance from top of wire rope layer to drum flange edge is 2 inches (51 mm).
- 1.6 feet (0.5 metre) per inch of drum length; eg., for 12 inch drum length locate lead sheave 19.2 feet (6 metres) from drum.

Wire Rope Selection

Consult a reputable wire rope manufacturer or distributor for assistance in selecting the appropriate type and size of wire rope and, where necessary, a protective coating. Use a wire rope which provides an adequate safety factor to handle the actual working load.

When considering wire rope requirements the actual working load must include not only the static or dead load but also loads resulting from acceleration, retardation and shock load. Consideration must also be given to the size of the winch wire rope drum, sheaves and method of reeving. Wire rope construction must be 6 X 19 or 6 X 37 IWRC right lay to permit correct installation of wire rope anchor. Refer to Table 3 for applicable wire rope sizes.

Table 3: Minimum and Maximum Wire Rope Size

Model	Minimum		Maximum	
	inch	mm	inch	mm
FA5 Utility	5/8	16	7/8	22
FA5 ManRider*	5/8	16	5/8	16

* 5/8 inch (16 mm) wire rope must be used on FA5MRA winches used for personnel lifting to conform to ANSI A10.22 standards.

NOTICE

• Use only 5/8 inch (16 mm) wire rope on the FA5MRA winch if used for personnel handling.

Installing Wire Rope

(Refer to Dwg. MHTPA0166)

1. Cut wire rope to length in accordance with the wire rope manufacturer's instructions.
2. Feed the end of the wire rope into the wire rope anchor hole in the drum and pull through approximately one foot (305 mm) of wire rope.

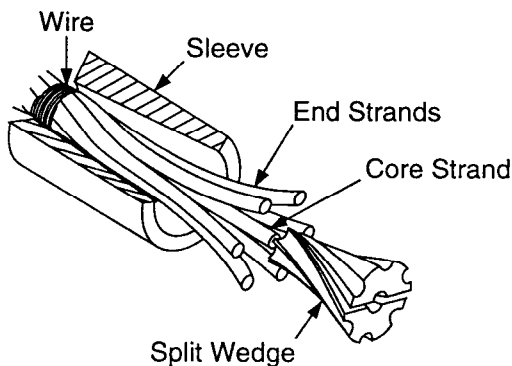

(Dwg. MHTPA0166)

3. Wrap the wire rope with wire a distance from the end equal to the wedge length plus one inch (25 mm).
4. Slide the sleeve over the end of the wire rope so the larger diameter of the taper bore is nearest the end of the wire rope.
5. Spread the end strands of the wire rope and insert the split wedge until it is below the end of the wire rope.
6. Pull the sleeve over the wire rope end until tight. Check that the wire rope strands stay in the slots located on the split wedge.
7. Pull the wire rope anchor into position in the drum anchor pocket.

CAUTION

• Make sure the first wrap of wire rope is tight and lays flush against the drum flange. Also ensure that each succeeding wrap is tight against the previous one.

Safe Wire Rope Handling Procedures

1. Always use gloves when handling wire rope.
2. Never use wire rope which is frayed or kinked.
3. Never use wire rope as a sling.
4. Always ensure wire rope is correctly spooled and the first layer is tight against the drum.

Wire Rope Spooling

To compensate for uneven spooling and the decrease in line pull capacity as the drum fills up, use as short a wire rope as practical. When rewinding apply tension to the end of the wire rope to eliminate line slack. This helps achieve level winding and tight spooling.

NOTICE

• Wire rope must be spooled at least 2 inches (51 mm) below the outer diameter of the drum flange. Refer to Dwg. MHTPA0498.

Rigging

Make sure all wire rope blocks, tackle and fasteners have a sufficient safety margin to handle the required load under all conditions. Do not allow wire rope to contact sharp edges or make sharp bends which will cause damage to wire rope, **use a sheave**. Refer to the wire rope manufacturer's handbook for proper sizing, use and care of wire rope.

Safe Installation Procedures

1. Do not use wire rope as a ground (earth) for welding.
2. Do not attach a welding electrode to winch or wire rope.
3. Never run the wire rope over a sharp edge. Use a correctly sized sheave.
4. When a lead sheave is used, it must be aligned with the center of the drum. The diameter of the lead sheave must be at least 24 times the diameter of the wire rope. Refer to Dwg. MHTPA0498.
5. Always maintain at least four full, tight wraps of wire rope on the drum.

Air Supply

The air supply must be clean and free from moisture.

Air Lines

The inside diameter of the winch air supply lines must not be less than the sizes shown in Table 4. Before making final connections, all air supply lines should be purged with clean, moisture free air or nitrogen before connecting to winch inlet. Supply lines should be as short and straight as installation conditions will permit. Long transmission lines and excessive use of fittings, elbows, tees, globe valves etc. cause a reduction in pressure due to restrictions and surface friction in the lines.

Table 4: Minimum Allowable Air Supply Line Sizes

Model	inch	mm
FA5MRA	1-1/2	38

Air Line Lubricator

(Refer to Dwg. MHTPA0191)

Always use an air line lubricator with these motors. The lubricator must have an inlet and outlet at least as large as the inlet on the motor. Install the air line lubricator as close to the air inlet on the motor as possible.

⚠ CAUTION

- Lubricator must be located no more than 10 ft. (3 m) from the motor.

The air line lubricator should be replenished daily and set to provide 6 to 9 drops per minute of SAE 10W oil. A fine mist will be exhausted from the throttle control valve when the air line lubricator is functioning properly.

Air Line Filter

(Refer to Dwg. MHTPA0191)

It is recommended that an air line strainer/filter be installed as close as practical to the motor air inlet port, but before the lubricator, to prevent dirt from entering the motor. The strainer/filter should provide 20 micron filtration and include a moisture trap. Clean the strainer/filter periodically to maintain its operating efficiency.

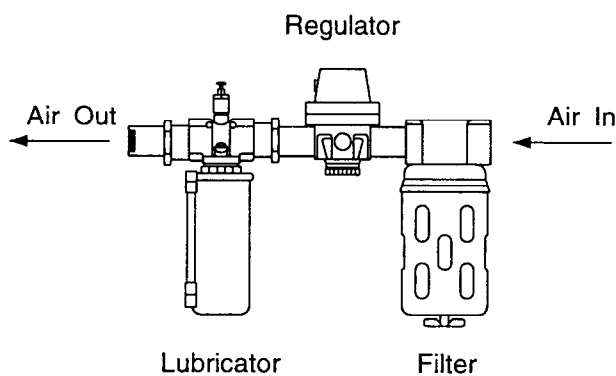

(Dwg. MHTPA0191)

Moisture in Air Lines

Moisture that reaches the air motor through air supply lines is a primary factor in determining the length of time between service overhauls. Moisture traps can help to eliminate moisture. Other methods, such as an air receiver which collects moisture before it reaches the motor, an aftercooler at the compressor that cools the air to condense and collect moisture prior to distribution through the supply lines are also helpful.

Motor

For optimum performance and maximum durability of parts, provide an air supply of 90 psig at 700 scfm (6.3 bar/630 kpa at 20 cu.m/m) for FA5MRA winches. The air motor should be installed as near as possible to the compressor or air receiver. Recommended pressures and volumes are measured at the point of entry to the air motor.

Electrical Grounding

⚠ WARNING

- The Personnel Lifting System must be properly grounded to conform to ANSI A10.22 standards. Ensure electrical grounding is conducted by licensed electricians in accordance with the latest edition of the National Electric Code (ANSI/NFPA 70) and any applicable local, state and national electric codes and ordinances.

An electrical grounding lug is attached to the winch siderail. Ensure winch is correctly grounded to the Personnel Lifting System before using winch.

Wire Rope Line Speed Monitor

Winches are equipped with a battery operated line speed monitor and overspeed indicator. Ensure the indicator sensor is adjusted as described in 'Adjustments' in the "WINCH MAINTENANCE" section.

The line speed monitor rechargeable battery will operate for twenty-five eight hour days at 33% actual on time (winch operation time). An amber light indicates the battery requires recharging. Approximately one day of operation remains when the recharge light indication comes on. Refer to 'Adjustments' in the "WINCH MAINTENANCE" section for recharging procedures.

Motor Exhaust and Muffler

(Refer to Dwg. MHTPA0646)

⚠ WARNING

- Operator exposure to noise levels shall not exceed 90 dBA over an 8 hour period (Time Weighted Average (TWA)). Ensure motor and pilot valve air is properly exhausted and muffled.

Winch noise level ratings under factory test conditions:

1. 89 dBA during operation of winch without load in the haul in direction.
2. 89 dBA during operation of winch without load in the pay out direction.

These levels were achieved when the motor and pilot valve air was exhausted through a 10 foot (3 metre) length of hose and attached to a muffler.

Initial Operating Checks

Winches are tested for proper operation prior to leaving the factory. Before the winch is placed into service the following initial operating checks should be performed.

1. When first running the motor inject some light oil into the inlet connection to provide initial lubrication.
2. When first operating the winch it is recommended that the motor be driven slowly in both directions for a few minutes.

For winches that have been in storage for a period of more than one month the following start-up procedure is required.

1. Give the winch an inspection conforming to the requirements of "Winches Not in Regular Use" in the "INSPECTION" section.

2. Pour a small amount of 10W oil in the motor inlet port.
3. Operate the motor for 10 seconds in both directions to flush out any impurities.
4. The winch is now ready for normal use.

WINCH OPERATION

The four most important aspects of winch operation are:

1. Follow all safety instructions when operating the winch.
2. Allow only people trained in safety and operation of this winch to operate this equipment.
3. Subject each winch to a regular inspection and maintenance procedure.
4. Be aware of the winch capacity and weight of load at all times.

WARNING

- Operate this winch **ONLY** if wire rope is installed to come off the drum for overwind operation. Refer to Dwg. MHTPA0564.
- Operation of this winch in a safe manner, as part of a Personnel Lifting System, requires that supervisors, operators, and personnel being transported be thoroughly instructed in the potential dangers involved and the safety procedures established to minimize the risks of accident, injury and property damage.
- Do not transport personnel and materials at the same time. Safe operation, according to established standards, require that personnel and materials are to be transported separately.
- Visual inspections of the winch and entire Personnel Lifting System must be conducted by designated personnel instructed in safety, operation and maintenance of this product before using the winch to transport personnel. Any visual indication of damage must be inspected, repaired and actions documented in accordance with component manufacturers' instructions to ensure the safety of personnel is not compromised.

Personnel Lifting System

Owners are responsible for establishing, implementing and ensuring that supervisors, operators, and personnel being transported are instructed in operation and safety procedures. Refer to 'Training' in the "WINCH OPERATION" section.

1. Supervisors, operators and personnel being lifted should check that winch, wire rope, working platform, lifelines, safety belts (harnesses), etc. are present and functional prior to authorizing personnel lifting.
2. Personnel being transported must be instructed in and adhere to the safety procedures established including, but not limited to, the following list:

- a. Emergency Escape Procedures in accordance with ANSI A10.22 Section 11.
 - b. Use of safety belts (harnesses) and rope grabs (lifelines) in accordance with ANSI A10.22 Sections 11, 12.4 and 12.5.
3. Winch operators must be instructed in and adhere to the procedures established to ensure proper and safe operation of this winch as a component in a Personnel Lifting System.
 - a. Winch operators must remain at the winch controls at all times when handling personnel and materials.
 - b. At any indication of winch, or system, damage or impending danger the winch operator must place the winch in a safe condition and notify designated personnel. Winch and system operation must be suspended until all discrepancies noted have been inspected, repaired and system tested to ensure safe operation.
 - c. Voice communication must be established and maintained between winch operator, personnel being lifted and personnel located at each landing (as applicable).
 - d. Winch operators must maintain at least 4 tight wraps of wire rope on the drum at all times.
 - e. Wire rope shall be weighted on the end to prevent line run when spooling onto the drum.

Initial Winch Operating Checks

NOTICE

- Initial operating checks specific to the entire Personnel Lifting System should be established to ensure system component compatibility.

Winches are tested for proper operation of all features prior to shipping. Before the winch is placed into service the following initial operating checks should be performed.

1. When first running the motor inject a small amount of oil into the inlet connection to provide initial and immediate lubrication.
2. When first operating the winch run the motor slowly in both directions for a few minutes.
3. Verify both drum brakes function as described in 'Winch Testing' in the "WINCH INSPECTION" section. To adjust the brakes refer to 'Winch Adjustments' in the "WINCH MAINTENANCE" section.

- Adjust and verify limit switch settings. To adjust the limit switch set points refer to 'Winch Adjustments' in the "WINCH MAINTENANCE" section.
- Verify line speed monitor and overspeed alarm operation as described in 'Winch Testing' in the "WINCH INSPECTION" section.
- Verify automatic drum brake emergency release system operation as described in 'Winch Testing' in the "WINCH INSPECTION" section.

Winch Component Operation

Pilot Air Throttle Control Lever

(Refer to Dwg. MHTPA0608)

Winch control lever directions are described as viewed when facing the winch motor and apply to overwind operation only. To ensure smooth operation of the winch sudden movements of the control valve should be avoided.

- To payout wire rope, lift up on the winch control lever and move the lever to the right.
- To haul in wire rope, lift up on the winch control lever and move the winch control lever to the left.

Pilot Air Throttle Control Operation

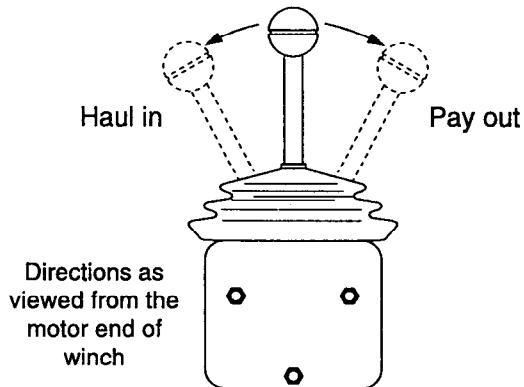

(Dwg. MHTPA0608)

Manual Drum Brake

The manual drum brake may be applied by pushing down on the brake handle and released by pulling up. If the handle is pushed down fully, it should lock in that position and prevent drum rotation, until released by the operator. The brake must be kept properly adjusted to hold the required load. To adjust the brake refer to 'Winch Adjustments' in the "WINCH MAINTENANCE" section.

Automatic Drum Brake

The automatic drum brake is a spring applied, air released brake. Using an air actuated, spring loaded cylinder the brake automatically disengages when the motor is operated. Air pressure in the cylinder overcomes spring pressure to release the brake. When the pilot air throttle control lever is placed in the neutral position, the air in the cylinder is vented and the spring automatically engages the brake to prevent drum rotation.

The cylinder clevis must be kept properly adjusted to hold the required load. To adjust the brake refer to 'Winch Adjustments' in the "WINCH MAINTENANCE" section.

Limit Switch

Pre-set limit switch settings prevent winch wire rope payout and haul in by stopping air flow to the winch motor when a set point has been reached. It is the owner's and operator's responsibility to adjust winch operating limits prior to using the winch to transport personnel. To adjust the limit switch set points refer to 'Winch Adjustments' in the "WINCH MAINTENANCE" section.

⚠ WARNING

- Ensure limit switch operates properly and that limits have been set before using winch to transport personnel.

Line Speed Monitor and Overspeed Alarm

The Line Speed Monitor is a battery powered wire rope line speed indicator system which determines line speed by sensing drum rotation.

The Line Speed Monitor provides a visual alarm (flashing red light) and digital readout (in feet) to allow the operator to adjust throttle control to maintain wire rope line speed at 100 feet per minute (30.5 metres per minute) or less. Line Speed Monitors are factory pre-set to match the winch installed on and cannot be adjusted. The overspeed indicator light flashes when drum speed exceeds wire rope line speeds of 100 feet per minute (+/- 10 feet) (30.5 metres per minute; +/- 3 metres) in either direction of drum rotation.

The Line Speed Monitor battery should be recharged as described in 'Adjustments' in the "WINCH MAINTENANCE" section.

Winch Emergency Descent Procedure

⚠ CAUTION

- ANSI A10.22-1990 Section 11 defines the Personnel Lifting System requirements for establishing emergency escape methods and procedures. The following procedure describing the use of the winch to lower personnel or loads when the supply air to the winch has been interrupted should only be used after all other established methods have been exhausted.

The lowering speed of the load using the winch descent procedure is dependent upon the weight of the load, amount of cable on the drum, and position of the load in the lifting system.

To use the winch to lower the load when the air supply has been interrupted conduct the following:

- Engage the manual band brake.
- Depress the automatic band brake clevis and remove cotter pin and pin to disconnect cylinder (110) from brake lever.
- Slowly disengage manual band brake using the brake lever. Regulate speed of load using manual band brake. If load does not lower engage band brake and then conduct the following step.
- Remove capscrews from motor adapter valve and remove pilot valve/adaptor assembly from winch motor.

- Use the manual band brake to throttle lowering speed (if required) when lowering the load.

Training

Prior to using the Personnel Lifting System supervisors, operators, service personnel, and personnel being transported must be thoroughly instructed in the potential dangers involved and the safety procedures established to minimize the risks of accident, injury and property damage.

Establishment of safe operating procedures for the Personnel Lifting System should be based on ANSI A10.22 specifications, OSHA regulations, all applicable local, state and national standards, system component manufacturers's recommendations, and system designer recommendations.

Records of training should be maintained and made available to designated personnel for review.

WINCH LUBRICATION

To ensure continued satisfactory operation of the winch, all points requiring lubrication must be serviced with the correct lubricant at the proper time interval as indicated for each assembly.

The lubrication intervals recommended in this manual are based on intermittent operation of the winch eight hours each day, five days per week. If the winch is operated almost continuously or more than the eight hours each day, more frequent lubrication will be required. Also, the lubricant types and change intervals are based on operation in an environment relatively free of dust, moisture, and corrosive fumes. Use only those lubricants recommended. Other lubricants may affect the performance of the winch. Approval for the use of other lubricants must be obtained from your **Ingersoll-Rand** distributor. Failure to observe this precaution may result in damage to the winch and/or its associated components.

INTERVAL	LUBRICATION CHECKS
Start of each shift	Check flow and level of air line lubricator (approximately 6 to 9 drops per minute required at maximum motor speed).
	Check winch motor oil level.
Monthly	Lubricate components supplied by grease fittings.
	Inspect and clean or replace air line filter.
	Check reduction gear oil level.
Yearly	Drain and refill winch reduction gear oil.
	Drain and refill winch motor oil.

Note: Intervals are based on winch operation in a normal environment as described in the "INSPECTION" section. In 'Heavy' or 'Severe' operating conditions adjust lubrication intervals accordingly.

Recommended Lubricants

Oil

Temperature	Type Oil
1. Below 32° F (0° C)	SAE 10W
2. 32° to 80° F (0° to 27° C)	SAE 20W
3. Above 80° F (27° C)	SAE 30W

Grease

Temperature	Type Grease
1. -20° to 50° F (-30° to 10° C)	EP 1 multipurpose lithium-based grease
2. 30° to 120° F (-1° to 49° C)	EP 2 multipurpose lithium-based grease

Motor

(Refer to Dwg. MHTPA0565)

Correct lubrication is one of the most important factors in maintaining efficient winch operation. The motor is splash lubricated by the oil in the motor housing and has no other means of lubrication. It is therefore important to use only quality, non-detergent motor oil to ensure maximum performance and minimum downtime for repairs. Refer to the 'Recommended Lubricants' section. Allow oil to settle before topping off.

Oil capacity for the **FA5MRA** winch motor is 3 quarts (2.8 litres). Add oil through the fill plug opening until oil flows from the level plug hole. Add oil slowly to prevent spilling.

The motor should be level-checked daily or at the start of each shift after accumulated water has been drained off. When motors are operated in temperatures below freezing, wait long enough at end of shift for water to separate from oil but not long enough for it to freeze. Drain the water then refill to the level plug. If desired, all the oil may be drained at the end of the shift and the motor refilled with new oil.

Motor Lubrication Locations

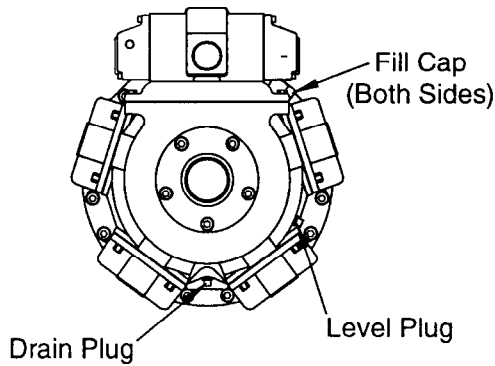

(Dwg. MHTPA0565)

Wire Rope

Follow the wire rope manufacturer's instructions. At a minimum, observe the following guidelines.

1. Clean with a brush or steam to remove dirt, rock dust or other foreign material on the surface of the wire rope.



• Do not use an acid-based solvent. Only use cleaning fluids and lubricants specified by the wire rope manufacturer.

2. Apply a wire rope lubricant, **Ingersoll-Rand LUBRI-LINK GREEN** or SAE 30W oil.
3. Brush, drip or spray lubricant weekly, or more frequently, depending on severity of service.

Reduction Gear Assembly

(Refer to Dwg. MHTPA0140)

The reduction gear assembly is filled and shipped with oil from the factory. Check oil level before initial winch operation. If the winch is used at a normal frequency replace the oil in the reduction housing once every year. To ensure correct performance, highest efficiency and long life, it is essential that the lubricating oil be maintained at the correct level. Rotate the drum until the fill plug is located at top dead center then add oil up to the level plug hole. Oil capacity for the reduction gear assembly is 4 quarts (3.8 litres).



• Do not over fill. Excess oil will reduce operating efficiency and increase oil temperature.

The recommended grade of oil must be used at all times since the use of unsuitable oil may result in excessive temperature rise, loss of efficiency and possible damage to the gears. Refer to the 'Recommended Lubricants' section. Use only high quality lubricants in the reduction gear assembly such as motor oil, high grade EP type hydraulic oil or their equivalents.

Reduction Gear Lubrication Plug Locations

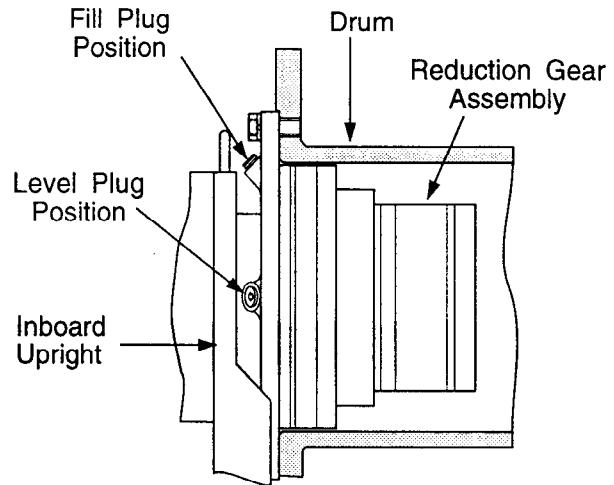

(Dwg. MHTPA0140)

Drum Brakes

Lubricate pivot points, pins and shafts with recommended grease to prevent corrosion of parts.



• Do not allow grease or oil to come into contact with drum band brake linings.

Disc Brake (optional feature)

Oil from the reduction gear assembly also provides lubrication for the disc brake. After an oil change or winch overhaul remove the breather plug and pour 6 to 8 ounces (0.2 litres) through the breather hole in the brake housing to initially lubricate the brake discs. Refer to the 'Recommended Lubricants' section. Reinstall the breather plug before operation of winch or brakes.

Seals and Bearings

If winch is disassembled, clean all parts thoroughly and coat bearings and seals with clean grease. Refer to the 'Recommended Lubricants' section. Use sufficient grease to provide a good protective coat. Lubricate grease fittings monthly with 2 or 3 pumps of a grease gun.

Air Line Lubricator

Replenish lubricator **daily** and set to provide 6 to 9 drops of oil per minute. Refer to the 'Recommended Lubricants' section for recommended oil.

Wire Rope Line Speed Monitor

Does not require lubrication.

Limit Switch

Does not require lubrication.

Inspection information is based in part on American National Standards Institute Safety Codes (A10.22 and B30.7).

Records and Reports

Personnel Lifting System

Owners are responsible for establishing and implementing operation and safety procedure training for all personnel involved in the use and operation of a Personnel Lifting System.

1. **PERSONNEL TRAINING.** Records of training provided to supervisors, operators, service personnel and personnel being transported should be maintained and made available to designated personnel for review.
2. **SYSTEM MAINTENANCE.** Records of all service, maintenance and testing performed on the Personnel Lifting System should be maintained and made available to designated personnel for review.

Winch Records and Reports

Inspection records, listing all points requiring inspection, should be maintained for all load bearing equipment. Written reports, based on **Initial, Weekly and Quarterly** inspections, should be made on the condition of critical parts as a method of documenting inspections. These reports should be dated, signed by the person who supervised the performance of the inspection, and kept on file where they are readily available for review. A sample winch 'Inspection and Maintenance Report' has been provided at the end of this section.

Wire Rope Reports

Records should be maintained as part of a long-range wire rope inspection program. Records should include the condition of wire rope removed from service. Accurate records will establish a relationship between visual observations noted during frequent inspections and the actual condition of wire rope as determined by periodic inspections.

Personnel Lifting System wire rope records should be maintained and made available to designated personnel for review.

System Inspections and Tests



• **Information provided by Ingersoll-Rand is applicable only to the winch to assist in determining the condition of the winch components described. References to other Personnel Lifting System components are made with respect to their relationship to the winch. For specific information on system components other than the winch, reference the manufacturers' literature and ANSI A10.22.**

Personnel Lifting System inspections and tests of installed components, functions and safety devices should be established based on procedures derived from ANSI A10.22 specifications, OSHA regulations, manufacturers' literature and recommendations, system designer recommendations and all applicable local, state and national standards.

1. **SYSTEM.** Frequency of inspections:
 - a. Initial system inspection.
 - b. Daily checks and Weekly inspections.
 - c. Quarterly inspections.

System Initial and Quarterly Inspections

In addition to established Daily and Weekly inspections conduct the following:

NOTICE

• **The static drop test is only required for guided cage systems.**

1. **INITIAL INSPECTION.** With the cage **at rated load, on a guided cage system**, using dead weights, conduct a static drop test. This test is designed to ensure the cage safety clamps engage and stop the cage from falling. Perform requirements of the weekly inspection.
2. **QUARTERLY INSPECTION.** With the cage **empty, on a guided cage system**, conduct a static drop test. This test is designed to ensure the cage safety clamps engage and stop the cage from falling. Perform requirements of the weekly inspection.

System Testing

Personnel Lifting System testing should be conducted in accordance with the system specific instructional manual and component manufacturers' recommendations. A system specific instruction manual must be compiled to conform to the requirements of ANSI A10.22, and detail the operation, maintenance and safety requirements of the various components comprising the personnel lifting system.

Winch Inspections

The following listed inspections apply only to the winch. These inspections should be conducted when scheduled, when indicated by winch performance and when the winch is disassembled for repair.

Careful inspection on a regular basis will reveal potentially dangerous conditions while still in the early stages, allowing corrective action to be taken before the condition becomes dangerous.

Damage revealed through inspection, or noted during operation, must be reported to designated personnel instructed in safety, operation and maintenance of this equipment. A determination as to whether a condition constitutes a safety hazard must be made, and the correction of noted safety hazards accomplished and documented by written report before placing the equipment in service.

⚠ WARNING

• **All new, altered or modified equipment should be inspected and tested by personnel instructed in safety, operation and maintenance of this equipment to ensure safe operation at rated specifications before placing equipment in service.**

• **Never use a winch that inspection indicates is damaged.**

• **Prior to using the winch to lift personnel, an initial inspection should be conducted after assembly, major repairs or alteration, and when the system has been idle for periods of longer than one month.**

Daily checks, weekly and quarterly inspections should be performed on equipment in regular use.

1. **Daily checks** are visual examinations performed by operators or personnel instructed in safety and operation of this equipment and include observations made during routine equipment operation.
2. **Weekly inspections** are thorough inspections conducted by personnel instructed in safety, operation and maintenance of this equipment. Weekly inspections are also required prior to personnel lifting if the system has been idle for periods in excess of one week, but less than one month.
3. **Quarterly inspections** are a combination of weekly inspection requirements and the performance of a static drop test **on guided cage systems only** to verify operation of the cage's safety clamp.

Winch Daily Checks and Weekly Inspections

On equipment in continuous service, weekly inspections are required. Maintain written records of weekly inspections to provide an accumulative basis for continuing evaluation. Disassembly may be required as a result of inspection findings.

In addition, daily checks, or visual inspections should be conducted by operators during regular operation for damage or evidence of malfunction.

1. **WINCH (DAILY).** At the beginning of the shift, prior to operation, visually inspect winch housings, controls, brakes, siderails and drum for indications of damage. Do not operate the winch until all discrepancies noted have been reviewed, inspected further and corrected by personnel instructed in the operation, safety and maintenance of this winch.

WINCH (WEEKLY). Inspect the following:

- a. **SIDE RAILS AND END UPRIGHTS.** Check for deformed, cracked or corroded main components. Replace damaged parts.

- b. **FASTENERS.** Check retainer rings, split pins, capscrews, nuts, and other fasteners on winch, including mounting bolts. Replace if missing or damaged and tighten if loose.
 - c. **DRUM AND SHEAVES.** Check for cracks, wear or damage. Replace damaged parts.
2. **WIRE ROPE.** Visually inspect all wire rope which can be expected to be in use during the day's operations. Inspect for wear and damage indicated by distortion of wire rope such as kinking, "birdcaging," core protrusion, main strand displacement, corrosion, broken or cut strands. If damage is evident, do not operate winch until the discrepancies have been reviewed and inspected further by an experienced wire rope inspector.

NOTICE

• **The full extent of wire rope wear cannot be determined by visual inspection. At any indication of wear inspect the wire rope in accordance with the following instructions.**

In addition to daily check requirements, also inspect for the following weekly:

- a. Ensure wire rope is spooled onto the drum for overwind operation only and that a minimum of 2 inches (50 mm) clearance is maintained between the outside edge of the drum flange and the outermost layer of wire rope.
- b. Buildup of dirt and corrosion. Clean with steam or a stiff wire brush to remove dirt and corrosion if necessary.
- c. Loose, frayed or damaged end connection. Replace if loose, frayed or damaged. Ensure ends will not catch on personnel.
- d. Ensure the wire rope is securely anchored in the winch drum.
- e. Verify wire rope diameter. Measure the diameter of the wire rope from crown-to-crown throughout the life of the wire rope. Recording of the actual diameter should only be done with the wire rope under equivalent loading and in the same operating section as accomplished during previous inspections. If the actual diameter of the wire rope has decreased more than 1/64 inch (0.4 mm) a thorough examination of the wire rope should be conducted by an experienced inspector to determine the suitability of the wire rope to remain in service. (Refer to Dwg. MHTPA0056).

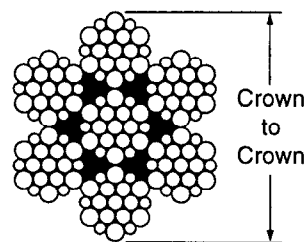

(Dwg. MHTPA0056)

3. **AIR SYSTEM (WEEKLY).** Visually inspect all connections, fittings, hoses and components for indication of air leaks. Repair any leaks and replace damaged components.
4. **CONTROLS (DAILY AND WEEKLY).** During operation of winch, verify response to control is quick and smooth. If winch responds slowly or movement is unsatisfactory, do not operate winch until all problems have been corrected.
5. **BRAKES (WEEKLY).** Ensure proper operation. Verify each brake system will hold a 150% rated load with full drum (as applicable to normal use) without slipping. If indicated by poor operation or visual damage, disassemble and repair brake(s). Check all brake surfaces for wear, deformation or foreign deposits. If drum brake lining thickness is 0.062 inch (2 mm) or less anywhere along its edge replace brake bands or linings. Clean and replace components as necessary. Test each brake system independently.
6. **LIMIT SWITCHES (WEEKLY).** Verify winch limit switches operate at the set limits. When actuated, limit switches interrupt air flow to the motor in the direction of winch operation only. Adjust limit settings or repair to correct all noted discrepancies.
7. **ALL COMPONENTS (WEEKLY).** Inspect for wear, damage, distortion, deformation and cleanliness. If external evidence indicates damage, disassemble as required to conduct a detailed inspection. Inspect gears, shafts, bearings, springs and covers. Replace worn or damaged parts. Clean, lubricate and reassemble.
8. **SUPPORTING STRUCTURE (WEEKLY).** Check for distortion, wear and continued ability to support winch. Ensure winch is firmly mounted and that fasteners are in good condition and tight.
9. **LABELS AND TAGS (WEEKLY).** Check for presence and legibility of labels. Replace if damaged or missing.
10. **WIRE ROPE LINE SPEED MONITOR.** Verify Line Speed Monitor displays line speed and overspeed alarm lights at 100 feet per minute (+/- 10 feet) (30.5 metres per minute; +/- 3 metres). If battery charge light is on, charge battery.
11. **WINCH EXHAUST AND MUFFLER.** Visually inspect exhaust hoses, connections and muffler for damage. Ensure piping and muffler are correctly installed and direct exhaust away from winch operator. Operator noise levels must not exceed 90 dBA over an 8 hour period (Time Weighted Average (TWA)).
12. Ensure electrical ground (earth) is firmly connected and that wire is in good condition. Replace wire if corroded or damaged.

Winch Initial and Quarterly Inspections

Disassembly may be required as a result of inspection findings or in order to properly inspect the individual components. Maintain written records of initial and quarterly inspections to provide an accumulative basis for continuing evaluation. Inspect all items listed in "Weekly Inspection." Also conduct the following:

1. **INITIAL INSPECTION.** Conduct all requirements of 'Winch Daily and Weekly Inspection' and 'Winch Testing'.
2. **QUARTERLY INSPECTION.** Conduct all requirements of 'Winch Daily and Weekly Inspection' and 'Winch Testing'.

Winches Not in Regular Service

1. Equipment which has been idle for a period of one week or more, but less than one month, shall be given an inspection conforming to the requirements of "Daily and Weekly Inspections" before being placed in service.
2. Equipment which has been idle for a period of over one month shall be given a complete inspection conforming with the requirements of "Initial and Quarterly Inspections" before being placed in service.

INSPECTION AND MAINTENANCE REPORT

Ingersoll-Rand Force 5 Series Ansi Manrider® Air Winch

Model Number:		Date:
Serial Number:		Inspected by:
Reason for Inspection: (Check Applicable Box)		
<input type="checkbox"/>	1. Scheduled Inspection (<input type="checkbox"/> Weekly <input type="checkbox"/> Quarterly <input type="checkbox"/> Initial)	Operating Environment: Normal <input type="checkbox"/> Heavy <input type="checkbox"/> Severe <input type="checkbox"/>
<input type="checkbox"/>	2. Discrepancy(s) noted during Daily Inspection	
<input type="checkbox"/>	3. Discrepancy(s) noted during maintenance	
<input type="checkbox"/>	4. Other: _____	

Refer to the Parts, Operation and Maintenance Manual "INSPECTION" section for general inspection criteria. Also, refer to appropriate National Standards and codes of practice. If in doubt about an existing condition contact the nearest Ingersoll-Rand Distributor or the factory for technical assistance.

COMPONENT	CONDITION		CORRECTIVE ACTION		NOTES
	Pass	Fail	Repair	Replace	
Side Rails and End Uprights					
Manual Drum Band Brake (150% Load Test)					
Automatic Drum Band Brake (150% Load Test)					
Drum Band Brakes (Visual Inspection)					
Motor					
Limit Switches					
Controls					
Air System					
Fasteners					
Reduction Gears					
Labels and Tags			---		
Shafts					
Wire Rope Anchor Wedge			---		
Line Speed Monitor and Overspeed Alarm			---		
Other Components (list in NOTES section)					

TESTING	Pass	Fail	NOTES
Operational (No Load)			
Operational (10% Load)			
Operational (Maximum Test Load *)			

* Maximum winch operational test load is 125% of rated line pull.
Maximum brake test load is 150% of rated line pull; perform by raising the test load approximately 4 to 6 inches (100 to 150 mm).

WINCH TROUBLESHOOTING

This section provides basic troubleshooting information. Determination of specific causes to problems are best identified by thorough inspections performed by personnel instructed in safety, operation and maintenance of this equipment. The chart below provides a brief guide to common winch problems, probable causes and solutions.

PROBLEM	CAUSE	SOLUTION
Winch will not operate.	No air supply to winch.	Check air supply line connections and hoses.
	Winch is overloaded.	Reduce load to within rated capacity.
	Automatic drum band brake does not release.	Pressurize brake release port and check for leakage. Replace brake piston seals if leakage is found.
	Limit switch engaged.	Shift pilot valve throttle lever in opposite direction. If winch operates, adjust limit switch settings.
	Shipping plugs may still be in place.	Remove shipping plugs in valve and motor exhaust ports.
Load continues to move when winch is stopped.	Automatic drum band brake is slipping.	Check brake band adjustment and brake band lining wear.
	Winch is overloaded.	Reduce load to within rated capacity.
	Pilot air throttle control valve sticking.	Disassemble, inspect and repair the pilot air control throttle valve.
Winch does not lift load.	Motor may be damaged.	Remove and disassemble motor. Examine all parts and replace any that are worn or damaged.
	Insufficient air supply.	Verify air supply pressure and volume at winch inlet meets the requirements listed in the "SPECIFICATIONS" section. Clean air line filter.
	Automatic drum band brake does not release.	Disassemble, inspect and repair the automatic drum band.
Throttle lever moves but winch does not operate.	Motor may be damaged.	Disassemble and clean the motor and replace any broken or damaged parts.
	Insufficient air supply.	Ensure the air pressure at the winch inlet is at least 90 psig (6.3 bar) at rated volume. Clean air line filter.
	Limit switch engaged.	Shift pilot valve throttle lever in opposite direction. If winch operates, adjust limit switch settings.
Motor runs hot or makes excessive noise during operation.	Low oil level.	Check oil level in the motor. Add oil as required to obtain the proper level.
	Improper lubrication.	Replace oil with type recommended in the "LUBRICATION" section.
	Water in oil.	Drain and refill with recommended oil. Operate winch with no load slowly, in both directions. If noise still exists or motor overheats disassemble and repair motor.
	Damaged or broken piston or connecting rod.	Disassemble and repair motor.
Winch runs slow.	Improper hose or fitting sizes.	Check fittings, connections and hoses for correct size and length. Replace parts that may cause restricted air flow. Inspect air line filter.
	Motor may be damaged.	Remove and disassemble motor as described in the "MAINTENANCE" section. Inspect all parts and replace all worn or damaged parts.

PROBLEM	CAUSE	SOLUTION
Air lines freeze.	Water in air supply.	Install or drain air system moisture traps, moisture collecting air receivers and compressor aftercoolers. After corrective action has been taken, disconnect lines at winch inlet and purge with clean, dry air or nitrogen.

Automatic Drum Brake:

Brake cylinder will not release.	Drum brake out of adjustment.	Adjust drum brake to maintain correct cylinder stroke.
	Damaged or leaking cylinder seals.	If air is noticed escaping from the cylinder breather when attempting to release the brake replace or repair cylinder.
	Dirty filter in air supply.	Clean or replace filter.
	Faulty dump valve.	Check dump valve exhaust port. Air should exhaust when control valve handle is in neutral. If no air escapes, replace dump valve.
	Low air supply pressure.	Ensure supply air pressure at the brake inlet is at least 50 psig (3.4 bar).
	Leaking diaphragm.	Disassemble brake and replace diaphragm.
	No release pressure at the brake port.	Verify proper operation of winch controls.

WINCH MAINTENANCE

⚠ WARNING

- Never perform maintenance on the winch while it is supporting a load.
- Before performing maintenance, tag controls:
DANGER - DO NOT OPERATE - EQUIPMENT BEING REPAIRED.
- Only allow service personnel trained in safety and maintenance on this winch to perform maintenance.

NOTICE

- Contact your nearest distributor or the factory for winch disassembly and/or assembly instructions.

Reduction Gear Assembly

It is recommended that the first oil change be done after approximately 50 hours initial operation. Always inspect removed oil for evidence of internal damage (metal shavings, dirt, water, etc.).

Check the oil in the reduction housing as recommended in the "LUBRICATION" section. If low, replenish. The oil should be changed at least once every year.

Refer to the "LUBRICATION" section for recommended oil.

INTERVAL	MAINTENANCE CHECK
Start of each shift (Operator or Maintenance Personnel)	<p>Make a thorough visual inspection of the winch for damage. Do not operate the winch if damaged.</p> <p>Operate the winch at low RPM in both directions. Winch must operate smoothly without sticking, binding or abnormal noises. Check the operation of the brake(s).</p>
3 Months (Maintenance Personnel)	Inspect the drum brake friction linings. Clean or replace parts as required. Adjust drum brake as necessary.
Yearly (Maintenance Personnel)	<p>Inspect the winch gearing, shafts and bearings for wear and damage. Repair or replace as necessary.</p> <p>Check all the supporting members, including the foundation, fasteners, nuts, sheaves and rigging, etc. for indications of damage or wear. Repair or replace as required.</p>

Winch Adjustments

Disc Brake (optional feature) Adjustment

Brake adjustment is **not** required. If the disc brake does not hold the rated load disassemble and repair.

If the brake assembly is removed or repaired ensure the breather is installed and located at the top of the brake housing during reassembly.

Manual Drum Brake Adjustment

1. Release wire rope tension on the drum.
2. Raise handle to free brake bands.
3. Remove cotter pin and pin.
4. Rotate link stud clockwise to increase brake torque.
5. Install pin and check adjustment.
6. Brake should be adjusted until brake lever over center position can be attained with 50 to 100 lb. (23 to 45 kg) force on the handle.
7. Install cotter pin when adjustment is completed.

⚠ CAUTION

- When any part of the brake lining measures 0.062 inch (2 mm) or less, brake bands (128) or linings must be replaced.

Automatic Drum Brake Adjustment

1. Remove cotter pin and washer at adjustment clevis.
2. Apply air to the brake cylinder and remove pin and second washer to disconnect clevis from brake lever.
3. Clevis adjustments:
 - a. To decrease brake torque, turn adjustment clevis clockwise to increase cylinder rod extension.
 - b. To increase brake torque, turn clevis counterclockwise to decrease cylinder rod extension.
4. Assemble clevis to brake lever with washer and pin. Release air to brake cylinder.
5. Test brake as described in 'Winch Testing' in the "WINCH MAINTENANCE" section. Readjust if necessary.
6. Install cotter pin and second washer to secure clevis to brake lever when adjustments are complete.

Pilot Air Control Valve Adjustment

If winch operating speeds differ from performance specifications the pilot air control valve may require adjustment. Loosen nut and adjust adjusting screw, located in the valve end cap, until drum speed for no-load haul in equals the drum speed for full load pay out.

Limit Switch Adjustment

(Refer to Dwg. MHTPA0607)

⚠ CAUTION

- Maintain at least 4 tight wraps of wire rope on the drum at all times. Ensure wire rope top layer is a minimum of 2 inches (50 mm) below drum flange edge. Refer to Dwg. MHTPA0498.

The FA5MRA air lines and connections are color coded to assist in assembly. Refer to the following table in determining air connections by color coding.

Adjustments described as viewed when facing the limit switch assembly from the automatic brake cylinder side of the winch.

Limit Switch Adjustment

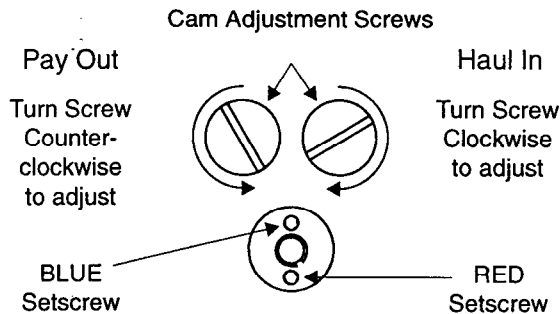

(Dwg. MHTPA0607)

Winch Air System Color Code

Winch Direction	Limit Switch Connections	Pilot Air Valve Manifold to Throttle
Haul In	Yellow	Brown
Pay Out	Green	Blue

Winch Direction	Supply Air	Limit Switch Setscrews
Haul In	Red	Red
Pay Out		Blue

To set winch maximum wire rope pay out limit switch:

1. Remove access plate from top of limit switch.
2. Loosen the blue setscrew in the center of the limit switch, below the access cover.
3. Position winch wire rope at desired pay out position.
4. Rotate the left cam adjustment screw counterclockwise until it fully activates the cutoff valve, causing system air to vent. 2-3/4 turns of the cam adjustment screw are required for each full cam revolution.
5. Hold the cam adjustment screw in position (venting air) and tighten the blue setscrew.
6. Adjust haul in limit switch. Test winch setpoints by operating the winch through three complete cycles to ensure constant limit switch operation within +/- 2 feet (2/3 m) of setpoints.
7. Install access cover when final adjustments are complete.

To set winch maximum wire rope haul in limit switch:

1. Remove access plate from top of limit switch.
2. Loosen the red setscrew in the center of the limit switch, below the access cover.
3. Position winch wire rope at desired pay out position.
4. Rotate the right cam adjustment screw clockwise until it fully activates the cutoff valve, causing system air to vent. 2-3/4 turns of the cam adjustment screw are required for each full cam revolution.
5. Hold the cam adjustment screw in position (venting air) and tighten the blue setscrew.
6. Adjust haul in limit switch. Test winch setpoints by operating the winch through three complete cycles to ensure constant limit switch operation within +/- 2 feet (2/3 m) feet of setpoints.

7. Install access cover when final adjustments are complete.

Wire Rope Line Speed Monitor and Overspeed Alarm Adjustment

Line speed monitor adjustments are limited to the placement of the sensor. Adjustments to the indicator set points established at the factory should not be attempted. To change line speed monitor set points contact your nearest **Ingersoll-Rand** distributor or the factory.

1. The sensor attaches to the assembly bracket and faces the drum reduction gear mounting capscrews.
2. Install the sensor and adjust to ensure a clearance of 0.2 inch (+/- 0.1 inch) [5 mm (+/- 2.5 mm)] between the sensor and the drum reduction gear mounting capscrew heads. Refer to Dwg. MHTPA0602.

Overspeed Indicator Sensor Clearance

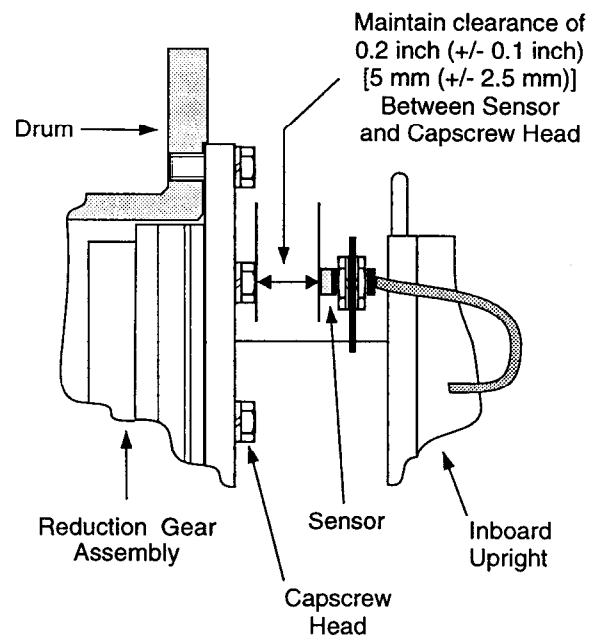

(Dwg. MHTPA0602)

Wire Rope Line Speed Monitor and Overspeed Alarm Battery Charging

It is recommended the battery be charged for 24 hours every two weeks or as indicated by illumination of the battery charge light.

To charge the battery connect the battery charger unit to the monitor and an 110 volt (ac) electrical source. Allow the battery to charge for 24 hours.

Winch Testing

Prior to initial use, all new, altered or repaired winches shall be tested to ensure proper operation at rated capacity. Testing loads should be based on the utility rating of the winch. The **FA5-MRA** with 5/8 inch (16 mm) wire rope is rated for a maximum 7,040 lbs. (3,200 kg) rated line pull.

1. **OPERATIONAL TEST.** Prior to initial use, all new, altered or repaired winches shall be tested to ensure proper operation.

- a. Check oil level in motor, reduction gear assembly and disc brake are correct.
 - b. To initially 'break in' new or overhauled motors operate without load, in both directions, for 2 hours at 100 - 200 RPM.
 - c. New Drum Brake Band Lining Run-in Procedure: All new drum brake band linings require a 'run-in' period. Operate the winch without load in the payout direction while gradually applying the brake. Allow the brake to slip for approximately one minute. Winch motor may stall as drum brake band lining fully engages. Do not allow brake to overheat.
 - d. Check operation of brakes. Adjust if necessary as described in the "WINCH MAINTENANCE" section.
 - e. Check operation of limit switches, locking devices and all safety devices when equipped.
 - f. Check foundation mounting fasteners are secure.
 - g. Install drum guard when provided.
2. **LOAD TEST.** Prior to initial use, all new, extensively repaired, or altered winches shall be load tested by or under the direction of a person trained in the operation and safety of this winch and a written report furnished confirming the rating of the winch. Load winch to **at least 100%, but not more than 125%** of the rated utility line pull and operationally test winch. Operate winch in both directions. Winch must operate smoothly, without indication of binding or

malfunction.

- a. To test the winch at **125%** of the rated utility load of 7,040 lbs. (3,200 kg) apply the following load with the wire rope on the first layer of the drum:

FA5MRA Winch

8,800 lb. (3,992 kg)

3. **LINESPEED INDICATOR AND OVERSPEED ALARM.** During operational and load tests, observe winch line speed. Maximum allowed line speed, when used as a **ManRider®**, should not exceed 100 ft./min (30.5 m/min). The visual overspeed alarm must activate when line speed reaches 100 ft./min (+/- 10 ft) (30.5 m/min (+/- 3 m)).
4. **BRAKES.** Test the drum automatic and manual band brakes independently. Each brake shall hold **150%** of rated load without slipping. Automatic drum band brake must stop and hold test load when the winch throttle lever is placed in the neutral position. Manual drum band brake must be able to stop and hold test load when the winch throttle lever is placed in the neutral position and brake is applied.
5. **LIMIT SWITCHES.** Operate winch in both directions to activate limit switches. Limit switches should engage at established settings (+/- 2 feet (2/3 m)), and prevent winch operation must reset after reversing winch operating direction and allowing drum to turn approximately three full revolutions.

SERVICE NOTES

SERVICE NOTES

PARTS ORDERING INFORMATION

The use of other than **Ingersoll-Rand** Material Handling replacement parts may invalidate the Company's warranty.

For your convenience and future reference it is recommended that the following information be recorded.

Model Number _____

Serial Number _____

Date Purchased _____

When ordering replacement parts, please specify the following:

1. Complete model number and serial number as it appears on the nameplate.
2. Part number(s) and part description as shown in this manual.
3. Quantity required.

The nameplate is located on the winch outboard upright.

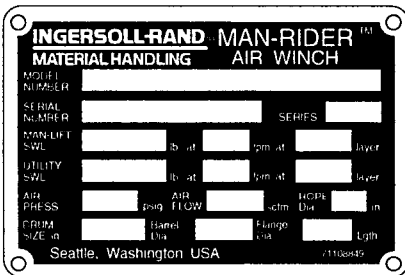

NOTICE

- Continuing improvement and advancement of design may cause changes to this equipment which are not included in this manual. Manuals are periodically revised to incorporate changes. Always check the manual edition number on the front cover for the latest issue.
- Sections of this manual may not apply to your winch.
- Using other than genuine Ingersoll-Rand Material Handling parts may adversely affect the safe operation of this product.

Return Goods Policy

Ingersoll-Rand will not accept any returned goods for warranty or service work unless prior arrangements have been made and written authorization has been provided from the location where the goods were purchased. Winches which have been modified without **Ingersoll-Rand** approval, mishandled or overloaded will not be repaired or replaced under warranty. A printed copy of the warranty which applies to this winch is provided inside the back cover of this manual.

Disposal

When the life of the unit has expired, it is recommended that it be disassembled, degreased and parts separated as to materials so that they may be recycled.

For additional information contact:

Ingersoll-Rand Material Handling
P.O. Box 24046
2724 Sixth Avenue South
Seattle, WA 98124-0046 USA
Phone: (206) 624-0466
Fax: (206) 624-6265

or

Ingersoll-Rand Material Handling
Douai Operations
111, avenue Roger Salengro
59450 Sin Le Noble, France
Phone: (33) 27-93-08-08
Fax: (33) 27-93-08-00

HOIST AND WINCH LIMITED WARRANTY

Ingersoll-Rand Company (I-R) warrants to the original user its Hoists and Winches (Products) to be free of defects in material and workmanship for a period of one year from the date of purchase. I-R will repair, without cost, any Product found to be defective, including parts and labor charges, or at its option, will replace such Products or refund the purchase price less a reasonable allowance for depreciation, in exchange for the Product. Repairs or replacements are warranted for the remainder of the original warranty period.

If any Product proves defective within its original one year warranty period, it should be returned to any Authorized Hoist and Winch Service Distributor, transportation prepaid with proof of purchase or warranty card.

This warranty does not apply to Products which I-R has determined to have been misused or abused, improperly maintained by the user, or where the malfunction or defect can be attributed to the use of non-genuine I-R parts.

I-R makes no other warranty, and all implied warranties including any warranty of merchantability or fitness for a particular purpose are limited to the duration of the expressed warranty period as set forth above. I-R's maximum liability is limited to the purchase price of the Product and in no event shall I-R be liable for any consequential, indirect, incidental, or special damages of any nature rising from the sale or use of the Product, whether based on contract, tort, or otherwise.

Note: Some states do not allow limitations on incidental or consequential damages or how long an implied warranty lasts so that the above limitations may not apply to you.

This warranty gives you specific legal rights and you may also have other rights which may vary from state to state.

IMPORTANT NOTICE

It is our policy to promote safe delivery of all orders.

This shipment has been thoroughly checked, packed and inspected before leaving our plant and receipt for it in good condition has been received from the carrier. Any loss or damage which occurs to this shipment while enroute is not due to any action or conduct of the manufacturer.

Visible Loss or Damage

If any of the goods called for on the bill of lading or express receipt are damaged or the quantity is short, do not accept them until the freight or express agent makes an appropriate notation on your freight bill or express receipt.

Concealed Loss or Damage

When a shipment has been delivered to you in apparent good condition, but upon opening the

crate or container, loss or damage has taken place while in transit, notify the carrier's agent immediately.

Damage Claims

You must file claims for damage with the carrier. It is the transportation company's responsibility to reimburse you for repair or replacement of goods damaged in shipment. Claims for loss or damage in shipment must not be deducted from the **Ingersoll-Rand** invoice, nor should payment of **Ingersoll-Rand** invoice be withheld awaiting adjustment of such claims as the carrier guarantees safe delivery.

You may return products damaged in shipment to us for repair, which services will be for your account and form your basis for claim against the carrier.

United States Office Locations

For Order Entry and Order Status

Ingersoll-Rand Distribution Center
P.O. Box 618
510 Hester Drive
White House, TN 37188
Phone: (615) 672-0321
Fax: (615) 672-0801

For Technical Support

Ingersoll-Rand Material Handling
P.O. Box 24046
2724 Sixth Avenue South
Seattle, WA 98124-0046
Phone: (206) 624-0466
Fax: (206) 624-6265

Regional Sales Offices

Detroit, MI
23192 Commerce Drive
Farmington Hills, MI 48335
Phone: (810) 476-6677
Fax: (810) 476-6670

Houston, TX
Suite 150
2500 East T.C. Jester
Houston, TX 77008
Phone: (713) 864-3700
Fax: (713) 864-2244

Los Angeles, CA
11909 E. Telegraph Road
Santa Fe Springs, CA 90670
Phone: (310) 948-4189
Fax: (310) 948-1828

Milwaukee, WI
12311 W. Silver Spring Dr.
Milwaukee, WI 53225
Phone: (414) 461-0973
Fax: (414) 461-3639

Philadelphia, PA
900 E. 8th Ave., Suite 103
King of Prussia, PA 19406
Phone: (610) 337-5930
Fax: (610) 337-5912

International Office Locations

Offices and distributors in principal cities throughout the world. Contact the nearest **Ingersoll-Rand** office for the name and address of the distributor in your country or write/fax to:

Ingersoll-Rand Material Handling
P.O. Box 24046
2724 Sixth Avenue South
Seattle, WA 98124-0046
USA
Phone: (206) 624-0466
Fax: (206) 624-6265

Canada National Sales Office Regional Warehouse Toronto, Ontario
51 Worcester Road
Rexdale, Ontario
M9W 4K2
Phone: (416) 675-5611
Fax: (416) 675-6920

Order Desk
Fax: (416) 674-6549

Regional Sales Offices

Calgary, Alberta
44 Harley Road S.E.
Calgary, Alberta
T2V 3K3
Phone: (403) 252-4180
Fax: (403) 252-4462

Edmonton, Alberta
1430 Weber Center
5555 Calgary Trail N.W.
Edmonton, Alberta
T6H 5G8
Phone: (403) 438-5039
Fax: (403) 437-3145

Montreal, Quebec
3501 St. Charles Blvd.
Kirkland, Quebec
H9H 4S3
Phone: (514) 695-9040
Fax: (514) 695-0963

British Columbia
201-6351 Westminster Hwy
Richmond, B. C.
V7C 5C7
Phone: (604) 278-0459
Fax: (604) 278-1254

Latin America Operations Ingersoll-Rand Production Equipment Group
730 N.W. 107 Avenue
Suite 300, Miami, FL
33172-3107
Phone: (305) 559-0500
Fax: (305) 559-7505

Europe, Middle East and Africa

Ingersoll-Rand Material Handling Douai Operations
111, avenue Roger Salengro
59450 Sin Le Noble, France
Phone: (33) 27-93-08-08
Fax: (33) 27-93-08-00

Asia Pacific Operations Ingersoll-Rand (Japan) Ltd.
Shin-Yokohama Square Bldg.
(5th Floor)
2-3-12 Shin-Yokohama,
Kouhoku-Ku, Yokohama-shi,
Kanagawa Pref. 222 Japan
Phone: 81-45-476-7800
Fax: 81-45-476-7806

Russia Ingersoll-Rand Company
World Trade Center
Office 1101
Krasnopresnenskaya Nab. 12
Moscow, Russia 123610

DRUM, BASE AND REDUCTION GEAR ASSEMBLY DRAWING

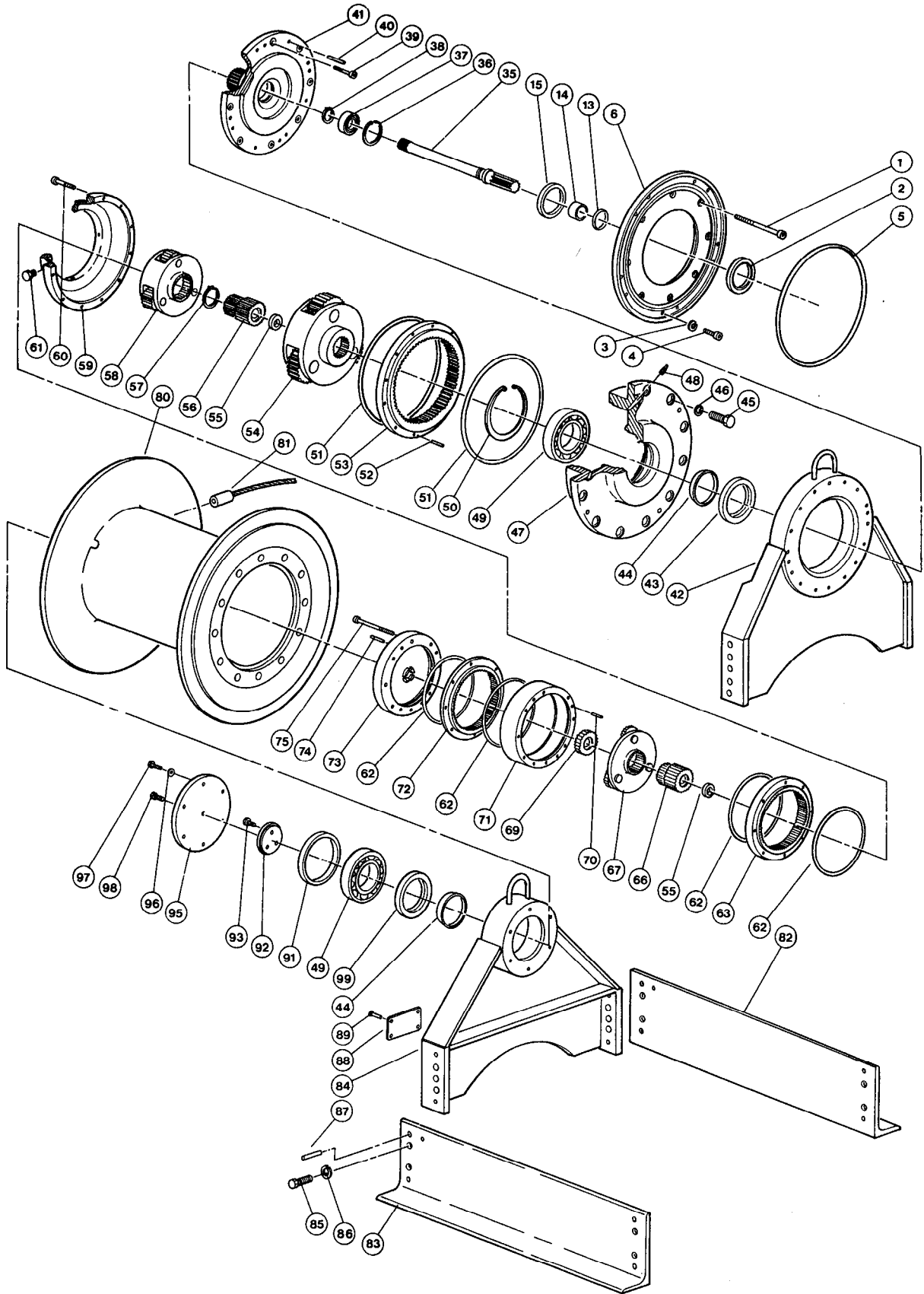

(Dwg. MHTPC0157)

ITEM NO.	DESCRIPTION OF PART	QTY TOTAL	PART NUMBER	ITEM NO.	DESCRIPTION OF PART	QTY TOTAL	PART NUMBER
1	Capscrew	8	50910	59	Input Housing	1	71068589
• 2	Oil Seal	1	51873	60	Capscrew	12	71068605
3	Lockwasher	10	50201	61	Plug	4	71068571
4	Capscrew	10	50197	• 62	O' Ring	4	52149
• 5	O' Ring	1	51459	63	Ring Gear	1	71068548
6	Motor Adapter	1	14227	66	Sun Gear	1	71068530
• 13	O' Ring (Drive Shaft)	1	54462	67	Planetary Assembly	1	71068498
14	Sleeve	1	10598	69	Sun Gear	1	71068662
15	Seal Adapter	1	16354	70	Dowel Pin	4	71068472
35	Shaft	1	10579	71	Spacer	1	71068522
36	Retainer Ring	1	52298	72	Ring Gear	1	71068514
• 37	Bearing	1	51870	73	Cover	1	71068654
38	Retainer Ring	1	51872	74	Dowel Pin	4	71068464
39	Capscrew	8	52380	75	Capscrew	8	71066736
40	Pin, Dowel	12	52334	80	Drum, 24 inch	1	23785-5
41	Drum Shaft	1	14020	81	Wire Rope Anchors:		
42	Upright, Inboard	1	10789		5/8 inch (16 mm)	1	52306
• 43	Seal	1	51464		3/4 inch (19 mm)		52000
* 44	Seal Sleeve	1	51466		7/8 inch (22 mm)		52308
45	Capscrew	12	52829	82	Side Rail (Front - RH)	1	23787-5
46	Lockwasher	12	51012	83	Side Rail (Back - LH)	1	
47	Gear Carrier	1	15418	84	Outboard Upright	1	10790
48	Plug, Fill and Drain	2	51467	85	Capscrew	8	50872
49	Bearing	2	51455	86	Lockwasher	8	50203
50	Retainer Ring	1	71018196	87	Dowel Pin	10	51468
**	Reduction Gear Assembly	1	51721	88	Nameplate	1	71108849
				89	Rivet	4	
• 51	O' Ring	2	71106728	91	Spacer	1	15458
52	Dowel Pin	3	71106710	92	Shaft Retainer	1	15457
53	Ring Gear	1	71068639	93	Capscrew	3	51086
54	Planetary Assembly	1	71068621	95	End Cover	1	15459
• 55	Thrust Bearing	2	71068647	96	Lockwasher	6	50200
56	Sun Gear	1	71068613	97	Capscrew	6	50829
57	Retainer Ring	1	71068597	98	Plug	1	54246
58	Planetary Assembly	1	71068555	• 99	Seal	1	51463

• Recommended spare.

* Seal sleeve, item 44 is no longer used and is not available as a replacement part. For units purchased with seal sleeves requiring replacement contact your Ingersoll-Rand distributor or the factory.

** Reduction Gear Assembly includes item numbers 51 through 75.

DRUM BRAKE ASSEMBLY DRAWING

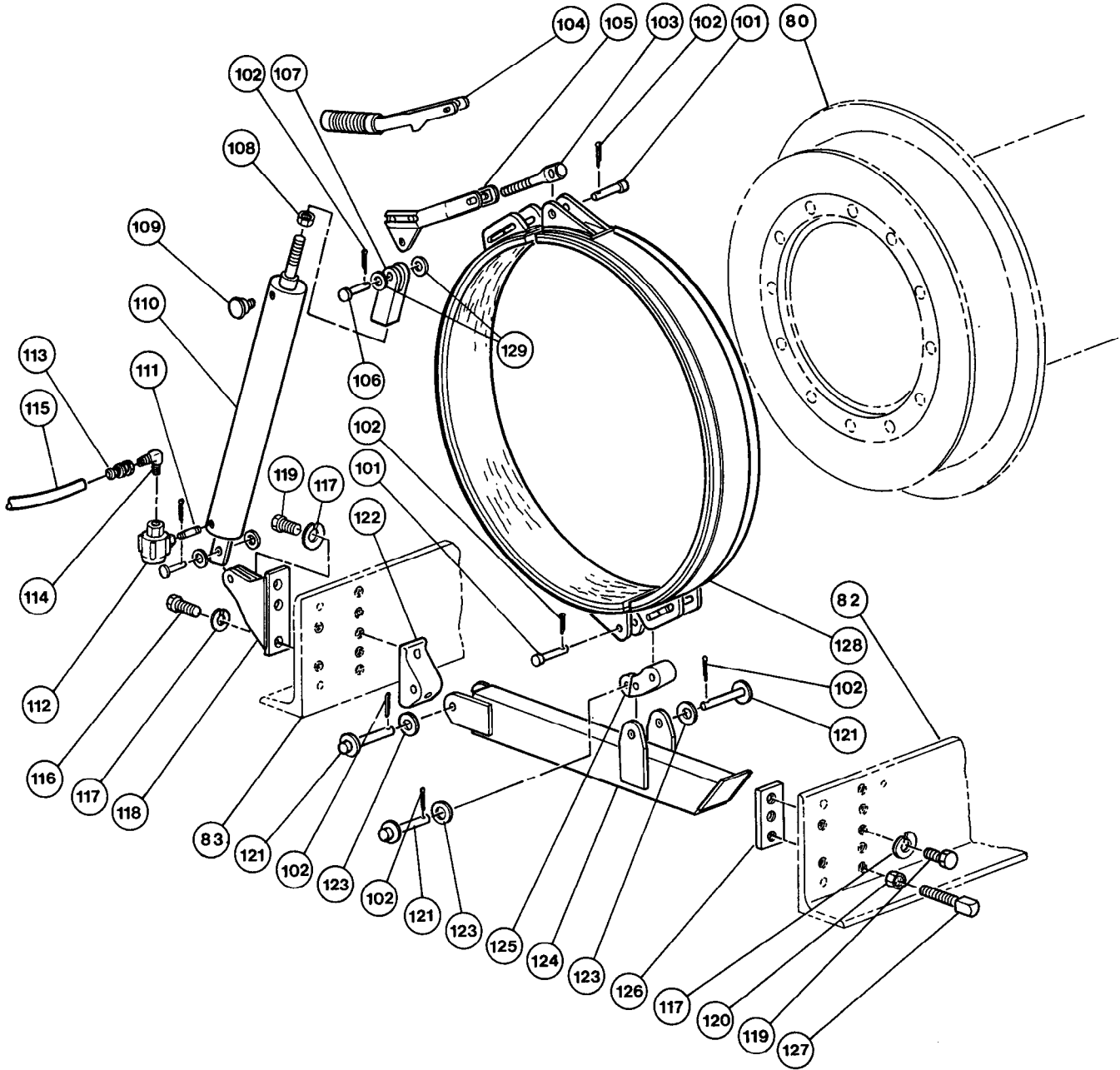

ITEM NO.	DESCRIPTION OF PART	QUANTITY TOTAL	PART NUMBER	
			MANUAL BRAKE	AUTOMATIC BRAKE

Standard 27 inch flange:

80	Drum (12 inch long)	1	Contact factory	
	Drum (16 inch long)		Contact factory	
	Drum (24 inch long)		23785-5	
	Drum (30 inch long)		Contact factory	
	Drum (36 inch long)		Contact factory	

Common Parts:

101	Pin	2	4308-S-1	4308-S-1
102	Cotter Pin	See ()	51937 (5)	51937 (7)
103	Link Stud	1	4115	
104	Brake Lever - Manual Brake	1	4127	---
105	Brake Lever - Automatic Brake	1	---	11349
106	Pin	2	---	8609
107	Clevis	1	---	8586
108	Nut	1	---	50152
109	Breather	1	---	52384
110	Cylinder	1	---	8575
111	Fitting	1	---	52006
* 112	Dump Valve	1	---	51954
113	Fitting	2	---	51029
114	Elbow	1	---	54272
115	Hose	1	---	50923
116	Capscrew	3	---	50873
117	Lockwasher	5	50203	
118	Bracket	1	---	11329
119	Capscrew	3	50850	
120	Nut	See ()	50850 (1)	50850 (2)
121	Pin	3	4307-S	
122	Pivot Bracket	1	10881	
123	Washer	As Req'd	71053904	
124	Arm (27 inch Drum flange)	1	10883	
	Arm (35 inch Drum flange)		10884	
125	Connecting Link	1	10882	
126	Stop Plate	1	10879	
127	Screw, Adjusting	1	71033104	
* 128	Brake Band	1 Set	4103-SET	
	Brake Band Lining Kit	1 Kit	4103-BLK	
129	Washer	2	52914	
*	Recommended spare.			

MOTOR ASSEMBLY DRAWING

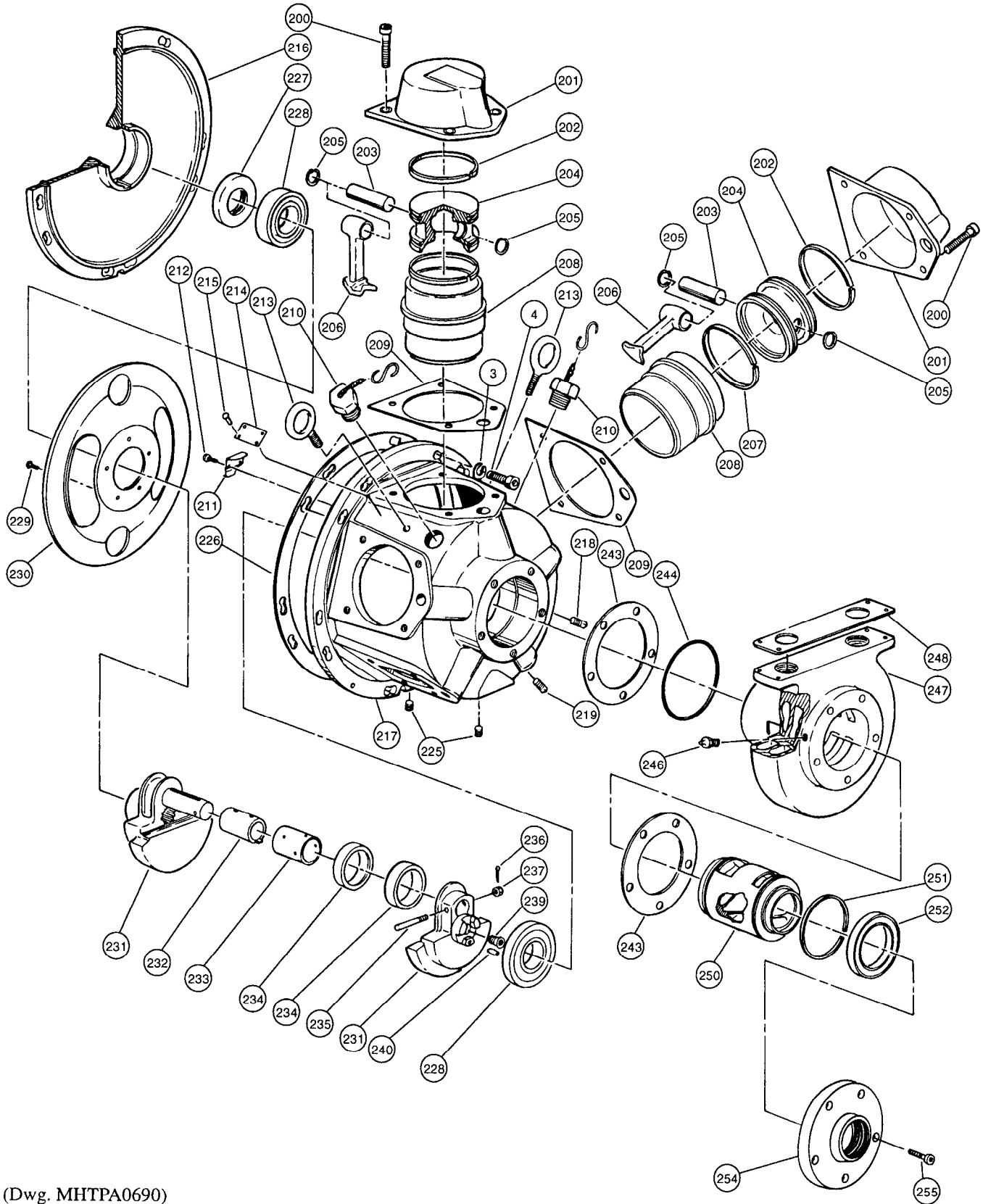

(Dwg. MHTPA0690)

MOTOR ASSEMBLY PARTS LIST

ITEM NO.	DESCRIPTION OF PART	QTY TOTAL	PART NUMBER	ITEM NO.	DESCRIPTION OF PART	QTY TOTAL	PART NUMBER
**	Motor Assembly	1	K5B-546L	• 226	Gasket	1	K5B-592
3	Lockwasher	10	50201	• 227	Oil Seal	1	K5B-270
4	Capscrew	10	14227	228	Crank Bearing	2	K5B-518
200	Capscrew	20	52317	* 229	Button Head Screw	5	*
201	Cylinder Head	5	K5B-H505	* 230	Oil Slinger	1	*
• 202	Compression Ring	1 Set	K5B546-KRING	231	Crank Assembly	1	K5B-A516
203	Wrist Pin	5	HU-514A	232	Sleeve	1	K5B-519
* 204	Piston	5	*	233	Bushing	1	K5B-511
205	Retainer Ring	10	902A45-632	234	Connecting Rod Ring	2	K5B-510
206	Connecting Rod	5	K5B-509	235	Lock Pin	1	HU-K520
• 207	Oil Ring	5	Order Item 202	236	Cotter Pin	1	D02-524
208	Cylinder Liner	5	K5B-L505-47	237	Pin Nut	1	D02-394
• 209	Head Gasket	1 Set	K5B-507-5	239	Flat Head Screw	1	I39A2A266
210	Vent Cap Assembly	2	K5B-A303	240	Roll Pin	1	WF171-15
211	Baffle	2	K5B-528	• 243	Gasket	2	K5B-928
212	Screw	4	J-376	• 244	'O' Ring	1	20A11CM248
213	Eye Bolt	2	KU-888	246	Grease Fitting	1	23-188
214	Nameplate	1	K5B-301	247	Rotary Valve Housing	1	K5B-545
215	Drive Screw	4	R4K-302-12	• 248	Gasket	1	K5B-547
216	Mounting Flange	1	K5B-502	250	Rotary Valve	1	K5B-526
217	Motor Housing	1	K5B-501	• 251	Seal Ring	1	K5B-607
218	Pipe Plug (Oil level)	1	ROH-377	• 252	Bearing	1	K5B-97
219	Pipe Plug	1	TC-368	254	Exhaust Flange	1	K5B-276
225	Pipe Plug (Drain)	2	GA57-95	255	Capscrew	5	51471

• Recommended spare.

* Parts not sold separately. Refer to the "Motor Assembly Kit List."

** Motor Assembly consists of items 200 through 255.

Motor Assembly Kit List:

ITEM NO.	DESCRIPTION OF PART	QTY TOTAL	PART NUMBER
231	Crank Assembly (Includes items 206 and 228 through 237)	1	K5B-A516
261	Piston Assembly (Includes items 202 through 205 and item 207)	1	K5B-A513-47
262	Cylinder Assembly (Includes items 201 and 208)	1	K5B-A505-47

LIMIT SWITCH ASSEMBLY DRAWING

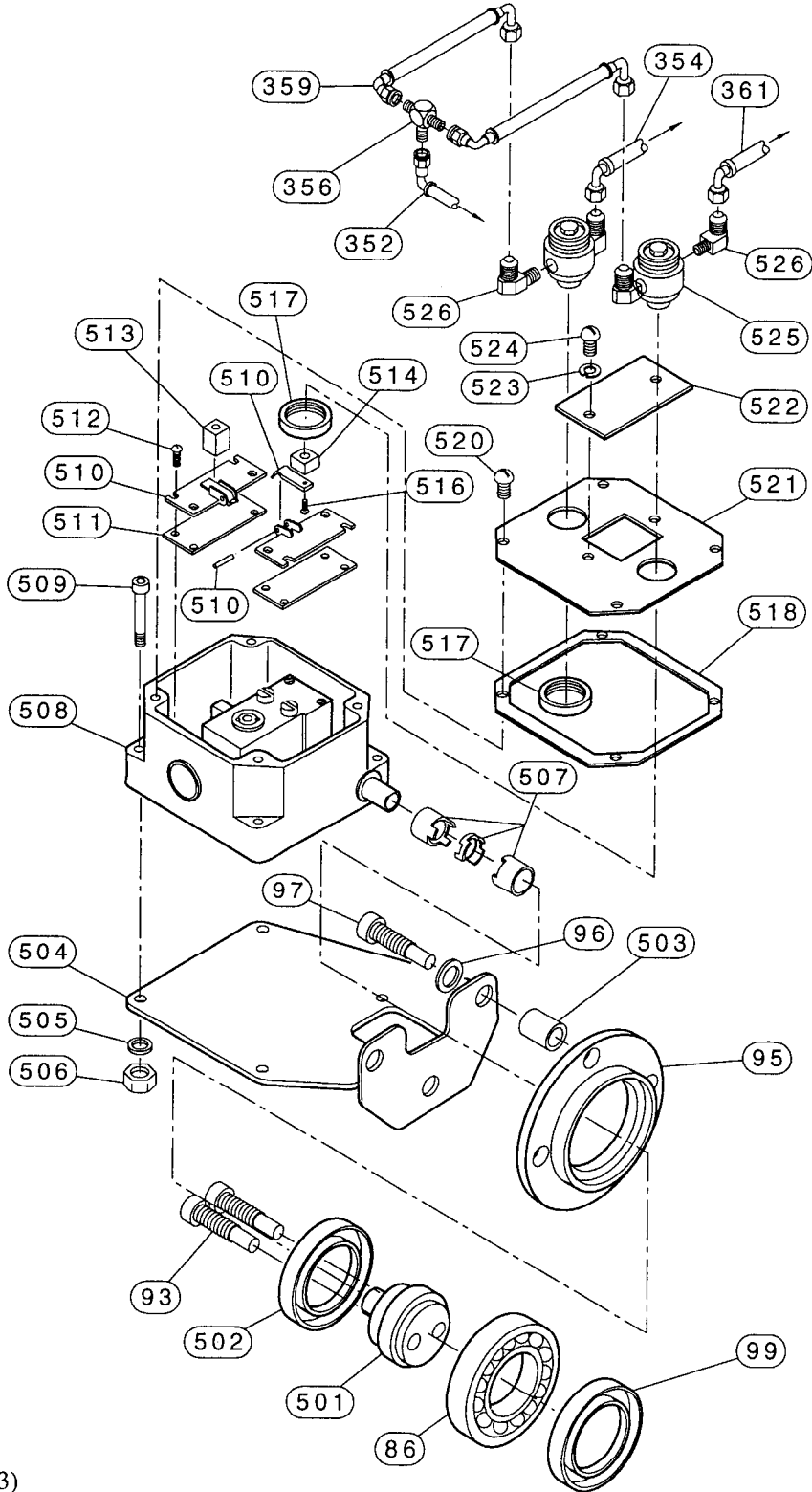

(Dwg. MHTPB0633)

LIMIT SWITCH ASSEMBLY PARTS LIST

ITEM NO.	DESCRIPTION OF PART	QUANTITY TOTAL	PART NUMBER	
86	Bearing	2	51797	
93	Capscrews	2	71030787	
95	End Cover	1	19233	
96	Lockwasher	3	50200	
97	Capscrew	3	51769	
99	Seal	2	51474	
352	Hose Assembly	Specify Length in Feet	50923	
354	Hose Assembly			
356	Fitting, Tee	1		
359	Hose Assembly	Specify Length in Feet	50923	
361	Hose Assembly			
501	Retainer	1	19232	
502	Seal	1	71054688	
503	Spacer	3	14998-7	
504	Bracket, Limit Switch	1	11501	
505	Lockwasher	4	52909	
506	Nut	4	54142	
507	Coupling Assembly	1	52381	
508	Limit Switch Assembly	1	19578-1	
509	Capscrew	4	54493	
510	Lever Assembly	2	Order Item 508 Limit Switch Assembly	
511	Plate	2		
512	Capscrew	8		
513	Block, Tall	1		
514	Block, Short	1		
516	Capscrew	2		
517	Locking Ring	2		
518	Gasket	1		
520	Capscrew	4		
521	Cover Plate	1		
522	Access Plate	1		
523	Lockwasher	2		
524	Capscrew	2		
525	Valve	4		51756
526	Fitting, 90	8		51281

PILOT AIR CONTROL VALVE ASSEMBLY DRAWING AND PARTS LIST

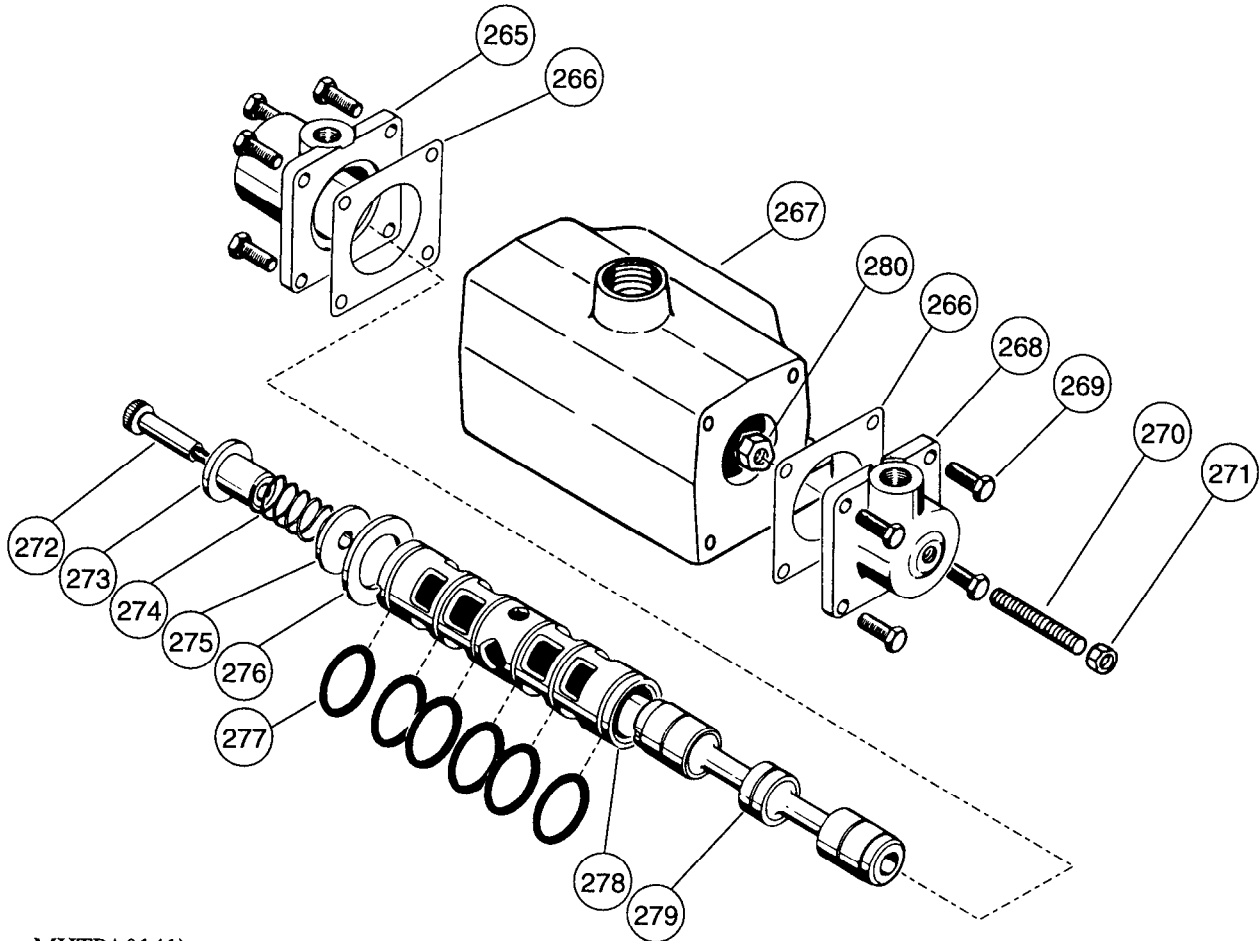

(Dwg. MHTPA0141)

ITEM NO.	DESCRIPTION OF PART	QTY TOTAL	PART NUMBER
355	Valve Assembly Includes items 265 through 280	1	20991
265	End Cap	1	52241
• 266	Gasket	2	52457
267	Valve Body	1	Not sold separately, order item 355
268	End Cap (Inlet Side)	1	11778
269	Capscrew	8	52234
270	Adjusting Screw	1	71083968
271	Nut	1	52265
272	Shoulder Screw	1	817-002
273	Guide	1	52233
274	Spring	1	52240
275	Washer	1	52239
276	Spacer	1	52238
• 277	O' Ring	6	51632
278	Valve Sleeve	1	Not sold separately, order item 355
279	Valve Spool	1	Not sold separately, order item 355
280	Stop	1	11777

• Recommended spare.

PILOT AIR VALVE PLUMBING ASSEMBLY DRAWING

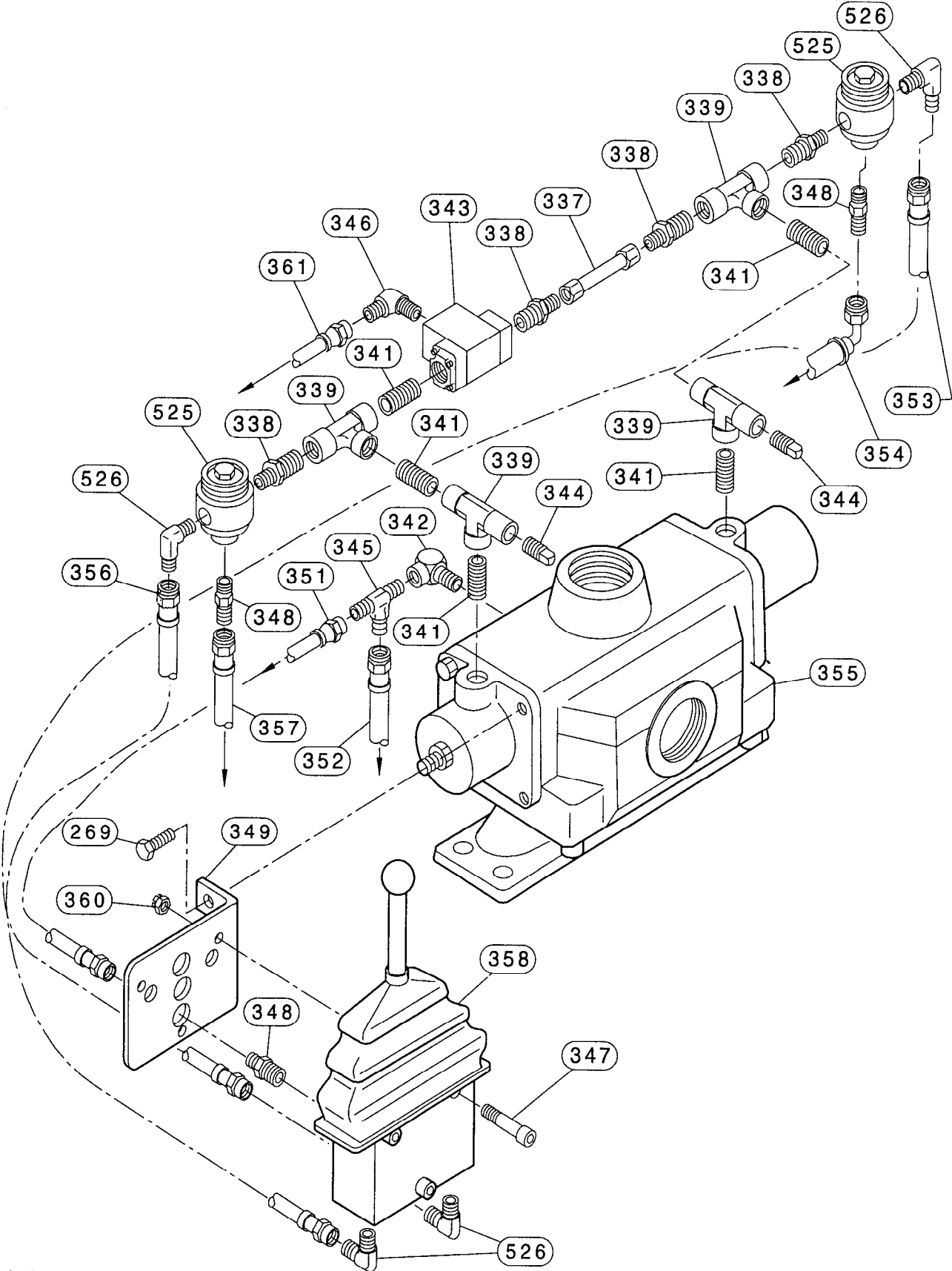

(Dwg. MHTPB0632)

PILOT AIR VALVE PLUMBING ASSEMBLY PARTS LIST

ITEM NO.	DESCRIPTION OF PART	QTY TOTAL	PART NUMBER
269	Capscrew	8	52234
337	Tube Assembly	1	
338	Fitting	4	51814
339	Fitting, Tee	4	54678
341	Fitting	5	51034
342	Fitting, Elbow	1	71034714
343	Valve	1	50277
344	Fitting, Plug	2	50822
345	Fitting, Tee	1	71063374
346	Fitting, Elbow	1	52182
347	Capscrew	3	71053763
348	Fitting	3	52092
349	Bracket	1	20231
351	Hose Assembly	Specify Length in Feet	50923
352	Hose Assembly		
353	Hose Assembly		
354	Hose Assembly		
355	Valve Assembly	1	20991
356	Hose Assembly	Specify Length (Feet)	50923
357	Hose Assembly		
358	Throttle Valve Assembly	1	71149389
360	Nut	3	54171
525	Valve	4	51756
526	Fitting, Elbow	8	51281

LINE SPEED MONITOR ASSEMBLY DRAWING AND PARTS LIST

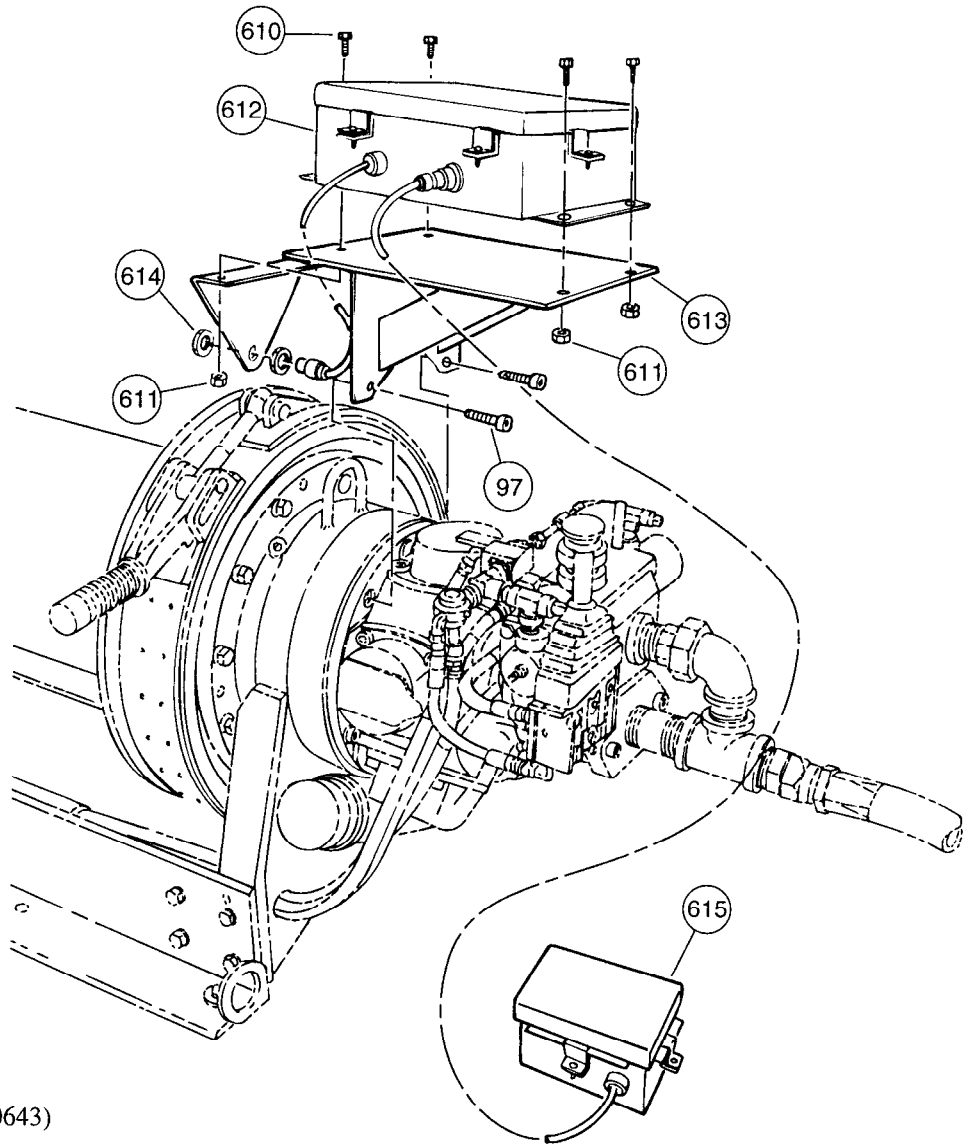

(Dwg. MHTPA0643)

ITEM NO.	DESCRIPTION OF PART	QUANTITY TOTAL	PART NUMBER
97	Capscrew	5	50829
610	Capscrew	4	53374
611	Nut	4	53390
612	Line Speed Monitor	1	LSM1
613	Bracket, Monitor	1	23768
614	Lock Nut	2	Refer to Item 612, provided with sensor
615	Monitor Battery Charger	1	BC01
616	Bracket, Sensor	1	23823

MUFFLER ASSEMBLY DRAWING AND PARTS LIST

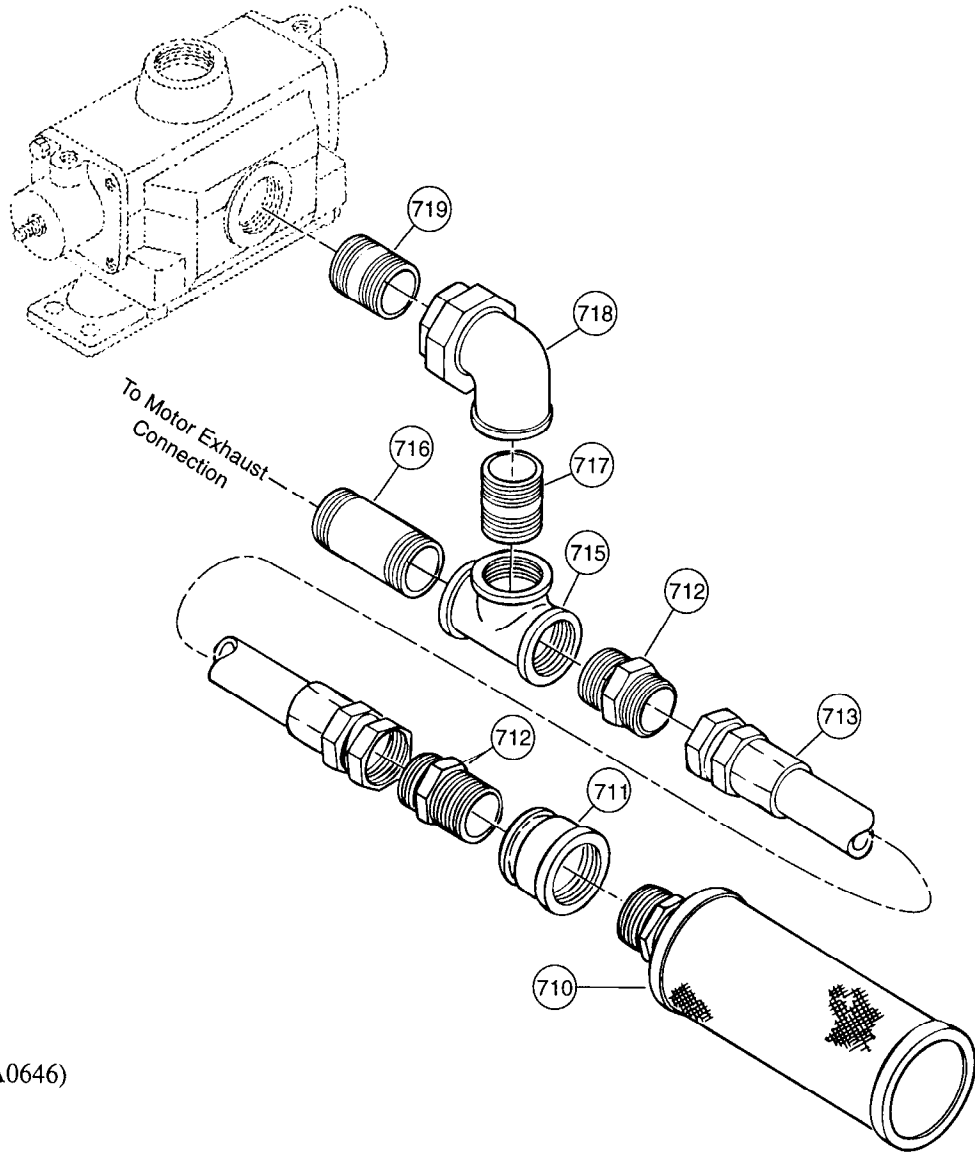

(Dwg. MHTPA0646)

ITEM NO.	DESCRIPTION OF PART	QUANTITY TOTAL	PART NUMBER
355	Valve Assembly	1	20991
710	Muffler	1	50594
711	Fitting, Pipe	1	71144976
712	Fitting	2	52076
713	Hose Assembly	10 feet	Contact factory
714	Fitting, Pipe	1	71144984
715	Fitting, Pipe	1	71068860
716	Fitting, Pipe	1	71145056
717	Fitting, Pipe	1	71144992
719	Fitting, Pipe	1	50933

ACCESSORIES PARTS LIST

DESCRIPTION OF ACCESSORY	ACCESSORY PART NUMBER
Lubricant	LUBRI-LINK-GREEN
Touch-up Paint	FAP-237Y

WINCH LABEL AND TAG PARTS LIST

ITEM NO.	DESCRIPTION OF LABEL	QTY TOTAL	PART NUMBER	ITEM NO.	DESCRIPTION OF LABEL	QTY TOTAL	PART NUMBER
• 601	Warning	1	71124895	612	IR Logo (small)	2	71106322
• 602	Caution Tag	1	71107148	• 613	Notice	1	71150023
• 603	Overwind	2	71109516	• 614	Owner's Manual	1	71149454
604	IR Siderail Logo	1	71106272	• 615	Limit Switch Adjust	1	71149454
605	Product	1	71111785	616	To Sensor Input	1	71149439
• 606	Nameplate	1	71108849	617	Battery Charger Input	1	71149421
607	Nameplate Rivet	4	71028849	618	Ground Connection	1	71149447
608	Exhaust	1	71042196	619	Line Speed Monitor	1	71149405
609	Oil	1	71043616	620	Battery Charger	1	71149413
610	Air Supply	1	71046395				

• At a minimum, and to ensure the winch attached safety labels are in place, replace these labels if they are lost or damaged.