

IMPORTANT INFORMATION:

- A copy of our “Safe Operating Practices” Manuals are always available free of charge either by downloading it from our Technical Publications website @ www.airwinch.com or by contacting the Factory at (800) 866-5457 for North America and (206) 624-0466 for International. The Safe Operating Practices manual must be read prior to anyone operating a **Ingersoll-Rand** winch or hoist. The manual form numbers are as follows:

“Safe Operating Practices Non-Man Rider™ Winches” Manual, Form No. MHD56250

“Safe Operating Practices for Man Rider™ Winches” Manual, Form No. MHD56251

“Safe Operating Practices for Pneumatic, Hydraulic and Electric Hoists” Manual, Form No. MHD56295

- Available winch options may require additional supplements to the basic winch manual.
- For Man Rider™ winches ensure a copy of the Man Rider™ supplement is made available to the operator prior to winch operation.

Winch Man Rider™ Supplements:

Model:	Publication No.
FA2, FA2.5, FH2, FH2.5	MHD56046
FA5	MHD56042 and MHD56220
FA10	MHD56252
FA2.5A	MHD56236
FA2B and HU40A	MHD56207
FH10MR	MHD56212
Fulcrum Electric	MHD56277
LS500HLP/ LS1000HLP	SAM0004

Model:	Publication No.
LS500RLP	SAM0011
LS1000RLP	SAM0012
LS150RLP	SAM0082
LS150RLP/500/ 1000	SAM0115
LS150RLP and LS150PLP-PH	SAM0120
LS500RLP-E	SAM0122
LS150RLP- DP5M-F	SAM0184
LS150HLP	SAM0222

- We strongly recommend that ALL maintenance on **Ingersoll-Rand** equipment be carried out by personnel certified by **Ingersoll-Rand**, or by **Ingersoll-Rand** Authorized Service Centers.
- Contact the Factory if in doubt about installation, operation, inspection and maintenance instructions.
- Use only Genuine **Ingersoll-Rand** parts when maintaining or repairing a winch, hoist or any component of a winch or hoist.
- ANSI / ASME recommends that a winch or hoist (or any components of a winch or hoist) that has been repaired be tested prior to being placed into service:
 - * **Winches** - ANSI / ASME B30.7 (BASE MOUNTED DRUM HOISTS) Refer to section 7.2.2 - Testing.
 - * **Hoists** - ANSI / ASME B30.16 (OVERHEAD HOISTS - UNDERHUNG) Refer to section 16.2.2 - Testing.

force **5**TM **AIR WINCHES**

MODEL FA7 AND FA7T PARTS, OPERATION AND MAINTENANCE MANUAL

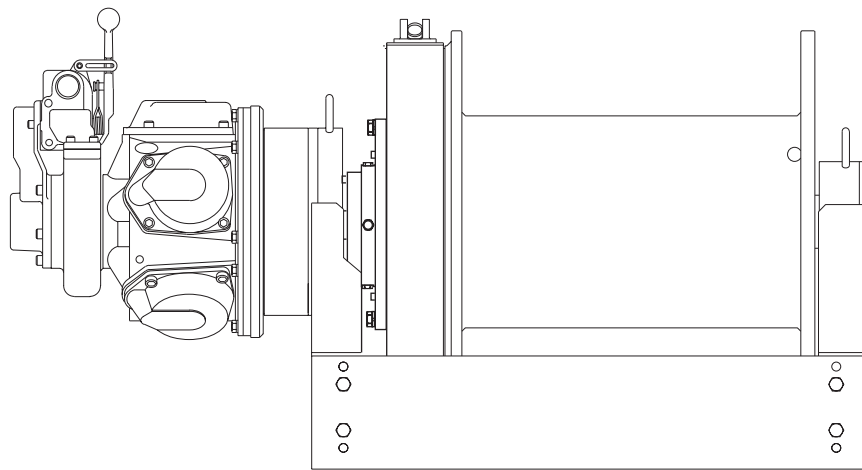

(Dwg. MHP0897)

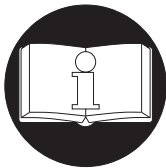

READ THIS MANUAL BEFORE USING THESE PRODUCTS. This manual contains important safety, installation, operation and maintenance information. Make this manual available to all persons responsible for the installation, operation and maintenance of these products.

⚠ WARNING

Do not use this winch for lifting, supporting, or transporting people or lifting or supporting loads over people.

Always operate, inspect and maintain this winch in accordance with American National Standards Institute Safety Code (ASME B30.7) and any other applicable safety codes and regulations.

Refer all communications to the nearest Ingersoll-Rand Material Handling Office or Distributor.

TABLE OF CONTENTS

Description	Page No.
Safety Information	
Danger, Caution, Warning and Notice	3
Safe Operating Instructions	4
Warning Label.....	4
Specifications	
Model Code.....	5
General Specifications	6
Performance Graphs	6
Description of Operation	7
Installation	
Mounting.....	8
Wire Rope	9
Air Supply.....	10
Initial Operating Checks	12
Operation	
Controls.....	13
Emergency Stop	14
Brakes	15
Drum Locking Pin	15
Lubrication	
Recommended Lubricants	16
Motor	16
Wire Rope.....	17
Reduction Gear Assembly	17
Disc Brake.....	17
Seals and Bearings	18
Drum Locking Pin	18
Inspection	
Records and Reports.....	19
Frequent Inspection.....	19
Periodic Inspection	20
Winches not in Regular Use	20
Inspection and Maintenance Report	21
Troubleshooting	
Troubleshooting Chart	22
Maintenance	
Maintenance Intervals.....	24
Adjustments	25
Disassembly Instructions	27
Cleaning, Inspection and Repair.....	30
Assembly Instructions.....	31
Testing.....	34
Parts Information	
FA7 Winch Assembly Drawings Reference Diagram.....	36
FA7 Winch Drawings and Parts Lists Table of Contents	37
Common Parts List	72
Return Goods Policy.....	74
Warranty	75
Office Locations	76

SAFETY INFORMATION

This manual provides important information for all personnel involved with the safe installation, operation and proper maintenance of this product. Even if you feel you are familiar with this or similar equipment, you should read this manual before operating the winch.

Danger, Warning, Caution and Notice

Throughout this manual there are steps and procedures which, if not followed, may result in an injury. The following signal words are used to identify the level of potential hazard.

DANGER

Danger is used to indicate the presence of a hazard which *will* cause *severe* injury, death, or substantial property damage if the warning is ignored.

WARNING

Warning is used to indicate the presence of a hazard which *can* cause *severe* injury, death, or substantial property damage if the warning is ignored.

CAUTION

Caution is used to indicate the presence of a hazard which *will* or *can* cause injury or property damage if the warning is ignored.

NOTICE

Notice is used to notify people of installation, operation, or maintenance information which is important but not hazard-related.

Safety Summary

WARNING

- **Do not use this winch for lifting, supporting, or transporting people or lifting or supporting loads over people.**
- **The supporting structures and load-attaching devices used in conjunction with this winch must provide an adequate safety factor to handle the rated load, plus the weight of the winch and attached equipment. This is the customer's responsibility. If in doubt, consult a registered structural engineer.**

Ingersoll-Rand Material Handling winches are manufactured in accordance with the latest ASME B30.7 standards.

The National Safety Council, Accident Prevention Manual for Industrial Operations, Eighth Edition and other recognized safety sources make a common point: Employees who work near suspended loads or assist in hooking on or arranging a load should be instructed to keep out from under the load. From a safety standpoint, one factor is paramount: conduct all lifting or pulling operations in such a manner that if there were an equipment failure, no personnel would be injured. This means keep out from under a raised load and keep out of the line of force of any load.

The Occupational Safety and Health Act of 1970 generally places the burden of compliance with the user, not the manufacturer. Many OSHA requirements are not concerned or connected with the manufactured product but are, rather, associated with the final installation. It is the owner's and user's responsibility to determine the suitability of a product for any particular use. It is recommended that all applicable industry, trade association, federal, state and local regulations be checked. Read all operating instructions and warnings before operation.

Rigging: It is the responsibility of the operator to exercise caution, use common sense and be familiar with proper rigging techniques. Refer to ASME B30.9 for rigging information, American National Standards Institute, 1430 Broadway, New York, NY 10018.

This manual has been produced by **Ingersoll-Rand** to provide dealers, mechanics, operators and company personnel with the information required to install, operate, maintain and repair the products described herein.

It is extremely important that mechanics and operators be familiar with the servicing procedures of these products, or like or similar products, and are physically capable of conducting the procedures. These personnel shall have a general working knowledge that includes:

1. Proper and safe use and application of mechanics common hand tools as well as special **Ingersoll-Rand** or recommended tools.
2. Safety procedures, precautions and work habits established by accepted industry standards.

Ingersoll-Rand cannot know of, or provide all the procedures by which product operations or repairs may be conducted and the hazards and/or results of each method. If operation or maintenance procedures not specifically recommended by the manufacturer are conducted, it must be ensured that product safety is not endangered by the actions taken. If unsure of an operation or maintenance procedure or step, personnel should place the product in a safe condition and contact supervisors and/or the factory for technical assistance.

SAFE OPERATING INSTRUCTIONS

The following warnings and operating instructions have been adapted in part from American National (Safety) Standard ASME B30.7 and are intended to avoid unsafe operating practices which might lead to injury or property damage.

Ingersoll-Rand recognizes that most companies who use winches have a safety program in force at their facility. In the event that some conflict exists between a rule set forth in this publication and a similar rule already set by an individual company, the more stringent of the two should take precedence.

Safe Operating Instructions are provided to make an operator aware of dangerous practices to avoid and are not necessarily limited to the following list. Refer to specific sections in the manual for additional safety information.

1. Only allow personnel trained in safety and operation of this product to operate and maintain this winch.
2. Only operate a winch if you are physically fit to do so.
3. When a **“DO NOT OPERATE”** sign is placed on the winch, or controls, do not operate winch until sign has been removed by designated personnel.
4. Before each shift, check the winch for wear and damage. Never use a winch that inspection indicates is worn or damaged.
5. Never lift a load greater than rated capacity of the winch. See labels attached to winch or refer to **“SPECIFICATIONS”** section.
6. Keep hands, clothing, etc., clear of moving parts.
7. Never place your hand in the throat area of a hook or near wire rope spooling onto or off of winch drum.
8. Always rig loads properly and carefully.
9. Be certain load is properly seated in saddle of the hook. Do not support load on tip of hook.
10. Do not **“side pull”** or **“yard”**.
11. Always ensure that you, and all other people, are clear of the path of the load. Do not lift a load over people.
12. Never use winch for lifting or lowering people, and never allow anyone to stand on a suspended load.
13. Ease slack out of wire rope when starting a lift or pull. Do not jerk the load.
14. Do not swing a suspended load.
15. Do not leave a suspended load unattended.
16. Never operate a winch with twisted, kinked or damaged wire rope.
17. Pay attention to load at all times when operating winch.
18. Never use wire rope as a sling.
19. After use, or when in a non-operational mode, winch should be secured against unauthorized and unwarranted use.

WARNING LABEL

Each unit is shipped from the factory with the warning label shown. If the label is not attached to your unit, order a new label and install it. Refer to the parts list for the part number. Label is shown smaller than actual size.

⚠ WARNING

Failure to follow these warnings may result in death, severe injury or property damage:

- Do not operate this winch before reading operation and maintenance manual. 
- Do not lift people or loads over people.
- Do not lift more than rated load.
- Do not allow less than three wraps of wire rope to remain on drum at all times.
- Do not operate a damaged or malfunctioning winch.
- Do not remove or obscure warning labels.

Read the latest edition of ASME B30.7.
Comply with other federal, state and local rules.

P/N 71060529/C
for winches

INGERSOLL-RAND
MATERIAL HANDLING

SPECIFICATIONS

Model Code Explanation

Example: FA7-36MK320P

FA7 - 24 M K 320 P

Series (Capacity)

FA7 Air Powered Winch (7 metric ton / 15,400 lbs.)

FA7T and FA57TPL Air Powered Winch (4.6 metric ton / 10,200 lbs.)

FA7TGL Air Powered Winch (1.5 metric tons / 3,400 lbs)

Drum Flange Height:

- = Standard flange: 30 inch (760 mm) diameter

T = Tall flange: 36 inch (915 mm) diameter

TGL = Guideline: 42 inch (1065 mm) diameter

TPL = Podline: 42 inch (1065 mm) diameter

Drum Length (Distance between drum flanges):

24 = 24 inch (610 mm) Standard

30 = 30 inch (760 mm)

36 = 36 inch (915 mm) Tall Flange Winch only

42 = 42 inch (1065 mm) [Tall flange model only]

55 = 55 inch (1397 mm)

Drum Brake:

A = Automatic Drum Brake

M = Manual Drum Brake

X = None

Disc Brake:

K = Automatic Disc Brake

X = None

Control:

1 = Winch mounted lever throttle. (Standard)

* 2XX = Remote full flow lever throttle (XX = Specify hose length (feet). Maximum 20 ft. (6 metres))

* 3XX = Remote pilot pendant throttle (XX = Specify hose length (feet). Maximum 50 ft. (15 metres))

* 4XX = Remote pilot lever throttle (XX = Specify length (feet). Maximum 50 ft. (15 metres))

Options: **

7 = Drum Grooving (Number = wire rope size in sixteenths, e.g. 7/16 inch) †

** C = Low Temperature Components; specify -10° C (14° F) or -20° C (-4° F)

D = Drum Divider Flange and additional wire rope anchor †

G = Drum Guard

L = Drum Locking Pin

** M1 = Material Traceability (typical material results) ††

** M2 = Material Traceability (actual material results) ††

** M3 = Material Traceability (actual material results for these parts in finished, as-delivered condition) ††

N = Type Approval – Specify:

A = American Bureau of Shipping (ABS); N = Det Norske Veritas (DNV); R = Lloyd's Register of Shipping (LRS)

P = Marine grade corrosion preventative finish

Q = Special paint

U = Underwound wire rope operation †

T = Tensioning Manifold

W = Witness; please specify **

S = Rotary Limit Switch (upper and lower)

X = Testing; please specify

Z = Sand Blast and Carbozinc primer only

-E = Compliance with European Machinery Directive (includes Emergency Stop and Overload Protection)

Notes:

* Remote throttles are provided with 6 feet (2 metres) of hose. Specify hose lengths greater than 6 feet. For lengths greater than 20 ft. (6 metres) with the Remote Full Flow Throttle, or 50 ft. (15 metres) with the Remote Pilot Lever and Remote Pilot Pendant Throttles contact your **Ingersoll-Rand** distributor or the factory for control acceptability. Metric lengths are provided for reference only, order lengths in feet.

** Documentation, witness testing and material traceability available; must be requested at time of order. Specify options or contact the factory or your nearest **Ingersoll-Rand** distributor for information.

† Not covered in this manual.

†† Refer to 'Traceability' on page 7 for a description of the differences between M1, M2 and M3.

General Specifications:		Model			
		FA7		FA7T	
Air System	Rated Operating Pressure	90 psig (6.3 bar)			
	Air Consumption (at rated pressure and load)	750 scfm	21.5 cu.m/min	750 scfm	21.5 cu.m/min
Rated Performance (at rated pressure / volume)	Full Drum Line Pull	15,400 lbs	6985 kgs	10,200	4627 kgs
	Mid Drum Line Speed	45 fpm	14 m/min	50 fpm	15 m/min
	Max Stall Pull - 1st Layer	36,000 lbs	16329 kgs	36,000 lbs	16329 kgs
	FA7-24MX1 Net Weight	1,775 lbs	805 kgs	---	---
	FA7T-24MX1 Net Weight	---	---	2,215 lbs	1005 kgs
Air Motor Pipe Inlet Size		1.25 inch	32 mm	1.25 inch	32 mm
Minimum Air System Hose Size		1.5 inch	38 mm	1.5 inch	38 mm
Drum Barrel Diameter		16 inches	406 mm	16 inches	406 mm
* Drum Wire Rope Storage Capacity (feet / metres) (Based on full drum storage less 1/2 inch (13 mm) of clear flange above top layer) meets ASME B30.7	Drum Length (inches)	Wire Rope Diameter			
		0.75 inch	18 mm	0.75 inch	18 mm
	24 (Standard)	1640 ft	510 m	2669 ft	829 m
	30	2063 ft	641 m	3358 ft	1044 m
	36	2486 ft	773 m	4047 ft	1258 m
	42 (Tall Flange only)	---	---	4735 ft	1471 m
	55	3826 ft	1189 m	6228 ft	1935 m
		0.825 inch	20 mm	0.825 inch	20 mm
	24 (Standard)	1059 ft	329 m	1917 ft	596 m
	30	1333 ft	414 m	2414 ft	750 m
	36	1608 ft	500 m	2912 ft	905 m
	42 (Tall Flange only)	---	---	3409 ft	1059 m
	55	2478 ft	770 m	4486 ft	1394 m
		1 inch	24 mm	1 inch	24 mm
	24 (Standard)	786 ft	244 m	1538 ft	478 m
	30	991 ft	308 m	1940 ft	603 m
	36	1196 ft	372 m	2341 ft	727 m
	42 (Tall Flange only)	---	---	2742 ft	852 m
	55	1845 ft	573 m	3612 ft	1122 m

* Wire rope storage capacity based on wire rope top layer located a minimum of 1/2 inch (13 mm) below drum flange and meets ASME B30.7. The wire rope storage capacities listed may vary from figures stated elsewhere.

Performance Graphs

FA7 Winch

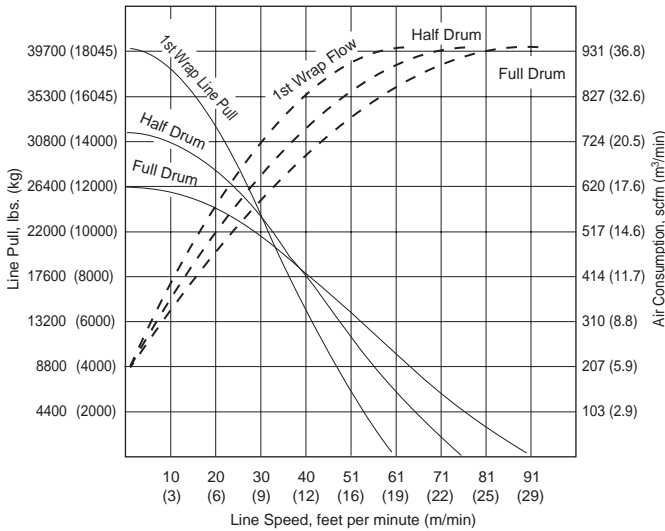

FA7T Winch

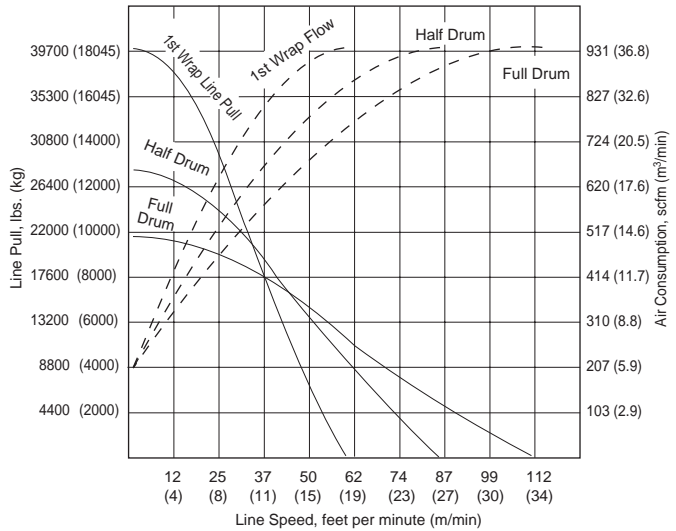

FA7TPL

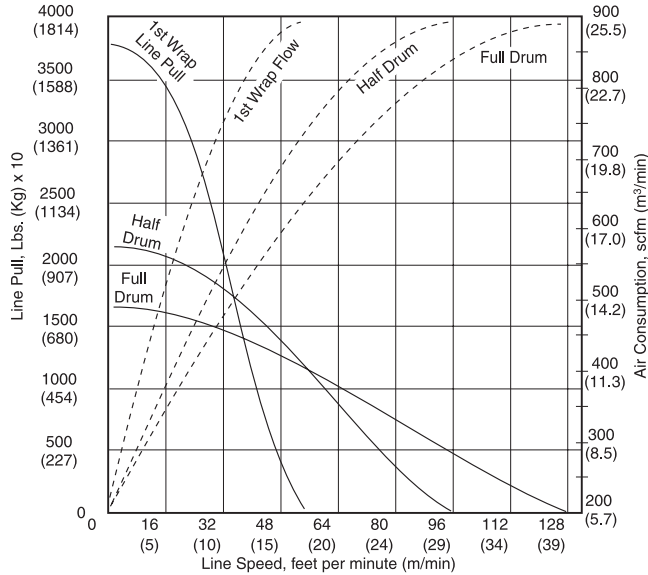

FA7TGL

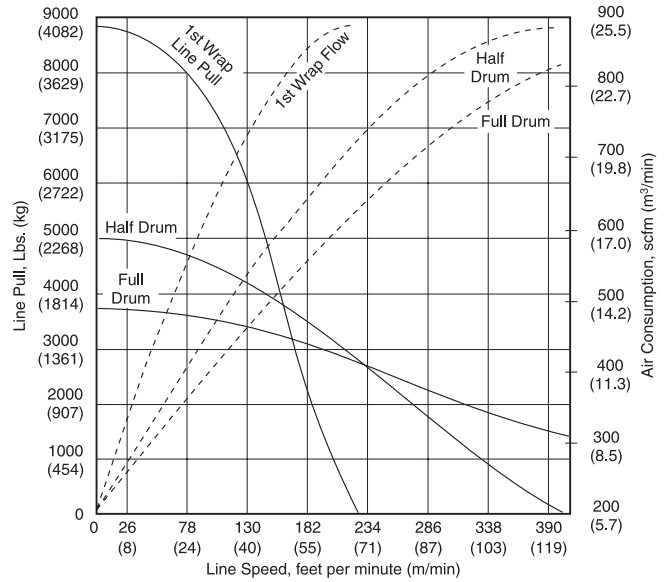

(Dwg. MHP1992)

Description of Operation

FA7 winches are air powered, planetary geared units designed for lifting and pulling applications. **FA7** winches are supplied with either an internal automatic disc brake, a manual or automatic externally mounted drum band brake, or a combination of both.

The output from an externally mounted piston air motor is transmitted through a coupling and shaft to the planetary reduction gear assembly.

The output from the planetary reduction gear assembly is connected to the wire rope drum through the output shaft.

FA7 winches can be provided with an optional disc brake assembly consisting of friction plates splined to a hub which in turn is connected to the drive shaft from the air motor. The brake friction plates are clamped to the drum shaft through a spring applied piston. The brake remains applied until the winch payout or haul-in occurs. Air is introduced into brake piston chamber which is formed between brake piston and brake housing and causes brake piston to retract, compressing brake springs and releasing friction plates allowing motor shaft to rotate. A power failure or sudden loss of air will immediately cause spring applied brake to engage.

The drum band brake operates by applying a friction force between drum brake and winch drum. The manual brake requires an operator to engage and disengage brake using a lever located on top of brake band. The automatic drum band brake operation is similar to disc brake operation; they are both fully disengaged in the haul-in and payout direction.

Traceability

Load bearing parts are documented to provide traceability. Documentation includes chemical and physical properties of raw material, heat treating, hardening, tensile and charpy tests as required for the part.

Units with M1, M2 or M3 in the model code have traceable load bearing components.

M1–Material Traceability certificates according to EN 10204 (Ex DIN 50049) 2.2 on load bearing parts. Conformity documents affirm (by the manufacturer) that parts are in compliance with the requirements of the order based on non-specific inspection and testing (i.e. results are typical material properties for these parts).

M2–Material Traceability certificates according to EN 10204 (Ex DIN 50049) 3.1b on load bearing parts. Conformity documents affirm (by a department independent of the manufacturing department) that the actual parts are in compliance with the requirements of the order based on specific inspection and testing (i.e. results are actual material properties for these parts).

M3–Material Traceability certificates according to EN 10204 (Ex DIN 50049) 3.1b on load bearing parts. Conformity documents affirm (by a department independent of the manufacturing department) that the actual parts used in the product are in compliance with the order based on specific inspection and testing (i.e. results are actual material properties for these parts in a finished, as delivered condition).

Components with part numbers ending in CH are charpy parts for use under extreme cold conditions. Traceability requirements must be stated when reordering these parts for continued certification.

INSTALLATION

Prior to installing winch, carefully inspect it for possible shipping damage.

Winches are supplied fully lubricated from the factory. Before operation check oil levels and adjust as necessary. Use the proper type of oil as recommended in the “LUBRICATION” section.

⚠ CAUTION

• Owners and users are advised to examine specific, local or other regulations, including American National Standards Institute and/or OSHA Regulations which may apply to a particular type of use of this product before installing or putting winch to use.

Mounting

Refer to Dwg. MHP0133 on page 8 and Tables 1 and 2. Care must be taken when moving, positioning or mounting the winch. In most cases, lifting lugs have been provided to assist in handling the winch. If lug locations are improper for your specific installation, great care should be taken to ensure that winch, when lifted, will be properly balanced. Determine weight of your winch by referring to the “SPECIFICATIONS” section. Lift winch 3 to 4 inches (75 to 100 mm) off ground. Verify winch is balanced and secure before continuing lift. Mount winch so the axis of drum is horizontal and that motor vent cap is not more than 15° off top vertical center. If winch is to be mounted in an inverted position, motor case must be rotated to position vent cap at top.

1. The winch mounting surface must be flat and of sufficient strength to handle rated load plus weight of winch and attached equipment. An inadequate foundation may cause distortion or twisting of winch uprights and side rails resulting in winch damage.
2. Make sure mounting surface is flat to within 0.005 inch (0.127 mm) per inch of drum length. Shim if necessary. Refer to Table 1.

Table 1–Mounting Surface Tolerance

Drum Length		Mounting Surface Minimum Flatness	
inch	mm	inch	mm
24	609.6	0.012	0.30
30	762	0.015	0.38
36	914.4	0.018	0.46
42	1066.8	0.021	0.53
55	1397	0.028	0.70

3. Mounting bolts must be 7/8 inch (22 mm) Grade 8 or better. Use self-locking nuts or nuts with lockwashers.
4. Tighten 7/8 inch (813 mm) mounting bolts evenly and torque to 600 ft lbs (515 Nm) for dry thread fasteners. If fasteners are plated, lubricated or a thread locking compound is used, torque to 460 ft lbs (624 Nm).
5. Maintain a fleet angle between sheave and winch of no more than 1-1/2°. The lead sheave must be on a center line with drum and, for every inch (25 mm) of drum length, be at least 1.6 feet (0.5 metre) from the drum. Refer to Dwg. MHP0487 on page 8.
6. Do not weld to any part of winch.

Winch Bolt Hole Mounting Dimension Drawing

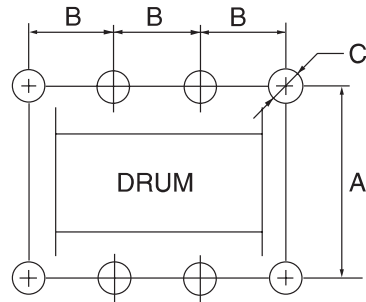

(Dwg. MHP0133)

Table 2–Winch Bolt Hole Mounting Dimensions

Dimension		Drum Length (inches)				
		24	30	36	42*	55
“A” FA7	inch	31.25			---	
	mm	794			---	
“A” FA7T	inch	34.25			37.25	
	mm	870			946	
“B” (with Drum Brake)	inch	9	10	11	10	10.25
	mm	229	254	280	254	260
“B” (without Drum Brake)	inch	8	9.5	8.5	10	10.25
	mm	203	241	216	254	260
“C”	inch	15/16				
	mm	24				

*42 inch drum length applies to FA7T (tall flange) only.

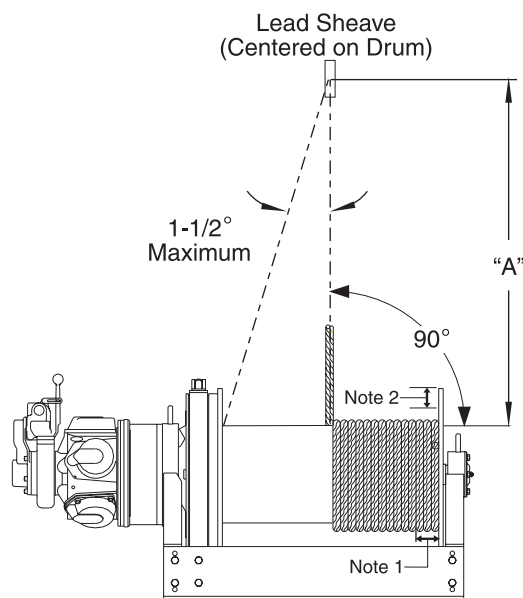

(Dwg. MHP0487)

"A" = 1.6 feet (0.5 metre) per inch of drum length:
 "A" = 38.4 feet (11.7 metres) for 24 inch drum.
 "A" = 48.0 feet (14.6 metres) for 30 inch drum.
 "A" = 57.6 feet (17.5 metres) for 36 inch drum.
 "A" = 67.2 feet (20.5 metres) for 42 inch drum.
 "A" = 88.0 feet (26.8 metres) for 55 inch drum.

Notes:

1. Maintain a minimum of 3 tight wraps of wire rope on drum at all times.
2. Ensure wire rope does not exceed top layer requirement. Refer to "SPECIFICATIONS" section.

Wire Rope

⚠ CAUTION

- Maintain at least 3 tight wraps of wire rope on drum at all times.
- Install wire rope to come off drum for overwind operation. (normal application.) Refer to Dwg. MHP0564 on page 9.

Wire Rope Take Off

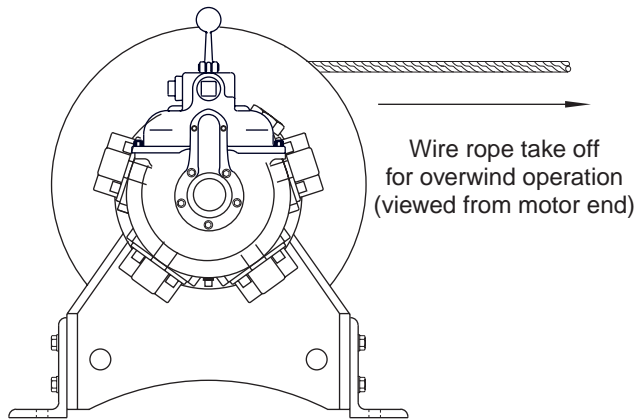

(Dwg. MHP0564)

NOTICE

- For underwound applications contact factory prior to operation.

Wire Rope Selection

Consult a reputable wire rope manufacturer or distributor for assistance in selecting appropriate type and size of wire rope and, where necessary, a protective coating. Use a wire rope which provides an adequate safety factor to handle actual working load and that meets all applicable industry, trade association, federal, state and local regulations.

When considering wire rope requirements the actual working load must include not only static or dead load but also loads resulting from acceleration, retardation and shock load. Consideration must also be given to the size of winch wire rope drum, sheaves and method of reeving. Wire rope construction should be 6 X 19 or 6 X 37 IWRC EIPS right regular lay. Refer to Table 3 on page 9 for minimum and maximum recommended wire rope sizes.

Table 3—Minimum and Maximum Wire Rope Size

Model	Minimum		Maximum	
	inch	mm	inch	mm
FA7	3/4	18	1	24
FA7T				

Installing Wire Rope

⚠ CAUTION

- To avoid disc brake damage when installing wire rope on winches, pressurize brake with a minimum of 60 psi (4.1 bar) air from an auxiliary source.

Refer to Dwg. MHP0166 on page 9.

1. Cut wire rope to length in accordance with wire rope manufacturer's instructions.
2. Feed end of wire rope into wire rope anchor hole in drum and pull through approximately one foot (305 mm) of wire rope.

Wire Rope Parts

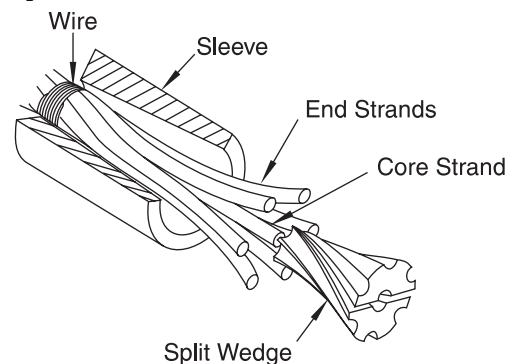

(Dwg. MHP0166)

3. Wrap wire rope with wire a distance from the end equal to wedge length plus one inch (25 mm).
4. Slide sleeve over end of wire rope so larger diameter of taper bore is nearest the end of wire rope.
5. Spread end strands of wire rope and insert split wedge until it is below the end of wire rope.
6. Pull sleeve over wire rope end until tight. Check that wire rope strands stay in slots located on split wedge.
7. Pull wire rope anchor into position in drum anchor pocket.

⚠ CAUTION

- Make sure first wrap of wire rope is tight and lays flush against drum flange.

Safe Wire Rope Handling Procedures

1. Always use gloves when handling wire rope.
2. Never use wire rope which is frayed or kinked.
3. Never use wire rope as a sling.
4. Always ensure wire rope is correctly spooled and the first layer is tight against drum.
5. Always follow wire rope manufacturers recommendation on use and maintenance of wire rope.

Wire Rope Spooling

To compensate for uneven spooling and decrease in line pull capacity as drum fills up, use as short a wire rope as practical. When rewinding apply tension to wire rope to eliminate slack. This helps achieve level winding and tight spooling.

Support wire rope spool and have wire rope come off top of spool and over top of winch drum. This will prevent damage to wire rope.

Spooling Wire Rope onto Winch Drum

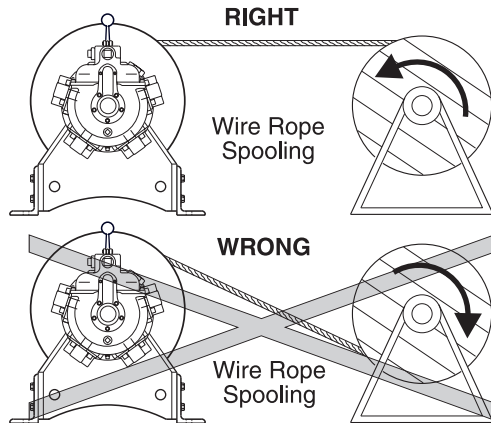

(Dwg. MHP1991)

Rigging

Make sure all wire rope blocks, tackle and fasteners have a sufficient safety margin to handle required load under all conditions. Do not allow wire rope to contact sharp edges or make sharp bends which will cause damage to wire rope, use a sheave. Refer to wire rope manufacturer's handbook for proper sizing, use and care of wire rope.

Safe Installation Procedures

1. Do not use wire rope as a ground (earth) for welding.
2. Do not attach a welding electrode to winch or wire rope.
3. Never run wire rope over a sharp edge. Use a correctly sized sheave.
4. When a lead sheave is used, it must be aligned with center of drum. The diameter of lead sheave must be at least 18 times diameter of wire rope. Refer to Dwg. MHP0487 on page 8.
5. Always maintain at least three full, tight wraps of wire rope on drum.

Air Supply

The air supply must be clean, free from moisture and lubricated to ensure optimum motor performance. Foreign particles, moisture and lack of lubrication are the primary causes of premature motor wear and breakdown. Using an air filter, lubricator and moisture separator will improve overall winch performance and reduce unscheduled down time.

Air consumption for the **FA7** and **FA7T** air motor is 750 scfm (21.5 cu. m/min) at rated operating pressure of 90 psig (6.3 bar/ 630 kPa) at winch motor inlet. If air supply varies from recommended, then winch performance will change.

Air Lines

Inside diameter of winch air supply lines must not be less than sizes shown in Table 4 on page 10. Before making final connections, all air supply lines should be purged with clean, moisture free air or nitrogen before connecting to winch inlet. Supply lines should be as short and straight as installation conditions will permit. Long transmission lines and excessive use of fittings, elbows, tees, globe valves etc. cause a reduction in pressure due to restrictions and surface friction in the lines.

Table 4—Minimum Allowable Air Supply Line Sizes

Model	inch	mm
FA7	1-1/2	38
FA7T		

Air Line Lubricator

Refer to Dwg. MHP0191 on page 10. Always use an air line lubricator with these motors. The lubricator must have an inlet and outlet at least as large as inlet on motor. Install air line lubricator as close to air inlet on motor as possible.



- Lubricator must be located no more than 10 ft. (3 m) from motor.
- Shut off air supply before filling air line lubricator.

The air line lubricator should be replenished daily and set to provide 6 to 9 drops per minute of ISO VG 32 (SAE 10W) oil. A fine mist will be exhausted from throttle control valve when air line lubricator is functioning properly.

Air Line Filter

Refer to Dwg. MHP0191 on page 10. It is recommended that an air line strainer/filter be installed as close as practical to motor air inlet port, but before lubricator, to prevent dirt from entering valve and motor. The strainer/filter should provide 20 micron filtration and include a moisture trap. Clean the strainer/filter periodically to maintain its operating efficiency.

Lubricator, Regulator, Filter Illustration

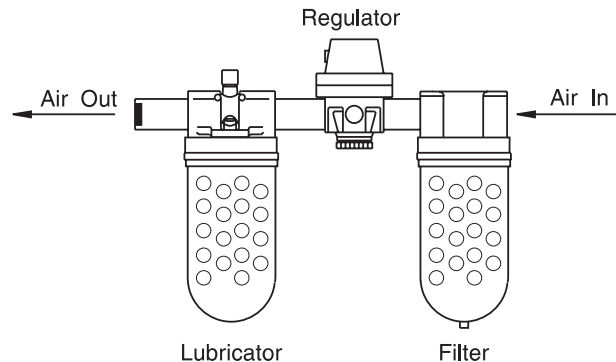

(Dwg. MHP0191)

Air Pressure Regulator

Refer to Dwg. MHP0191 on page 10.
If an air pressure regulator is used, install between lubricator and filter.

Moisture in Air Lines

Moisture that reaches the air motor through air supply lines is a primary factor in determining the length of time between service overhauls. Moisture traps can help to eliminate moisture. Other methods, such as an air receiver which collects moisture before it reaches motor or an aftercooler at compressor that cools air to condense and collect moisture prior to distribution through supply lines are also helpful.

Mufflers

Make sure mufflers are installed in winch exhaust manifold and control valve exhaust port. An additional muffler is used on winches equipped with an emergency stop and overload device. Check mufflers periodically to ensure they are functioning correctly.

Motor

For optimum performance and maximum durability of parts, provide an air supply of 90 psig at 750 scfm (6.3 bar/630 kPa at 21.5 cu. m/m) as measured at motor inlet. The air motor should be installed as near as possible to compressor or air receiver. Recommended pressures and volumes are measured at the point of entry to air motor.

Emergency Stop and Overload System (optional feature)

Refer to Dwg. MHP1492 on page 11.
The air supply line is connected to the shutoff valve which is connected to the air control valve. When Emergency Stop valve is activated, a pilot signal is sent to the shut off pilot valve which directs shutoff valve to cut off air to winch, immediately stopping all winch movement.

CAUTION

- If winch continues to move (payout load) after shutoff valve activates, brake(s) are not holding load and need to be adjusted or repaired.

The overload system also activates shutoff valve. When Delta-P valve senses a preset pressure difference between the two ports, located on rotary housing, it directs a pilot signal to shutoff pilot valve activating the shutoff valve. Refer to Dwg. MHP1491 on page 11.

Emergency Stop and Overload System Components

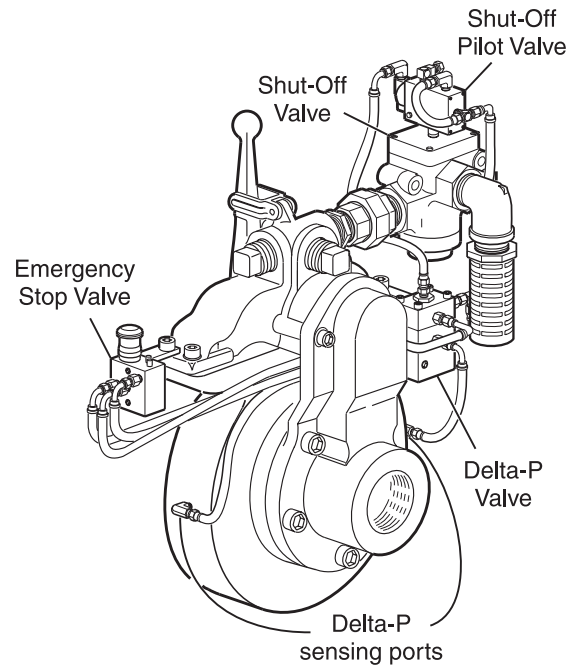

(Dwg. MHP1492)

Air Schematic—Emergency Stop and Overload System

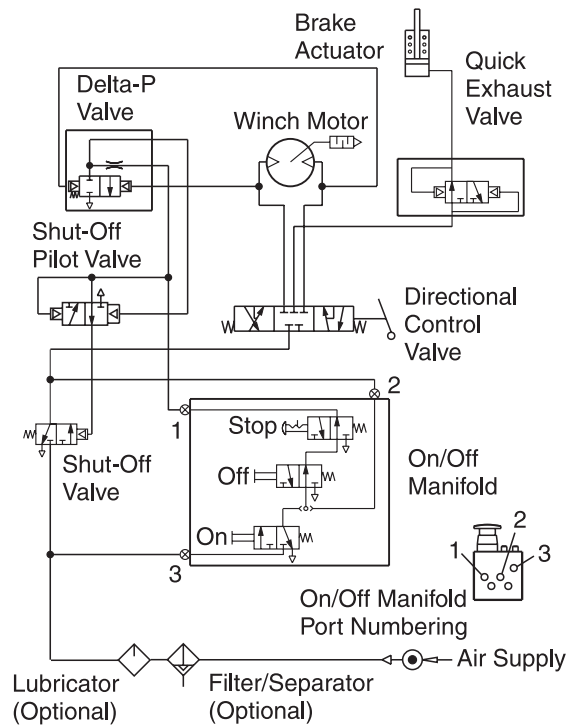

(Dwg. MHP1491)

Guideline/Podline System (optional features)

Refer to Dwg. MHP1171 on page 12.
With auxiliary valve selector in NORMAL position, winch control valve operates in normal winch operation. With the auxiliary valve selector in GUIDELINE position, winch will automatically haul-in wire rope to maintain tension.

The auxiliary valve provides a preset air pressure to air motor and disc brake. This allows the disc brake to release and winch to overhaul during guideline operations. In this position, winch will maintain a constant tension on guideline while load is being lowered.

Auxiliary valve is factory preset to maintain tension based on the weight of 5,000 ft (1524 m) of 3/4 inch (18 mm) submerged wire rope. Refer to 'Regulator Adjustment' in "MAINTENANCE" section on page 24.

Guideline/Podline Components

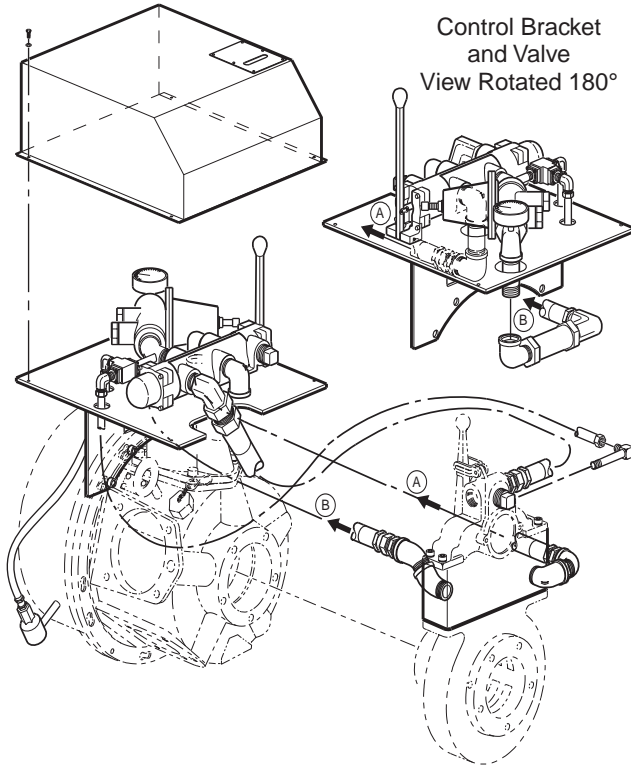

(Dwg. MHP1171)

Constant Tension (optional feature)

Refer to Dwg. MHP1865 on page 12. With auxiliary valve in the NORMAL position, winch provides normal operation. Placing valve selector in TENSIONING position allows winch to automatically operate to haul-in slack wire rope to maintain tension.

Auxiliary valve provides preset air pressure to air motor and disc brake. This allows brake to be released and winch to overhaul during TENSIONING operations. In this position, winch will maintain constant tension on wire rope.

Auxiliary valve is pre-set at zero from the factory. Specific adjustments must be made in the field. Adjustments can be modified at anytime to accommodate the load conditions. Refer to 'Regulator Adjustment' in the "MAINTENANCE" section for specific procedure.

Initial Operating Checks

Winches are tested for proper operation prior to leaving the factory. Before winch is placed into service the following initial operating checks should be performed.

1. When first running motor inject some light oil into inlet connection to provide initial lubrication.
2. When first operating winch it is recommended that motor be operated slowly in both directions for a few minutes.

For winches that have been in storage the following start-up procedures are required.

1. Give winch an inspection conforming to requirements of "Winches Not in Regular Use" in the "INSPECTION" section.
2. Pour a small amount of ISO VG 32 (SAE 10W) oil in motor inlet port.
3. Operate motor for 10 seconds in both directions to flush out any impurities.
4. The winch is now ready for normal use.

Air Schematic—Guideline and Constant Tension Winches

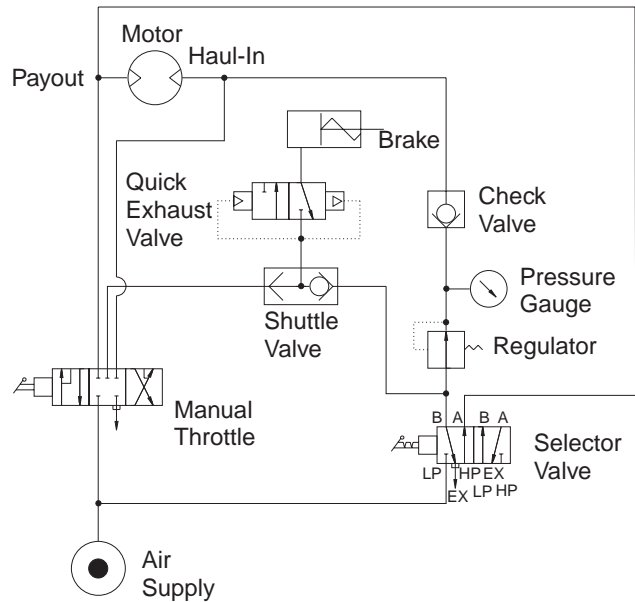

(Dwg. MHP1176)

Constant Tension Components

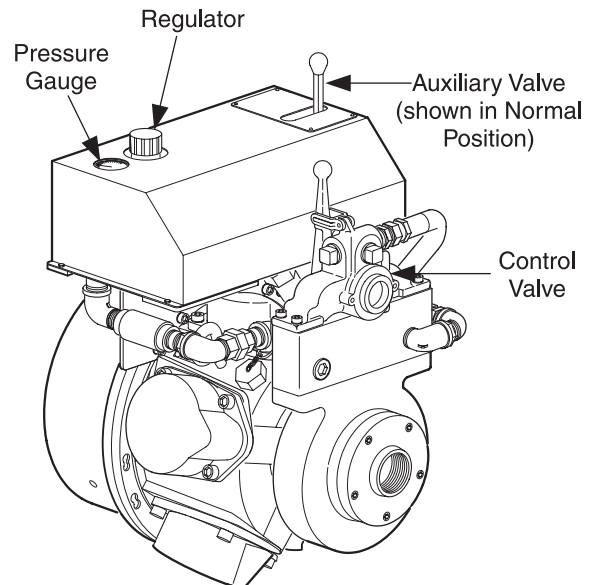

(Dwg. MHP1865)

OPERATION

The four most important aspects of winch operation are:

1. Follow all safety instructions when operating winch.
2. Allow only people trained in safety and operation of this winch to operate this equipment.
3. Subject each winch to a regular inspection and maintenance procedure.
4. Be aware of winch capacity and weight of load at all times.

CAUTION

• **To avoid damage to rigging, structure supporting rigging and winch, do not “two-block” the end of wire rope.**

* Two blocking occurs when winch wire rope is multi-reeved using two separate sheave blocks which are allowed to come into contact with each other during winch operation. When this occurs extreme forces are exerted on wire rope and sheave blocks which may result in equipment and or rigging failure.

Operators must be physically competent. Operators must have no health condition which might affect their ability to act, and they must have good hearing, vision and depth perception. The winch operator must be carefully instructed in his duties and must understand the operation of winch, including a study of the manufacturers' literature. The operator must thoroughly understand proper methods of hitching loads and must have a good attitude regarding safety. It is the operator's responsibility to refuse to operate winch under unsafe conditions.

WARNING

• **Winch is not designed or suitable for lifting, lowering or moving persons. Never lift loads over people.**

Controls

The spring loaded, motor mounted, live air manual throttle control valve is supplied as a standard feature on this winch. Optional remote throttle controls are available. Reference model code on the winch nameplate and compare it to the “SPECIFICATIONS” section, on page 5 of this manual, to determine your configuration. The throttle controls provide operator control of motor speed and direction of drum rotation.

Motor Mounted Live Air Throttle (standard feature)

Refer to Dwg. MHP1719 on page 48 and MHP0566 on page 13. The spring loaded, live air, manual control throttle valve (260) mounts to air motor.

As viewed from air motor end, move control throttle handle to the right (clockwise) to payout wire rope and to the left (counterclockwise) to haul-in wire rope. Avoid sudden movements of control valve to ensure smooth operation of winch.

When winch is not in use, engage latch to prevent inadvertent movement of control throttle.

Live Air Throttle Control Valves

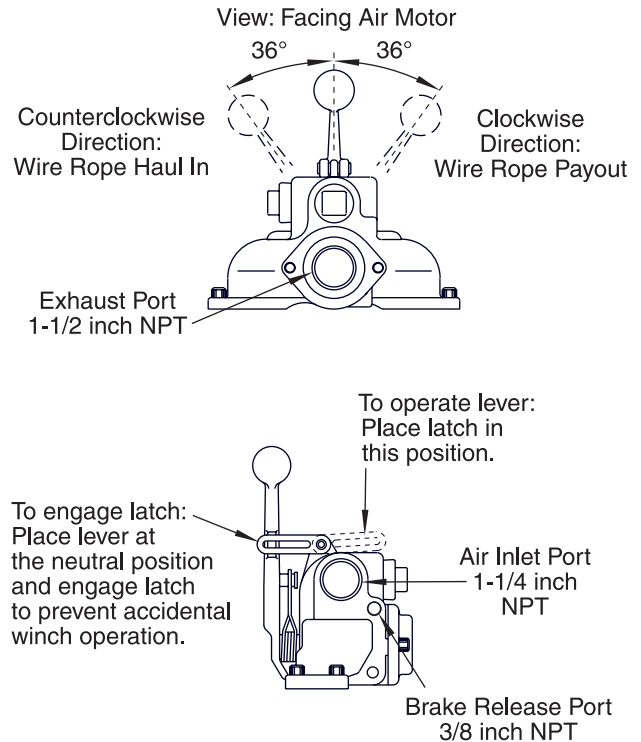

(Dwg. MHP0566)

Remote Live Air Throttle (optional feature)

Refer to Dwg. MHP0161 on page 50 and MHP0566 on page 13. Provides for remote mounting of winch control at a fixed location at up to 20 feet (6 metres) away from winch motor. Air hoses connect throttle to winch motor to provide winch operation.

Move control throttle handle to the right (clockwise) to payout wire rope and to the left (counterclockwise) to haul-in wire rope. Avoid sudden movements of control valve to ensure smooth operation of winch.

Remote Pilot Pendant Throttle (optional feature)

Refer to Dwg. MHP1311 on page 14.

Provides for remote winch control at distances of up to 50* feet (15 metres) away from winch. The pendant pilot control throttle is a two lever movable control station for winch operation. Pilot pressure from pendant pilot control throttle activates winch control valve. The winch control valve, located on winch motor, controls motor speed and direction of drum rotation. Direction of rotation is determined by the pendant lever depressed.

Pendant Hose and Operating Levers

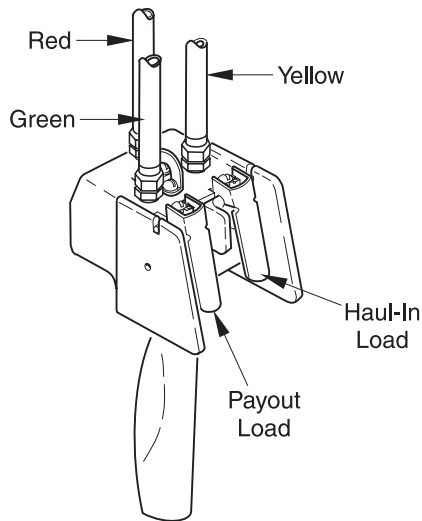

(Dwg. MHP1311)

* For distances greater than 50 feet (15 metres) contact **Ingersoll-Rand** Technical Sales for control suitability.

Depress pendant levers using smooth, even movements. To operate winch using pendant:

1. To haul-in, depress 'RIGHT' lever.
2. To payout, depress 'LEFT' lever.
3. To throttle operating speed, regulate amount pendant lever is depressed. Depress lever fully for maximum speed; partially for slower speeds.
4. To stop haul-in or payout operation, release pendant lever. Lever will spring return to off position and winch operation will stop.

Remote Pilot Lever Throttle (optional feature)

Refer to Dwg. MHP1490 on page 52, item 358. Provides for remote winch control at distances of up to 50* feet (15 metres) away from winch. The lever pilot control throttle is a fixed mount lever control station for winch operation. Pilot pressure from lever pilot control throttle activates winch control valve. The winch control valve, located on winch motor, controls motor speed and direction of drum rotation. Direction of rotation is determined by direction in which lever is shifted.

* For distances greater than 50 feet (15 metres) contact **Ingersoll-Rand** Technical Sales for control suitability.

Emergency Stop (optional feature)

Refer to Dwg. MHP1485 on page 14, MHP0754 on page 14 and MHP1488 on page 60. The emergency stop device is located to the side of the air control valve on local control models, and on pendant on remote control models. When activated, winch drum rotation will immediately cease. To activate emergency stop valve conduct the following:

1. Depress (push down) red palm valve.
2. Press emergency stop button on remote control pendant (optional feature).

Emergency Stop Operation

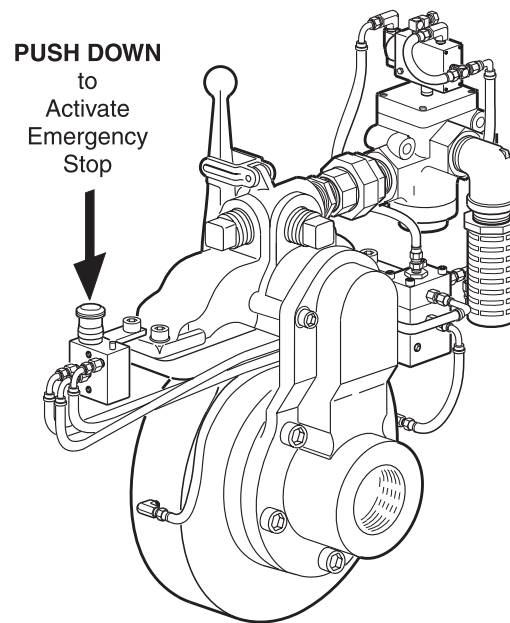

(Dwg. MHP1485)

Emergency Stop Valve Operation

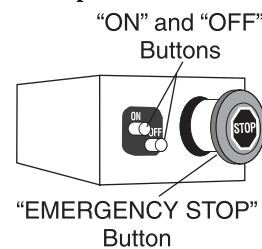

(Dwg. MHP0754)

NOTICE

• If winch overload occurs, overload device, if equipped, also stops winch by activating the emergency stop device. To operate winch after an overload, reduce load and reset emergency stop.

Reset Emergency Stop Valve:

Refer to Dwg. MHP0754 on page 14.

1. Rotate black ring, located on stop button, in clockwise direction until red stop button 'pops' up.
2. Depress emergency stop valve 'ON' button.
3. Winch is ready to resume operation.

Overload Device (optional feature)

An overload device is available on winches provided with the emergency shutoff valve option. Overload device operation is based on differential pressure between air motor inlet and exhaust. The overload device is factory preset to actuate at 150% (+/- 25%) of winch rated capacity.

When an overload condition is sensed, air is directed to the emergency shutoff valve. Emergency shutoff valve activates to secure supply air to winch, stopping winch operation. If an overload shutoff occurs, winch load must be reduced. Reset the emergency stop valve and operate winch in payout direction to lower load.

Brakes

Manual Drum Brake

Refer to Dwg. MHP1876 on page 46.

The manual drum brake may be applied by pushing down on handle (104) and released by pulling up. If handle is pushed down fully, it should lock in that position and prevent drum rotation, until released by operator. The brake must be kept properly adjusted to hold required load. Refer to "Adjustments" on page 25 in "MAINTENANCE" section for adjustment instructions.

Automatic Drum Brake (optional feature)

Refer to Dwg. MHP1876 on page 46.

The automatic drum brake is a spring applied, air released brake which utilizes an air actuated, spring loaded cylinder (110), that automatically disengages brake when motor is operated. Air pressure in cylinder overcomes spring pressure to release brake. When control valve is placed in neutral position, air in cylinder (110) is vented and spring automatically engages brake to prevent drum rotation.

The cylinder clevis (107) must be kept properly adjusted to hold required load. Refer to 'Adjustment' on page 25 in "MAINTENANCE" section.

Automatic Disc Brake (optional feature)

Refer to Dwg. MHP0152 on page 44.

The automatic disc brake is a spring applied, air released brake. Using an air actuated, spring loaded piston (10), the brake automatically disengages when motor is operated and engages when throttle is returned to neutral position.

Air pressure ported through brake housing (21) overcomes spring (9) pressure and moves piston (10) which releases brake. When control valve is placed in neutral position, air is vented, spring pressure overcomes air pressure and spring (9) pressure moves piston, engages brake and prevents drum rotation.

Drum Locking Pin (optional feature)

Refer to Dwg. MHP1237 on page 53.

The drum locking pin is mounted to winch on outboard upright, opposite motor. It should be engaged if a load is left suspended. The drum lock is operated by rotating a pin between a shallow groove (disengaged) and a deep groove (engaged).

To Engage:

1. Rotate drum (96) to align one of twelve holes in flange with locking pin (136). Pull out, straight away from outboard upright, pull rod (140) and rotate counterclockwise 90°, aligning pin (135) with deep groove in gland (405). Release pull rod and ensure locking pin engages and is seated in drum hole and gland deep groove.

⚠ WARNING

- Ensure that all braking mechanisms are engaged and all personnel are clear of winch load and rigging before disengaging locking pin.
- Extremely difficult locking pin release is an indication that load is held by locking pin and braking mechanisms are not functioning properly. Do not release locking pin until load control is established.

To Disengage:

1. Pull out, straight away from outboard upright, pull rod (140) and rotate clockwise 90°. Align pin (135) with shallow groove in gland (405) and release pull rod. Ensure locking pin (136) is clear of drum (96) flange and pin is seated in gland shallow groove.

Guideline System (optional feature)

Refer to Dwg. MHP1349 on page 15.

1. Place selector lever in NORMAL position.
2. Operate winch normally to position end of load line.
3. Connect load line to load.

Guideline Operation

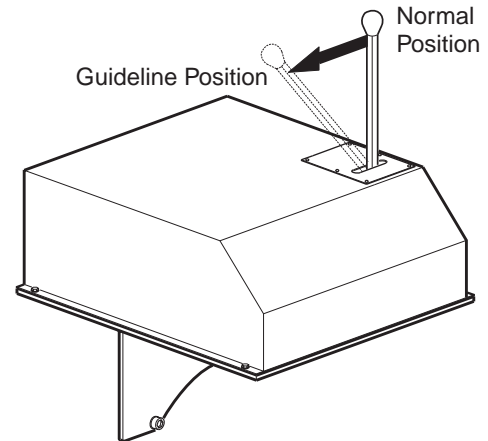

(Dwg. MHP1349)

⚠ WARNING

- Ensure slack load line is taken up by operating winch control valve with selector in NORMAL position. If selector lever is placed in GUIDELINE position the winch will immediately attempt to establish line tension causing line to 'snap' resulting in injury or damage to property.

4. Operate winch normally to remove slack from load line.
5. Shift lever to GUIDELINE position to set winch to automatically haul-in load line and maintain line tension.
6. When load is at 'work location', disengage GUIDELINE by setting selector to NORMAL and engage drum locking pin.

Contant Tension (optional feature)

1. Place auxiliary valve in NORMAL position.
2. Operate winch normally to position end of load line.
3. Connect load line to load.

⚠ WARNING

- Ensure slack load line is taken up by operating winch control valve with selector in NORMAL position. If selector lever is placed in TENSION position the winch will immediately attempt to establish line tension causing line to 'snap' resulting in injury or damage to property.

4. Operate winch normally to remove slack from load line.
5. Actuate valve to TENSION position to set winch to automatically haul-in load line and maintain line tension.

LUBRICATION

To ensure continued satisfactory operation of winch, all points requiring lubrication must be serviced with correct lubricant at proper time interval as indicated for each assembly.

The lubrication intervals recommended in this manual are based on intermittent operation of winch eight hours each day, five days per week. If winch is operated almost continuously or more than the eight hours each day, more frequent lubrication will be required. Also, lubricant types and change intervals are based on operation in an environment relatively free of dust, moisture, and corrosive fumes. Use only those lubricants recommended. Other lubricants may affect winch performance. Approval for use of other lubricants must be obtained from your **Ingersoll-Rand** distributor. Failure to observe this precaution may result in damage to winch and/or its associated components.

INTERVAL	LUBRICATION CHECKS
Start of each shift	Check flow and level of air line lubricator (approximately 6 to 9 drops per minute required at maximum motor speed).
	Check winch motor oil level.
Monthly	Lubricate components supplied by grease fittings.
	Inspect and clean or replace air line filter.
	Check reduction gear oil level.
Yearly	Drain and refill winch reduction gear oil.
	Drain and refill winch motor oil.

Note: Intervals are based on winch operation in a normal environment as described in the "INSPECTION" section. In 'Heavy' or 'Severe' operating conditions adjust lubrication intervals accordingly.

General Lubrication

Correct lubrication is one of the most important factors in maintaining efficient winch operation.

- The recommended grade of oil must be used at all times. Use of unsuitable oil may result in excessive temperature rise, loss of efficiency and possible damage to lubricated components. Refer to 'Recommended Lubricant' section.
- Drain and replace oil in motor, disc brake and reduction gear after the first 50 hours of initial winch operation. Thereafter, drain and replace oil according to operating environment (yearly in NORMAL and HEAVY; quarterly in SEVERE), or more frequently if desired.
- Always inspect removed oil for evidence of internal damage or contamination (metal shavings, dirt, water, etc.). If indications of damage are noted, investigate and correct before returning winch to service.
- After winch operation, allow oil to settle before topping off.
- Always collect lubricants in suitable containers and dispose of in an environmentally safe manner.

Recommended Lubricants

Reduction Gear Recommended Lubricant

Temperature	Type Oil
Below 32° F (0° C)	ISO VG 68 (SAE 2 EP)

Temperature	Type Oil
32° to 80° F (0° to 27° C)	ISO VG 100 (SAE 3 EP) *
Above 80° F (27° C)	ISO VG 150 (SAE 4 EP)

* Units are shipped from factory with ISO VG 100 (3 EP) lubricant. Reduction gear capacity is approximately 3.5 quarts (3.3 litres).

Air Motor Lubricant

Temperature	Type Oil
Below 32° F (0° C)	ISO VG 46 (SAE 10W)
32° to 80° F (0° to 27° C)	ISO VG 68 (SAE 20W) *
Above 80° F (27° C)	ISO VG 100 (SAE 30W)

* Units are shipped from factory with ISO VG 68 (SAE 20W) lubricant. Motor oil capacity is approximately 3 quarts (2.8 litres).

NOTICE

• Do NOT use synthetic lubricants in air motor. Synthetic lubricants will result in oil blowing by piston rings.

Disc Brake Recommended Lubricant

Temperature	Type Oil
Below 32° F (0° C)	ISO VG 68 (SAE 20W)
32° to 80° F (0° to 27° C)	ISO VG 100 (SAE 30W) *
Above 80° F (27° C)	ISO VG 150 (SAE 40W)

* Units are shipped from factory with ISO VG 100 (SAE 30W) lubricant. Motor oil capacity is approximately 5 fluid ounces (0.2 litres).

Recommended Grease

Temperature	Type Oil
-20° to 50° F (-30° to 10° C)	EP 1 multipurpose lithium based grease
30° to 120° F (-1° to 49° C)	EP 2 multipurpose lithium based grease

Component Lubrication

Motor

Refer to Dwg. MHP0565 on page 17.

The motor is splash lubricated by oil in motor housing and has no other means of lubrication. It is therefore important to use only good quality, non-detergent motor oil to ensure maximum performance and minimum downtime for repairs. Refer to the 'Recommended Lubricants' section.

Oil capacity for the K5B-546 motor is 3 quarts (2.8 litres). Add oil through filler opening until oil flows from level plug hole. Add oil slowly to prevent spilling.

The motor should be level-checked daily or at the start of each shift after any accumulated water has been drained off. When motors are operated in temperatures below freezing, wait long enough at end of shift for water to separate from oil but not long enough for it to freeze. Drain water then refill to level plug (225), located on side of motor housing (217). If desired, all oil may be drained at end of shift and motor refilled with new oil.

K5B Motor Lubrication Locations

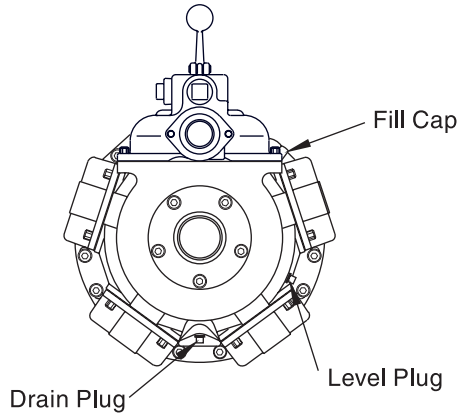

(Dwg. MHP0565)

Wire Rope

Follow wire rope manufacturer's instructions. At a minimum, observe the following guidelines.

1. Clean with a brush or steam to remove dirt, rock dust or other foreign material on surface of wire rope.

CAUTION

• Do not use an acid-based solvent. Only use cleaning fluids specified by wire rope manufacturer.

2. Apply **Ingersoll-Rand LUBRI-LINK-GREEN®** or ISO VG 100 (SAE 30W) oil as a wire rope lubricant.
3. Brush, drip or spray lubricant weekly, or more frequently, depending on severity of service.

Air Throttle

Refer to Dwg. MHP1719 on page 48 and MHP1489 on page 50. Periodically, depending on winch usage and severity of environment, lubricate lever air throttle (local and remote) with recommended grease at grease fitting (246).

Reduction Gear Assembly

Refer to Dwg. MHP0567 on page 17 and MHP0568 on page 38. It is recommended that the first oil change be done after approximately 50 hours initial operation. Always inspect removed oil for evidence of internal damage (metal shavings, dirt, water, etc.).

The reduction gear is filled to the correct levels prior to shipment from the factory. Check oil level before initial winch operation. This component is splash lubricated by oil in the housing and has no other means of lubrication. It is therefore important to use high quality Extreme Pressure (EP) rust and oxidation inhibited gear oil to ensure maximum performance and minimum down time for repair.

CAUTION

• Do not over fill. Excess oil will reduce operating efficiency and increase oil temperature.

To ensure correct performance, highest efficiency and long life, it is essential that lubricating oil be maintained at correct level. Rotate drum until fill plug is located at top dead center then add oil up to level plug hole. Oil capacity for reduction gear assembly is 3.5 quarts (3.3 litres).

Reduction Gear Lubrication Plug Locations

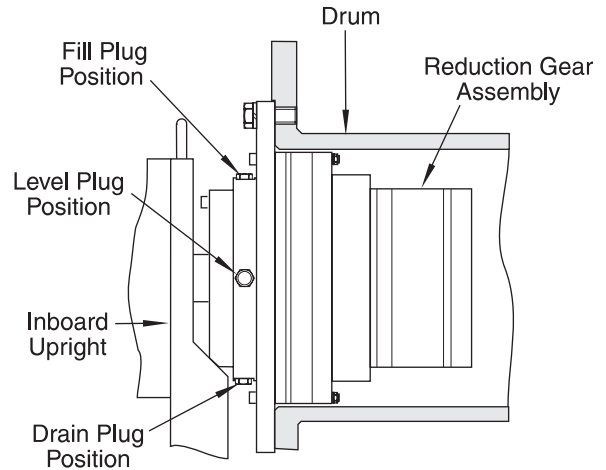

(Dwg. MHP0567)

Disc Brake

Refer to Dwg. MHP1348 on page 17.

The friction plates and drive plates are in a self contained oil bath and have no other means lubrication. After an oil change or winch overhaul remove the breather plug (22) and pour a small amount of oil [4 to 6 ounces (0.2 litres)] through breather hole in brake housing. Allow oil to fully settle between fillings.

NOTICE

• If too much oil is added excess oil will be discharged through breather plug when control valve is actuated.

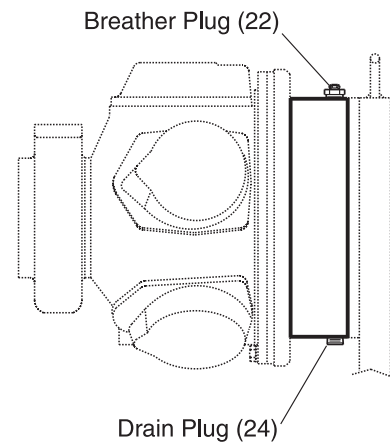

(Dwg. MHP1348)

Seals and Bearings

If winch is disassembled, clean all parts thoroughly and coat bearings and seals with clean grease. Refer to 'Recommended Lubricants' section. Use sufficient grease to provide a good protective coat. Lubricate grease fittings monthly with 2 or 3 pumps of a grease gun.

Drum Locking Pin (optional feature)

Refer to Dwg. MHP1237 on page 53.

Lubricate at least once every month, depending on environment and duty cycle, through fitting (401) located in outboard upright (184) housing with 2 or 3 pumps of a grease gun.

If drum locking pin is disassembled, clean all parts thoroughly and coat with clean grease. Refer to 'Recommended Lubricants' section. Use sufficient grease to provide a good protective coat.

Lubrication will help to prevent rust and allow easier locking pin operation.

Inspection information is based in part on American National Standards Institute Safety Codes (ASME B30.7).

⚠ WARNING

- All new or repaired equipment should be inspected and tested by personnel instructed in safety, operation and maintenance of this equipment to ensure safe operation at rated specifications before placing equipment in service.
- Never use a winch that inspection indicates is damaged.

Frequent and periodic inspections should be performed on equipment in regular service. Frequent inspections are visual examinations performed by operators or personnel trained in safety and operation of this equipment and include observations made during routine equipment operation. Periodic inspections are thorough inspections conducted by personnel trained in safety, operation and maintenance of this equipment. ASME B30.7 states inspection intervals depend upon the nature of critical components of the equipment and severity of usage. The inspection intervals recommended in this manual are based on intermittent operation of winch eight hours each day, five days per week, in an environment relatively free of dust, moisture, and corrosive fumes. If winch is operated almost continuously, or more than eight hours each day, more frequent inspections will be required.

Careful inspection on a regular basis will reveal potentially dangerous conditions while still in the early stages, allowing corrective action to be taken before the condition becomes dangerous.

Deficiencies revealed through inspection, or noted during operation, must be reported to designated personnel instructed in safety, operation and maintenance of this equipment. A determination as to whether a condition constitutes a safety hazard must be decided, and correction of noted safety hazards accomplished and documented by written report before placing equipment in service.

Records and Reports

Inspection records, listing all points requiring periodic inspection should be maintained for all load bearing equipment. Written reports, based on severity of service, should be made on condition of critical parts as a method of documenting periodic inspections. These reports should be dated, signed by the person who performed inspection, and kept on file where they are readily available for authorized review.

Wire Rope Reports

Records should be maintained as part of a long-range wire rope inspection program. Records should include the condition of wire rope removed from service. Accurate records will establish a relationship between visual observations noted during frequent inspections and actual condition of wire rope as determined by periodic inspections.

Frequent Inspection

On equipment in continuous service, frequent inspection should be made by operators at the beginning of each shift. In addition, visual inspections should be conducted during regular operation for indications of damage or evidence of malfunction (such as abnormal noises).

1. WINCH. Prior to operation, visually inspect winch housings, controls, brakes, sideplates and drum for indications of damage. Do not operate winch unless the wire rope feeds onto drum smoothly. Any discrepancies noted must be reviewed and inspected further by authorized personnel instructed in operation, safety and maintenance of this winch.
2. WIRE ROPE. Visually inspect all wire rope which can be expected to be in use during the day's operations. Inspect for wear and damage indicated by distortion of wire rope such as kinking, "birdcaging," core protrusion, main strand displacement, corrosion, broken or cut strands. If damage is evident, do not operate winch until the discrepancies have been reviewed and inspected further by personnel knowledgeable on wire rope safety and maintenance procedures.

NOTICE

• The full extent of wire rope wear cannot be determined by visual inspection. At any indication of wear inspect wire rope in accordance with instructions in "Periodic Inspection."

3. AIR SYSTEM. Visually inspect all connections, fittings, hoses and components for indication of air leaks. Repair any leaks or damage.
4. BRAKES. During winch operation test brakes. Brakes must hold load without slipping. Automatic brakes must release when winch motor throttle is operated. If brakes do not hold load, or do not release properly, brakes must be adjusted or repaired.
5. WIRE ROPE REEVING. Check reeving and ensure wire rope is properly secured to drum. Do not operate winch unless wire rope feeds onto drum smoothly.
6. LUBRICATION. Refer to "LUBRICATION" section for recommended procedures and lubricants.
7. PENDANT (optional feature). Ensure operation of pendant buttons is smooth and winch is responsive to pendant control. Pendant buttons must spring return to a position flush with pendant housing when released.
8. MANUAL THROTTLE LEVER. Ensure operation of manual throttle lever is smooth and winch is responsive to lever movement. Lever must return to neutral and lock in place when released. If winch responds slowly or controls stick, do not operate winch until all problems have been corrected.
9. LIMIT SWITCHES. If equipped, ensure limit switches engage and prevent operation at the required set point and with drum rotating in the correct direction. Ensure limit switch properly resets.
10. MOTOR. During operation check motor housing for excess heat build up. Housing should not be hot to touch. Listen for grinding or knocking noises. Ensure air supply lubricator provides 6 to 9 drops per minute of ISO VG 32 (SAE 10W) oil when winch is operated at rated capacity. Operate winch slowly in both directions to verify operation.

Periodic Inspection

Periodic inspection intervals for winch use under various conditions is listed below:

NORMAL	HEAVY	SEVERE
yearly	semiannually	quarterly

Disassembly may be required as a result of frequent inspection findings or in order to properly inspect individual components. Disassembly steps are described in "MAINTENANCE" section. Maintain written records of periodic inspections to provide an accumulative basis for continuing evaluation. Inspect all items listed in "Frequent Inspection." Also inspect the following:

1. **SIDE RAILS and UPRIGHTS.** Check for deformed, cracked or corroded main components. Replace damaged parts.
2. **FASTENERS.** Check retainer rings, split pins, capscrews, nuts, and other fasteners on winch, including mounting bolts. Replace if missing or damaged and tighten if loose.
3. **DRUM AND SHEAVES.** Check for cracks, wear or damage. Replace if necessary.
4. **WIRE ROPE.** In addition to Frequent Inspection requirements, also inspect for the following:
 - a. Build-up of dirt and corrosion. Clean with steam or a stiff wire brush to remove dirt and corrosion if necessary.
 - b. Loose or damaged end connection. Replace if loose or damaged.
 - c. Check wire rope anchor is secure in drum.
 - d. Verify wire rope diameter. Measure diameter of wire rope from crown-to-crown throughout life of wire rope. Recording of actual diameter should only be done with wire rope under equivalent loading and in same operating section as accomplished during previous inspections. If actual diameter of the wire rope has decreased more than 1/64 inch (0.4 mm) a thorough examination of wire rope should be conducted by an experienced inspector to determine the suitability of wire rope to remain in service. Refer to Dwg. MHP0056 on page 20.
5. **ALL COMPONENTS.** Inspect for wear, damage, distortion, deformation and cleanliness. If external evidence indicates damage, disassemble as required to conduct a detailed inspection. Inspect gears, shafts, bearings, sheaves, springs and covers. Replace worn or damaged parts. Clean, lubricate and reassemble.

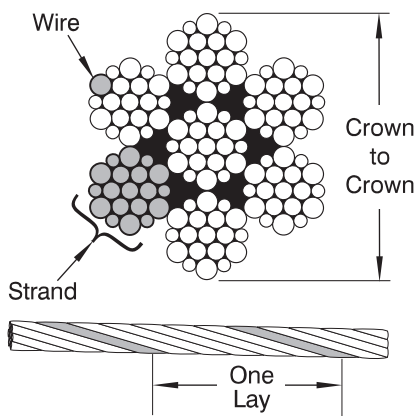

(Dwg. MHP0056)

6. **BRAKES.** Individually test brakes installed to ensure proper operation. Brakes must hold a **125% rated load** at mid drum without slipping. If indicated by poor operation or visual damage, disassemble and repair brake(s). Check all brake surfaces for wear, deformation or foreign deposits. If brake lining thickness is less than minimum as described in "MAINTENANCE" section replace brakes. Clean and replace components as necessary. Adjustments cannot be made to disc brake. The disc brake must be repaired as described in "MAINTENANCE" section.
7. **FOUNDATION OR SUPPORTING STRUCTURE.** Check for distortion, wear and continued ability to support winch and rated load. Ensure winch is firmly mounted and that fasteners are in good condition and tight.
8. **LABELS AND TAGS.** Check for presence and legibility of labels. Replace if damaged or missing.
9. **DRUM GUARD (optional feature).** Verify fasteners are tight and in good condition. Ensure guard is in good condition.
10. **EMERGENCY STOP VALVE (optional feature).** During winch operation verify emergency shut-off valve operation. Valve must stop winch operation quickly. Valve must reset properly. Refer to 'Emergency Stop Valve' in the "OPERATION" section for procedures.
11. **OVERLOAD DEVICE (optional feature).** Ensure overload device is properly set to stop winch when the load exceeds 150% (+/- 25%) of winch rated capacity. If winch does not shut down, contact your distributor or factory for repair information.
12. **LIMIT SWITCHES (optional feature).** Operate winch in both directions to activate limit switches. Limit switches should engage (stop winch operation) at established settings (+/- 2 feet [+/- 0.6 metre]). Reset switch by operating winch in opposite direction. Refer to 'Limit Switch Adjustment' on page 25 in "MAINTENANCE" section.

Winches Not in Regular Use

1. Equipment which has been idle for a period of one month or more, but less than six months, shall be given an inspection conforming to requirements of "Frequent Inspection" before being placed in service.
2. Equipment which has been idle for a period of over six months shall be given a complete inspection conforming with requirements of "Periodic Inspection" before being placed in service.
3. Standby equipment shall be inspected at least semi-annually in accordance with requirements of "Frequent Inspection". In abnormal operating conditions, equipment should be inspected at shorter intervals.

INSPECTION AND MAINTENANCE REPORT

Ingersoll-Rand Force 5 Series FA7 and FA7T Air Winches

Model Number:	Date:
Serial Number:	Inspected by:

Reason for Inspection: (Check Applicable Box)

1. Scheduled Periodic Inspection (____ Quarterly ____ Semiannually ____ Yearly)	Operating Environment: Normal ____ Heavy ____ Severe ____
2. Discrepancy(s) noted during Frequent Inspection	
3. Discrepancy(s) noted during maintenance	
4. Other: _____	

Refer to the Parts, Operation and Maintenance Manual "INSPECTION" section for general inspection criteria. Also, refer to appropriate National Standards and Codes of practice. If in doubt about an existing condition, contact the nearest **Ingersoll-Rand** Distributor or the factory for technical assistance.

COMPONENT	CONDITION		CORRECTIVE		NOTES
	Pass	Fail	Repair	Replace	
Uprights and Side Frames					
Drum Band Brake (125% Load Test)					
Disc Brake (125% Load Test)					
Drum Band Brake (Visual Inspection)					
Disc Brake (Visual Inspection)					
Motor					
Limit Switches					
Controls					
Air System					
Fasteners					
Reduction Gears					
Labels and Tags			---		
Shafts					
Wire Rope Anchor			---		
Emergency Stop Valve			---		
Overload Device			---		
Wire Rope			---		
Other Components (list in NOTES section)					

TESTING	PASS	FAIL	NOTES
Operational (No Load)			
Operational (10% Load)			
Operational (Maximum Test Load*)			

* Maximum test load is 125% of rated line pull. Testing to more than 125% of rated load may be required to comply with standards and regulations set forth in areas outside the USA.

This form may be copied and used as an inspection/maintenance record.

TROUBLESHOOTING

This section provides basic troubleshooting information. Determination of specific causes to problems are best identified by thorough inspections performed by personnel instructed in safety, operation and maintenance of this equipment. The chart below provides a brief guide to common winch symptoms, probable causes and remedies.

SYMPTOM	CAUSE	REMEDY
Winch will not operate.	No air supply to winch.	Check air supply line connections and hoses.
	Winch is overloaded.	Reduce load to within rated capacity.
	Disc brake does not release.	Pressurize disc brake release port and check for leakage. Replace brake piston seals if leakage is found. Ensure air pressure at inlet to disc brake is at least 50 psig (3.4 bar/340 kPa).
	Shipping plugs may still be in place.	Remove shipping plugs in valve and motor exhaust ports.
	Drum brake does not release.	Disengage manual drum brake, or refer to 'Automatic Drum Brake Adjustment' on page 25.
Load continues to move when winch is stopped.	Drum brake is slipping.	Check drum brake adjustment on page 25 and brake band lining wear.
	Winch is overloaded.	Reduce load to within rated capacity.
	Winch motor controls sticking.	Check pendant/throttle levers spring return to normal (neutral) positions when released.
Winch does not lift load or does not lift rated capacity.	Motor may be damaged.	Remove and disassemble motor as described in the "MAINTENANCE" section on page 24. Examine all parts and replace any that are worn or damaged.
	Insufficient air supply.	Verify air supply pressure and volume at winch inlet meets requirements listed in the "SPECIFICATIONS" section on page 5. Clean air line filter.
Throttle or pendant lever moves but winch does not operate.	Motor may be damaged.	Disassemble and clean motor and replace any broken or damaged parts.
	Insufficient air supply.	Ensure air pressure at winch inlet is at least 90 psig (6.3 bar/630 kPa) at rated volume. Clean air line filter.
	Air leak.	Check hose and fitting connections. Inspect hose(s) for breaks. Tighten fittings and repair or replace hoses as necessary.
Motor runs hot or makes excessive noise during operation.	Low oil level.	Check oil level in motor. Add oil as required to obtain proper level.
	Improper lubrication.	Replace oil with type recommended in "LUBRICATION" section on page 16. Set lubricator to provide 6 to 9 drops of oil per minute at maximum winch operating capacity.
	Water in oil.	Drain and refill with recommended oil. Operate winch with no load slowly, in both directions. If noise still exists or motor overheats disassemble and repair motor.
	Damaged or broken piston or connecting rod.	Disassemble and repair motor.
Winch runs slow.	Improper hose or fitting sizes.	Check fittings, connections and hoses for correct size and length. Replace parts that may cause restricted air flow. Inspect air line filter.
	Motor may be damaged.	Remove and disassemble motor as described in the "MAINTENANCE" section on page 24. Inspect all parts and replace all worn or damaged parts.
	Brake(s) not releasing.	Refer to brakes in "MAINTENANCE" section on page 24.
Air lines freeze.	Water in air supply.	Install or drain air system moisture traps, moisture collecting air receivers and compressor aftercoolers. After corrective action has been taken, disconnect lines at winch inlet and purge with clean, dry air or nitrogen.
Throttle lever hard to actuate, or lever does not spring return to neutral.	Valve body sticking in bushing.	Lubricate valve through grease fitting with recommended lubricant. Refer to 'Air Throttle' on page 17 in "LUBRICATION" section.

Automatic Drum Brake:

Brake cylinder will not release.	Drum brake out of adjustment.	Adjust drum brake to maintain correct cylinder stroke.
	Leaking cylinder seals.	If air is noticed escaping from cylinder breather when attempting to release brake, replace or repair cylinder.
	Dirty filter in air supply.	Clean or replace filter.
	Faulty dump valve.	Check dump valve exhaust port. Air should exhaust when control valve handle is in neutral. If no air escapes, replace dump valve.

SYMPTOM	CAUSE	REMEDY
Automatic Disc Brake:		
Brake fails to release.	Low air supply pressure.	Ensure air pressure at inlet to disc brake is at least 50 psig (3.4 bar/340 kPa).
	Leaking piston seals.	Inspect brake breather. If air escapes from brake breather when attempting to release brake, replace brake seals.
	No release pressure at brake port.	Check for proper operation of winch controls.
	Sticking brake piston.	Apply 50 psig (3.4 bar/340 kPa) to brake release port and check for brake disc movement. (Brake discs can be viewed through brake breather hole.) If brake discs do not move, disassemble and inspect disc brake as described in "MAINTENANCE" section.

MAINTENANCE

⚠ WARNING

- Never perform maintenance on winch while it is supporting a load.
- Before performing maintenance, tag controls:
WARNING - DO NOT OPERATE - EQUIPMENT BEING REPAIRED.
- Only allow service personnel trained in safety and service on this winch to perform maintenance.
- After performing any maintenance on winch, test winch to 125% of its rated capacity before returning to service. Testing to more than 125% of rated capacity may be required to comply with standards outside the USA.
- Shut off air system and depressurize air lines before performing any maintenance.

Maintenance Intervals

The Maintenance Interval chart is based on intermittent operation of winch eight hours each day, five days per week. If winch operation exceeds eight hours per day, or use is under HEAVY or SEVERE conditions, more frequent maintenance should be performed. Refer to 'Periodic Inspection' on page 20 in "INSPECTION" section for interval guidance.

INTERVAL	MAINTENANCE CHECK
Start of each shift (Operator or Maintenance Personnel)	Make a thorough visual inspection of winch for damage. Do not operate winch if damaged.
	Operate winch at low RPM in both directions. Winch must operate smoothly without sticking, binding or abnormal noises. Check operation of brake(s)
3 Months (Maintenance Personnel)	Inspect drum brake friction linings. Clean or replace parts as required. Adjust drum brake as necessary.
Yearly (Maintenance Personnel)	Inspect winch gearing, shafts and bearings for wear and damage. Repair or replace as necessary.
	Check all supporting members, including foundation, fasteners, nuts, sheaves and rigging, etc. for indications of damage or wear. Repair or replace as required.

Thermoplastic Coating

Thermoplastic coating is an extremely tough and durable coating designed to take the toughest treatment without chipping or peeling. Special steps must be taken to protect the coating when parts are removed, replaced and if excessive environmental or operational conditions have damaged the coating.

Cleaning Parts

The area to be coated must be clean and free from loose coating. Remove any surface corrosion. To paint thermoplastic coated parts, the parts must be sand blasted in order to 'rough up' the surface for proper paint adhesion. Sand blasting will not remove thermoplastic coating (abrasive material will bounce off).

Loose coating can be removed by cutting with a sharp cutting tool (chisel, putty knife or knife).

Heat Source

⚠ WARNING

- When using an open flame be aware of the materials around the work area. Some solvents, lubricants and materials are extremely flammable.
- Drain all components of lubricants, water or any other fluids. Remove, or open all vents and drains. Components will be hot and may discharge hot fluids or gases. Allow sufficient time for components to cool, or cool off components, prior to handling. Gaskets, seals, 'O' rings, and any components that may be damaged should be removed prior to applying coating.

Thermoplastic coating is heat applied. The surface of the component to which the thermoplastic coating is being applied must be maintained at a temperature of at least 230° F (110° C), but not over 450° F (232° C). Optimum temperature is 300° F (149° C) for best results. A small propane torch (**Ingersoll-Rand** Part No. 71308886) or heat gun (**Ingersoll-Rand** Part No. 71308894) can be used.

NOTICE

- When using a heat source always keep it moving. Small circles work best. Failure to do so will result in a scorched area at the repair.

The choice of heat gun or propane torch depends on the size of the area to be coated and the amount of time available to accomplish the task. The propane torch heats the surface faster, but is hard to control and can scorch the coating. The heat gun is slower, easier to control and generally results in a better looking finish.

Repairing Surfaces

For minor repairs to the thermoplastic coating conduct the following:

1. If the under laying surface is not corroded and the scratch is less than 1/16 inch (1.6 mm) wide the surrounding thermoplastic coating can be heated until the material flows together. For clean surfaces with damage greater than 1/16 inch (1.6 mm) heat the area and then apply thermoplastic coating powder (**Ingersoll-Rand** Part No. 71308902 [2 oz. (56.7 g)]) to fill the area. Continue heating until coating liquefies and flows together with the existing coating.

- Corrosion in damaged area must be removed. Sandblast or wire brush the area to remove corrosion. If corrosion exists, ensure the corrosion has not penetrated below the surface of existing thermoplastic coating. This can usually be easily determined by checking to see if the coating is loose around the corroded area. Cut away coating as necessary to expose corrosion for removal. If the damaged area is less than 1/16 inch (1.6 mm) wide the surrounding thermoplastic coating can be heated until the material flows together. For surfaces with damage greater than 1/16 inch (1.6 mm) heat the area and then apply thermoplastic coating powder, **Ingersoll-Rand** Part No. 71308902 [2 oz. (56.7 g)], to fill the area. Continue heating until coating liquefies and flows together with the existing coating.
- Allow the repaired area to cool. Quenching with water is acceptable. Inspect the repair. Rough spots, minor scorching and excess coating deposits can be wet sanded to remove the imperfections. To return the gloss finish, reheat the surface carefully.

For large bare surfaces or new parts:

Coating these components can be done more economically and with better end results by using an electrostatic powder application process or flamespray process. Contact **Ingersoll-Rand** Technical Assistance for more information.

For specific disassembly and assembly information refer to ‘Assembly’ or ‘Disassembly’ in the “MAINTENANCE” section.

Adjustments

Disc Brake Adjustment

Refer to Dwg. MHP0152 on page 44.
Disc brake adjustment is not required. If disc brake does not hold rated load disassemble and repair.
If brake assembly is removed or disassembled ensure breather (23) is installed and located at top of brake housing during reassembly.

Manual Drum Brake Adjustment

- Refer to Dwg. MHP1876 on page 46.
- Release wire rope tension on drum.
 - Raise handle (104) to free brake bands (128).
 - Remove cotter pin (102) and pin (101).
 - Rotate link stud (103) clockwise to increase brake torque.
 - Install pin (101) and check adjustment.
 - Brake should be adjusted until brake lever over center position can be attained with 50 to 100 lb. (23 to 45 kg) force on handle (104).
 - Install cotter pin (102) when adjustment is completed. Bend ends of cotter pin over.



• When any part of brake lining measures 0.062 inch (2 mm) or less, brake bands (128) or linings must be replaced.

Automatic Drum Brake Adjustment

- Refer to Dwg. MHP1876 on page 46.
- Remove cotter pin (102) and washer (129) at adjustment clevis (107).

- Apply air to brake cylinder (110) and remove pin (106) and second washer (129) to disconnect clevis from brake lever (105).
- Turn adjustment clevis (107) clockwise to increase cylinder rod extension. Turn clevis counterclockwise to decrease cylinder rod extension.
- Assemble clevis (107) to brake lever (105) with washer (129) and pin (106). Release air to brake cylinder (110).
- Brake should hold rated load (refer to “INSPECTION” section on page 19) when cylinder (110) is retracted. Brake band should not drag on drum when cylinder is extended.
- Install cotter pin (102) and second washer (129). Bend ends of cotter pin to secure clevis to brake lever when adjustment is complete.
- With brake “On”, adjust screw (127) to just touch arm (124).

Pilot Air Control Valve Adjustment (optional feature)

Refer to Dwg. MHP0141 on page 49.
If winch operating speeds differ from performance specifications pilot air control valve may require adjustment. Loosen nut (271) and adjust adjusting screw (270), located in valve end cap (268), until drum speed for no-load haul-in equals drum speed for full load payout. Adjust screw ‘OUT’ (counterclockwise turn) to increase speed; adjust screw ‘IN’ (clockwise turn) to decrease speed. It is suggested that a chalk mark be placed on drum flange so that drum rpm can be accurately counted.

Overload Valve Adjustment

- Refer to Dwg. MHP1295 on page 26.
- Adjust overload valve by turning setscrew located at bottom of Delta-P valve.
 - Rotating setscrew **clockwise** will **increase** pressure required to activate overload valve.



• This adjustment can cause overload device to NOT activate before winch’s safety limit is exceeded. This procedure should only be done by personnel trained in testing and servicing this winch.

- Rotating setscrew **counterclockwise** will **decrease** pressure required to activate overload valve.

Checking Overload Valve Setting:

- Attach load line to a load that is calibrated to the maximum load for which winch is rated. Move control lever to haul-in position. If winch does not lift load, adjust the setscrew as described above.

Setting the Overload:

- Attach load line to a load that is calibrated to 150% of winch rated capacity. Shift control lever to haul-in position.
 - If overload valve is activated, reset emergency stop valve. Winch is ready for normal operation
 - If winch lifts load, lower load. Turn adjustment screw counterclockwise in ¼ turn increments until overload valve is activated when control lever is shifted to haul-in position. After each ¼ turn, retest winch.

Overload Valve Adjustment

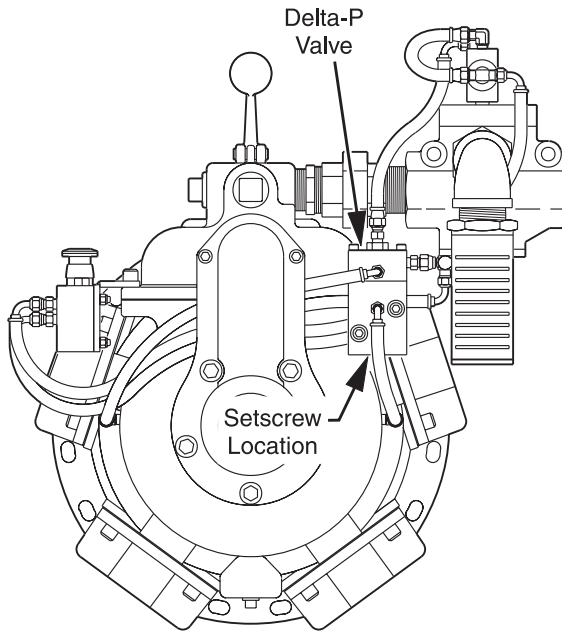

(Dwg. MHP1295)

Guideline Winch Control Adjustments

Regulator Adjustment

Refer to Dwg. MHP1329 on page 56.

The regulator (721) on bracket (742) is factory preset at approximately 50 psig (3.5 bar/349 kPa) to maintain tension of 4500 lbs (2045 kg) on load line. To change this preset for specific load applications, regulator pressure may be adjusted to increase or decrease tension setting.

⚠ WARNING

- When adjusting regulator, ensure winch control lever is locked in neutral position and guideline selector lever is in the NORMAL position. Refer to Dwg. MHP1349 on page 15.
- Winch supply air is NOT turned off during regulator adjustments. To prevent accidental winch operation, allow only a single person, trained in operation, safety and maintenance of this product, to conduct regulator adjustments.

Regulator Adjustment Procedure

Refer to Dwg. MHP1329 on page 56.

1. Remove valve handle ball (722).
2. Remove cover (706).
3. Loosen jam nut on regulator (721). Refer to Dwg. MHP1175 on page 26.

⚠ WARNING

- Ensure slack load line is taken up by operating winch control valve with selector in NORMAL position. If selector lever is placed in GUIDELINE position the winch will immediately attempt to establish line tension causing line to 'snap' resulting in injury or damage to property.

Regulator (721) Adjustment

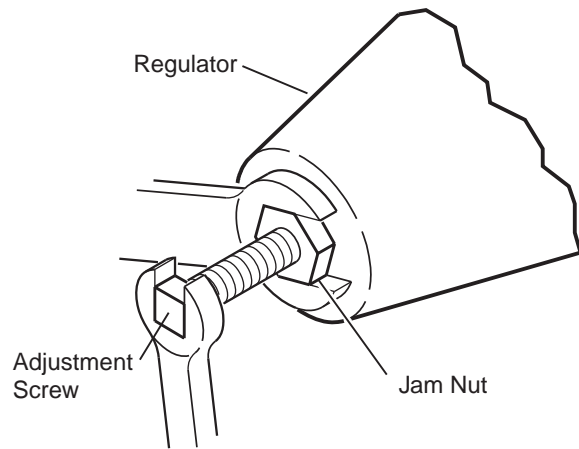

(Dwg. MHP1175)

4. Place selector lever into GUIDELINE position.
5. Observing pressure gauge (707), rotate regulator adjustment screw. Refer to Dwg. MHP1175 on page 26.

NOTICE

- Clockwise turns increase regulator pressure resulting in increased load line tension. Counterclockwise turns decrease regulator pressure resulting in decreased load line tension.

6. Increase or decrease pressure setting in 5 psig (0.35bar/34 kPa) increments. Allow winch to adjust to setting before proceeding. Repeat adjustment until required tension is established.

⚠ CAUTION

- Continuous overhauling at regulator pressures equal to or greater than 70 psig (4.8 bar/483 kPa) may cause winch damage.

Constant Tension

Refer to Dwg. MHP1865 on page 12.

The regulator is preset at 0 psig (0 bar/0 kPa), therefore requires adjustment when winch is installed. To adjust for specific load applications, regulator pressure may be adjusted to increase or decrease tension setting.

Regulator gauge and regulator are accessible through cover.

⚠ WARNING

- When adjusting regulator, ensure winch control lever is locked in neutral position and tension selector lever is in the NORMAL position.
- Winch supply air is NOT turned off during regulator adjustments. To prevent accidental winch operation, allow only a single person, trained in operation, safety and maintenance of this product, to conduct regulator adjustments.

Regulator Adjustment Procedure

Refer to Dwg. MHP1865 on page 12.

1. Attach test load of desired weight to load line, or connect load line to scale.

⚠ WARNING

• **Ensure load line is connected to load and excessive slack is taken up before activating auxiliary valve. When activated, auxiliary valve will automatically engage and winch will operate at full speed to set tension on load line.**

2. With winch control valve remove all slack from load line.

Setting with test load:

3. Actuate auxiliary valve to TENSIONING position. Winch should operate, causing load line to become taut. To increase tension, turn regulator knob clockwise until load begins to rise. Turn regulator knob counterclockwise a minimum of $\frac{1}{4}$ turn, or until load is balanced (does not raise or lower). Note pressure indicated on gauge for future setting reference.

Setting with scale:

4. Actuate auxiliary valve to TENSIONING position. Winch should operate, causing load line to become taut. To increase tension, turn regulator knob clockwise until scale indicates desired tension. Note pressure indicated on gauge for future setting reference.

Limit Switch Adjustment

⚠ CAUTION

• **Maintain at least 3 tight wraps of wire rope on the drum at all times. Ensure wire rope full drum top layer is a minimum of $\frac{1}{2}$ inch (13 mm) below drum flange edge. Refer to Dwg. MHP0487 on page 8.**

Adjustments described are as viewed when facing limit switch assembly from wire rope takeoff side of winch.

Limit Switch Adjustment

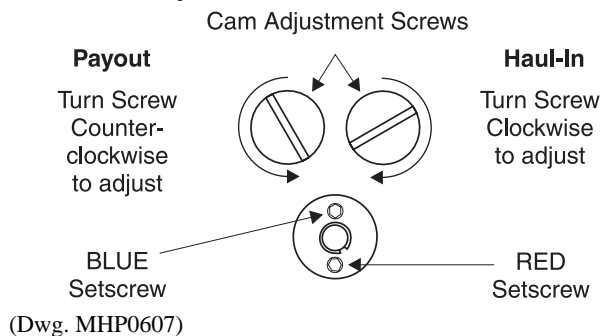

To set winch maximum wire rope payout limit switch:

Refer to Dwg. MHP1866 on page 64.

1. Remove cover plate (677) from top of limit switch (666).
2. Loosen blue setscrew in center of limit switch, below cover plate.
3. Position winch wire rope at desired payout position.
4. Rotate left cam adjustment screw **counterclockwise** until it fully activates cutoff valve, causing system air to vent. $2\frac{3}{4}$ turns of the cam adjustment screw are required for each full cam revolution.
5. Hold cam adjustment screw in position (venting air) and tighten blue setscrew to lock cam in place.

6. If required, adjust haul-in limit switch. Test winch setpoints by operating winch through three complete cycles to ensure constant limit switch operation within ± 2 feet (0.6 metre) of setpoints.
7. Install cover plate when final adjustments are complete.

To set winch maximum wire rope haul-in limit switch:

1. Remove cover plate (677) from top of limit switch (666).
2. Loosen red setscrew in center of limit switch, below cover cover.
3. Position winch wire rope at desired haul-in position.
4. Rotate right cam adjustment screw clockwise until it fully activates cutoff valve, causing system air to vent. $2\frac{3}{4}$ turns of cam adjustment screw are required for each full cam revolution.
5. Hold cam adjustment screw in position (venting air) and tighten red setscrew.
6. If required, adjust payout limit switch. Test winch setpoints by operating winch through three complete cycles to ensure constant limit switch operation within ± 2 feet (0.6 metre) of setpoints.
7. Install cover cover when final adjustments are complete.

Disassembly

General Disassembly Instructions

The following instructions provide necessary information to disassemble, inspect, repair, and assemble winch. Parts drawings are provided in parts section. If a winch is being completely disassembled for any reason, follow the order of topics as they are presented. It is recommended that all maintenance work on winch be performed in a clean dust free work area.

In the process of disassembling winch, observe the following:

1. Never disassemble winch any further than is necessary to accomplish needed repair. A good part can be damaged during the course of disassembly.
2. Never use excessive force when removing parts. Tapping gently around perimeter of a cover or housing with a soft hammer, for example, is sufficient to break the seal.
3. Do not heat a part with a flame to free it for removal, unless part being heated is already worn or damaged beyond repair and no additional damage will occur to other parts.

In general, winch is designed to permit easy disassembly and assembly. The use of heat or excessive force should not be required.

4. Keep work area as clean as practical, to prevent dirt and other foreign matter from getting into bearings or other moving parts.
5. All seals and 'O' rings should be discarded once they have been removed. New seals and 'O' rings should be used when assembling winch.
6. When grasping a part in a vise, always use leather-covered or copper-covered vise jaws to protect the surface of part and help prevent distortion. This is particularly true of threaded members, machined surfaces and housings.
7. Do not remove any part which is a press fit in or on a subassembly unless removal of that part is necessary for repairs or replacement.
8. When removing ball bearings from shafts, it is best to use a bearing puller. When removing bearings from housings, drive out bearing with a sleeve slightly smaller than outside diameter of bearing. The end of sleeve or pipe which contacts bearing must be square. Protect bearings from dirt by keeping them wrapped in clean cloths.

Thermoplastic Coated Parts Disassembly

Thermoplastic coating on capscrew heads, nuts, housings and other components can be removed as follows:

CAUTION

• **Separate parts using proper tools. Ensure machined surfaces are not damaged during disassembly.**

1. Fasteners:
 - a. Push tool into or over fastener, forcing coating off of the fastener.
 - b. If coating is too thick, then heat the fastener to soften coating. Socket or wrench will push softened coating off, allowing removal of part.
 - c. For socket head capscrews, setscrews, etc., heat the component until coating is softened. Use a small screwdriver or similar tool to remove coating to allow access for wrench.
2. For housings, plates and other coated mating components use a sharp knife or similar tool to cut through coating around mating area of components.

Winch Disassembly

Refer to Dwg. MHP1714 on page 42.

1. Remove wire rope from drum.
2. Operate winch to position reduction gear drain plug at its lowest position.
3. Relieve pressure in air lines by operating winch control several times after air supply has been turned off.

WARNING

• **Shut off, bleed down and disconnect air supply line before performing any disassembly procedures.**

4. Disconnect and tag air lines.
5. Remove winch from its mounting and take to a suitable work area before beginning disassembly.
6. Remove lower case drain plug (225) on K5B motor housing (217) and allow oil to drain into a suitable container. Loosen fill cap (210) to vent motor housing.
7. Drain oil from reduction gear assembly by removing one plug (56) when positioned at its lowest point, and one plug (56) from its highest point to vent. Refer to Dwg. MHP0567 on page 17 in "LUBRICATION" section. If winch is equipped with a drum band brake elevate winch outboard end (opposite from motor end) to prevent draining oil from contaminating brake band lining.
8. For winches with a disc brake remove pipe plug (24) in brake housing (21) to drain brake oil.
9. Remove drum band brake, drum guard and any other externally mounted winch attachments.

WARNING

• **The K5B air motor weighs approximately 260 lb. (118 kg). Adequately support air motor before removing motor mounting capscrews.**

10. Remove capscrews (4) and lockwashers (3) securing motor assembly to motor adapter (6). Using a hoist to support motor, pull motor straight away from winch. Reference the 'K5B Motor Disassembly' section on page 30 if motor disassembly is required.

Instructions 11 through 17 apply only to winches with a disc brake.

11. Alternately and evenly loosen eight capscrews (1) until brake spring compression is relaxed. Remove capscrews and motor adapter (6).
12. Remove brake housing (21). If brake housing sticks, tap it with a soft faced hammer until parts separate.

Note position of all brake parts for reassembly.

13. Remove three friction plates (16) and two drive plates (17).
14. Remove springs (9) from brake piston (10).
15. Remove brake piston (10) from brake housing (21). Tap lightly with a plastic mallet to separate parts if necessary.
16. Remove seals (11) and (12) from brake piston (10).
17. Loosen capscrew in collar (18) and slide collar from shaft (35) with splined hub (19). Remove spacer (34) from shaft (35).
18. Remove retainer ring (36) from bore of drum shaft (41).
19. Pull shaft and bearing assembly from drum shaft (41).

NOTICE

• **Remove drum brake if equipped. Refer to 'Manual or Automatic Drum Brake' disassembly section on page 29 for specific instructions.**

20. Support drum (96) and remove capscrews (39) from drum shaft (41). Pry drum shaft (41) from inboard upright (42).
21. Remove capscrews (116) and lockwashers (117) securing side rails (98) and (99) to inboard upright (42). Drive out dowel pins (51).
22. Remove inboard upright (42).
23. Remove end cover (193), capscrews (196) and lockwashers (154) from outboard upright (184). Remove spacer (189).
24. Remove capscrews (192) and bearing retainer (191) from drum (96).
25. Remove drum and reduction gear assembly.
26. Remove remaining capscrews (116) and lockwashers (117) attaching side rails (98) and (99) to outboard upright (184). Drive out dowel pins (51).
27. Remove bearing (188) and seal (187) from outboard upright (184).
28. Remove capscrews (45) and lockwashers (46) securing drum adapter (52) to drum (96).
29. Install two ½ inch - 13 NC x 3 inch long capscrews into threaded holes in outer bolt pattern ring of drum adapter (52). Use these capscrews to break seal. Remove reduction gear/gear carrier assembly from drum (96).
30. Remove capscrews (50), nuts (83) and two dowel pins (51) to separate drum adapter (52) from reduction gear assembly.

To disassemble reduction gear refer to **Reduction Gear Disassembly** section.

Manual or Automatic Drum Brake Disassembly

Refer to Dwg. MHP1876 on page 46.

Actuator Disassembly:

1. Automatic Brake
 - a. Disconnect and remove hose, fittings and dump valve (112) from cylinder (110).
 - b. Remove cotter pin (102) and pin (133) from link stud (103) and brake band (128).
 - c. Remove cotter pin (102), washers (129) and pin (106). Separate clevis (107) from brake lever (105).
 - d. Remove cotter pin (102) and pin (134). Remove cylinder (110) from bracket (118).
2. Manual Brake:
 - a. Remove cotter pin (102) and pin (133) from handle (104) then remove handle (104) from brake band (128).

Brake Disassembly:

3. Remove capscrews (116), lockwashers (117) and stop plate (126).
4. Use a hoist to raise winch approximately 6 inches (15 cm). Separate brake band (128) halves and rotate brake band assembly slowly until it can be removed from drum (96).
5. Remove cotter pins (102) and pins (101) so brake band halves (128) can be removed from arm (124). Lower winch when brake band assembly has been removed.
6. Refer to 'Brake Lining Instruction Sheet' (Form MDH56142) for brake lining replacement procedures.

Reduction Gear Disassembly (standard)

Refer to Dwg. MHP0568 on page 38.



• It is important to maintain a clean work area when reduction gear assembly is disassembled.

1. Place reduction gear assembly on a clean work bench such that cover (94) is up.
2. Remove capscrews (95) and pry off cover (94).
3. Remove pinion (91), ring gear (92), spacer (90), planet assembly (88) and sun gear (87).
4. Remove and discard 'O' rings (55) from ring gear.
5. Remove four pins (93) from between cover (94) and spacer (90) and store in a safe place.
6. If required, remove thrust plate (86) from sun gear (87).
7. Remove ring gear (85), retainer ring (78) and intermediate planet assembly (84).
8. Remove and discard 'O' ring (55) from ring gear.
9. Remove four pins (89) from between spacer (90) and input housing (82) and store in a safe place.
10. Turn remaining assembly over. Input housing (82) should face down.
11. Remove five capscrews (53) and oil seal support (54).
12. Remove and discard 'O' ring (55) and oil seal (58).
13. Remove output housing (57).
14. Remove bearing (59), thrust plate (62) and spacers (64) and (65).
15. Remove ring gear (67). Remove and discard two 'O' rings (63).
16. Remove three pins (66) from between output housing (57) and input housing (82) and store in a safe place.

17. Remove and discard 'O' ring (61) from planetary support (69).
18. Remove planetary gear assembly (69). Remove retainer rings (76) and (78) and sun gear (77) from assembly.
19. Remove bearing spacer (79) and bearing (81) from input housing (82).

NOTICE

• Do not disassemble planetary gears from their housings unless required to replace damaged parts. For information on planetary assemblies (69), (84) and (88), contact your Ingersoll-Rand distributor or the factory.

Reduction Gear Assembly–Guideline (optional feature)

Refer to Dwg. MHP1708 on page 54.



• It is important to maintain a clean work area when reduction gear assembly is disassembled.

1. Place reduction gear assembly on a clean work bench such that cover (94) is up.
2. Remove capscrews (95) and pry off cover (94).

NOTICE

• There are four pins (93) aligning cover, ring gear and input housing. These do not require removal, and may remain in any of these components.

3. Remove thrust plate (473) and pinion shaft (474).
4. Pull planetary assembly (84) out of ring gear (92). Separate ring gear and discard 'O' rings (55).
5. Remove sun gear (77). Remove thrust bearing (65) from sun gear.
6. Remove capscrews (50) and nuts (83).
7. Separate input housing (82).

NOTICE

• There are three pins (66) aligning input housing, ring gear and output housing. These do not require removal, and may remain in any of these components.

8. Remove bearing spacer (79) and bearing (81) from input housing.
9. Remove planetary support assembly. For disassembly, refer to 'Planetary Support Disassembly' at the end of this section.
10. Separate ring gear (67) and discard 'O' rings (63).
11. Remove bearing (59).
12. Remove capscrews (53) and oil seal support (54). Remove and discard oil seal (58) and 'O' ring (55).

Planetary Support Disassembly:

1. Pull thrust plate (64) from center of planetary support assembly.
2. Remove retainer ring (76). Remove 'O' ring (61) and thrust plate (62) from support. Discard 'O' ring.

NOTICE

- **Planetary support is machined as a set. Matchmark both halves to ensure correct alignment during assembly.**
- **Do not disassemble planetary support or gears unless required to replace damaged parts.**

3. Separate planetary support (69) into individual parts.
4. Remove planet gear shaft (68) with planetary gear assembly. Place on clean shop towel.
5. Slide thrust bearing (75) off shaft (68). Push shaft out of planetary gear.
6. Use shaft to push bearings (73) and spacer (72) out of planetary gear (74).

K5B Motor Disassembly

Refer to Dwg. MHP1714 on page 42.

1. Remove five capscrews (1) from exhaust flange (254). **Do not** remove the two capscrews (255) from throttle valve assembly (260). If equipped with long exhaust flange (254) proceed to step 2; if not, proceed to step 3.
2. Remove four capscrews (257) and lockwashers (154). Lift off control valve (260) and exhaust flange (254) as an assembly.
3. Remove rotary valve housing (247) by pulling it out of motor housing (217) as an assembly with exhaust flange (254).

CAUTION

- **Do not remove the exhaust flange (254) until rotary valve (250) has been removed from rotary valve housing (247).**

4. Remove rotary valve (250) by pulling it out from assembly through the motor housing end of rotary valve housing (247).
5. Remove each cylinder head (201) by removing four capscrews (200). Remove head gasket (209).
6. Pull cylinder liner (208) straight out.
7. Position piston (204) at top of its stroke. In this position, with cylinder liner pulled out in step 6, wrist pin (203) can be removed. Remove one retainer ring (205) from either side of piston (204). Push wrist pin (203) out by hand from one side. If wrist pin is too tight it is acceptable to carefully heat piston to 200° F (93° C) or less and then push wrist pin out.

NOTICE

- **If piston, wrist pin, connecting rod or cylinder liner are to be re-assembled, isolate and number each set. Also add radial alignment marks for each piston and cylinder liner to motor housing.**

8. Remove remaining cylinder liners and pistons as described in steps 6 and 7. To remove crank assembly, all pistons and cylinder liners must be removed.
9. Crank assembly (231) can now be removed with oil slinger (230) by pulling straight out from motor housing (217). Use care while guiding connecting rods (206) through inside of motor housing.

Crankshaft Disassembly:

10. Remove cotter pin (236) and pin nut (237).
11. Remove lock pin (235) by carefully driving it out of its location. Use care not to damage pin threads.
12. Pull crankshaft valve end (231) off crankshaft.
13. Remove connecting rod rings (234), connecting rod bushing (233), sleeve (232) and connecting rods (206). Record the five connecting rod (206) numbers and foot directions so they can be reinstalled in same order.
14. Oil slinger (230) does not have to be removed unless damaged. If removal is required, heating of five screws (229) may be necessary to loosen Loctite® connection.

K5B Motor Live Air Throttle Valve

Refer to Dwg. MHP1719 on page 48.

NOTICE

- **Matchmark throttle valve parts to ensure proper reassembly.**

1. Remove two capscrews (302) and lockwashers (304) that hold the flange (318).
2. Remove two capscrews (302) and lockwashers (304) in valve body retainer (305).
3. Matchmark square end on valve body (316) and handle (300) to ensure correct orientation during reassembly.
4. Drive out pin (301) and remove handle (300).
5. Note spring (303) position before removing it. Pull valve body (316) out of valve bushing (314) while disconnecting spring (303).
6. Remove seal rings (315) from valve body (316).
7. Check parts for score marks or wear.
8. Measure clearance between valve bushing (314) and valve body (316). Clearance between valve bushing and valve body should not exceed 0.002 inch (0.05 mm) or excessive air leakage will occur.

NOTICE

- **Do NOT remove valve bushing (314) from valve housing (311). These components are machined as a matched set. At any indication of wear, replace as an assembly.**

Cleaning, Inspection and Repair

Clean all winch component parts in solvent (except drum brake bands and disc brake friction plates). The use of a stiff bristle brush will facilitate removal of accumulated dirt and sediments on housings, frame and drum. If bushings have been removed it may be necessary to scrape old Loctite® from the bushing bores. Dry each part using low pressure, filtered compressed air. Clean drum brake band using a wire brush or emery cloth. Do not wash drum brake band in solvent. If drum brake band lining is oil soaked, it must be replaced.

Inspection

All disassembled parts should be inspected to determine their fitness for continued use. Pay particular attention to the following:

1. Inspect all gears for worn, cracked, or broken teeth.
2. Inspect all bushings for wear, scoring, or galling.
3. Inspect shafts for ridges caused by wear. If ridges caused by wear are apparent on shafts, replace shaft.

4. Inspect all threaded items and replace those having damaged threads.
5. Inspect drum band brake lining for oil, grease and glazing. If drum band brake lining is oil-soaked replace brake bands as a set. Remove glazed areas of band brake lining by sanding lightly with a fine grit emery cloth.
6. Measure thickness of the drum band brake lining. If drum brake band linings are less than 0.062 inch (2 mm) thick anywhere along edges replace brake bands (128) as a set.
7. Inspect cylinder bores. Minor scratches in bore lining may be repaired by lightly honing to remove. Refer to tolerances listed below for acceptable clearances. Replace liner if deep scratches or gouges are apparent. Measure inside diameter of liner. If measurement is greater than 4.764 inches (121 mm) replace liner. 'Ring Gap' may also be used to determine wear; place compression ring into liner, using a piston, push ring until approximately half way in liner and measure the 'Gap' — 0.003 inch (0.076 mm) is normal; replace rings, or liner, if 'Gap' exceeds 0.020 inch (0.51 mm).

Repair

Actual repairs are limited to removal of small burrs and other minor surface imperfections from gears and shafts. Use a fine stone or emery cloth for this work.

1. Worn or damaged parts must be replaced. Refer to the applicable parts listing for specific replacement parts information.
2. Inspect all remaining parts for evidence of damage. Replace or repair any part which is in questionable condition. The cost of the part is often minor in comparison with cost of redoing job.
3. Smooth out all nicks, burrs, or galled spots on shafts, bores, pins, or bushings.
4. Examine all gear teeth carefully, and remove nicks or burrs.
5. Polish edges of all shaft shoulders to remove small nicks which may have been caused during handling.
6. Remove all nicks and burrs caused by lockwashers.

Assembly

General instructions

- Use all new gaskets and seals.
- Replace worn parts.
- Assemble parts using match marks attached during disassembly. Compare replacement parts with originals to identify installation alignments.
- Lubricate all internal parts with rust and oxidation inhibiting lubricant, ISO VG 100 (SAE 30W).

Thermoplastic Coated Parts Assembly

CAUTION

• During application of thermoplastic coating to assemblies use a flame to localize the heat. Do not heat entire assembly. Assemblies contain gaskets, 'O' rings and other components that may be damaged by exposure to excessive heat.

1. When assembling parts already coated, the mating areas can be heated to soften the coating enough to flow together and seal the parts.

2. When installing a new component in an assembly, remove coating from existing parts as necessary to ensure parts mate correctly.
3. Install fasteners and torque as required. Apply coating to bare areas as described in 'Thermoplastic Coating' repairing surfaces instructions in the "MAINTENANCE" section for areas larger than 1/16 inch (1.6 mm).
4. Allow the repaired area to cool. Quenching with water is acceptable. Rough spots, minor scorching and excess coating deposits can be wet sanded to remove the imperfections. To return the gloss finish, reheat the surface carefully.

K5B Motor Live Air Throttle Valve Assembly

Refer to Dwg. MHP1719 on page 48.

NOTICE

• During assembly align parts using matchmarks made during disassembly.

1. Install seal rings (315) on each end of valve body (316).
2. Install valve body (316) into valve bushing (314).
3. Install valve body retainer (305) with two capscrews (302) and lockwashers (304). Torque capscrews to 25 ft lbs (34 Nm).
4. If removed, reinstall spring retaining stud (306) and torque to 25 ft lbs (34 Nm).
5. Install spring (303) and handle (300) on square shaft of valve body (316). Spring (303) ends must straddle spring retaining stud on throttle handle. Install roll pin (301).
6. Check throttle handle moves fully left and right without sticking or binding. Throttle handle should center, by spring force, automatically when released.
7. Secure flange (318) and gasket (317) with lockwashers (304) and capscrews (302).

K5B Motor Assembly

Refer to Dwg. MHP1714 on page 42.

1. Assemble throttle valve assembly (260), gasket (248) and exhaust flange (254) to rotary valve housing (247) using four capscrews (257) and lockwashers (154). Install two capscrews (255) and lockwashers (154) that attach exhaust flange (254) to throttle valve housing.
2. Tighten capscrews (255) and (257) to 25 ft lbs (34 Nm). Throttle handle should move fully left and right without sticking or binding, and should center (by spring force) automatically when released.
3. Assemble bearing (252) to rear of rotary valve (250) by pressing only on inner race of bearing. Install four seal rings (251) into grooves in rotary valve (250). Compress rings with a band ring compressor. With exhaust flange (254) down install rotary valve, bearing first, into rotary valve housing (247) until bearing is seated.
4. Install 'O' ring (244) into motor housing (217).
5. Install rotary valve housing gasket (243) onto rotary valve housing (247). With exhaust flange down on bench, install motor housing (217) onto rotary valve housing. Check for any evidence of damage to 'O' ring when rotary valve housing is fully engaged. Install and tighten capscrews (1) to 50 ft lbs (68 Nm).
6. If removed, press crank bearing (228) on crank assembly (231). Apply pressure only on inner race of bearing.

7. Place crank assembly (231) on a work bench with oil slinger (230) down and slide the sleeve (232) (with tang up) on crankpin.
8. Slide connecting rod bushing (233) over sleeve (232) and first connecting rod ring (234) with chamfer up.
9. Install connecting rods (206) in same order as removed, with all feet pointing in same direction, using first connecting rod ring (234) to hold one side of connecting rod feet.
10. Slide second connecting rod ring (234) over other side of connecting rod feet with chamfer on ring facing down (toward stem of connecting rod).
11. Slide crank shaft valve end over crank pin while simultaneously aligning tang on sleeve (232) with slot in crank shaft.
12. Rotate and position crank shaft valve end relative to crank pin to allow installation of lock pin (235).
13. Tap lock pin (235) in place and install pin nut (237). Torque nut to 60 ft lbs (81 Nm).
14. Install cotter pin (236) and bend ends over.
15. Install roll pin (240) and bearing (228) into valve end of crank shaft.
16. Check that all connecting rods move freely around crank. Position crank assembly (231) into motor housing (217). Ensure bearing (228) is seated and connecting rods (206) are centered in cylinder holes.

NOTICE

- **Make certain roll pin (240) and three lugs on rotary valve (250) line up with corresponding hole and lugs on crank shaft.**
- **Do not allow rotary valve (250) to slide back in rotary valve housing (247). If rotary valve slides in too far, seal ring (251) will lock-up in internal grooves of rotary valve housing (247) and restrict further assembly.**

17. Rotating crank assembly, position one connecting rod (206) at the top of its stroke. Install a piston (204) with its rings (202) and (207) to connecting rod with wrist pin (203) and retaining rings (205).
18. Install a new cylinder head gasket (209) before installing cylinder liner (208).
19. Install cylinder liner (208) over the piston (204) by compressing both piston rings (202) and (207) and with a single band ring compressor.
20. Install cylinder head (201) over cylinder and secure cylinder head to motor housing (217) with four capscrews (200). Torque capscrews to 60 ft lbs (81 Nm).
21. Repeat Steps 17 through 20 for remaining cylinders.
22. Rotate motor by hand. Motor should rotate without binding.
23. Install mounting flange (216) and gasket (226) on front of motor housing (217). Make sure notches on both parts are aligned.
24. Lightly lubricate 'O' ring (5) and install in groove on motor adapter (6).

NOTICE

- **'O' ring, item 5 listed in step 24 refers to part number 51459 as shown on winch assembly Dwg. MHP0568 on page 38. This part must be placed between mounting flange (216) and motor adapter (6).**

25. Temporarily install capscrews and nuts finger tight to retain motor adapter (6).

26. Install eye bolts (213) and vent cap assembly (210) in motor housing (217).
27. Ensure oil drain and level plugs are installed.

Reduction Gear Assembly (standard)

Refer to Dwg. MHP0568 on page 38.

NOTICE

- **It is important to maintain a clean work area when reduction assemblies are reassembled. During reassembly clean each part thoroughly and lightly coat with appropriate lubricant as described in 'Recommended Lubricants' on page 16 of the "LUBRICATION" section.**

1. Install bearing (81) and retainer ring (79) in input housing (82).
2. Install sun gear (77) in planetary gear assembly (69). Install retainer rings (76) and (78).
3. Install planetary gear assembly (69) in input housing (82).
4. Install new 'O' ring (61) on planetary support (69).
5. Install three pins (66) in input housing (82). Install two new 'O' rings (63) on ring gear (67). Align pin holes and install on input housing.
6. Install spacers (64) and (65) in sun gear (77).
7. Install thrust plate (62).
8. Install bearing (59) and oil seal (58) on planetary support (69).
9. Align pin holes and install output housing (57).
10. Install new 'O' ring (55) and oil seal support (54). Secure with five capscrews (53). Apply Loctite® 242 to capscrew threads and torque to 18 ft lbs (24 Nm).
11. Place a bead of Loctite® 515 sealant on output housing (57) mating surface to drum adapter (52) to provide seal between parts. Sealant should be applied inside of capscrew pattern.
12. Align holes in output housing (57) with drum adapter (52) and install eighteen capscrews (50). Apply Loctite® 242 to capscrew threads. Capscrews must protrude through holes in input housing (82). Install nuts (83) on capscrews and torque to 58 ft lbs (78 Nm).
13. Position assembly with drum adapter down.
14. Align gears and install planetary assembly (84) onto sun gear (77).
15. Install two new 'O' rings (55) and four pins (89) on ring gear (85). Position pins with an equal amount extending from each side of ring gear. Align pins with input housing (82) holes and install.
16. Install thrust plate (86) in sun gear (87) and install sun gear into planetary assembly (84).
17. Install planetary assembly (88) on pinion (91).
18. Install pinion (91) on sun gear (87).
19. Align pin holes and install spacer (90) on ring gear (85).
20. Install two new 'O' rings (55) and four pins (93) on ring gear (92). Position pins with an equal amount extending from each side of ring gear. Align pins with spacer (90) holes and install.
21. Align pin holes and install cover (94). Apply Loctite® 242 to eight capscrew (95) threads and install. Torque capscrews to 32 ft lbs (44 Nm).
22. Ensure four plugs (56) are threaded fully into input housing (82) and that fit is tight.
23. Place a bead of Loctite® 515 sealant on drum (96) mating surface with drum adapter (52) to provide a seal between the two. Sealant placement should be outside of capscrew pattern.

- Align holes in drum adapter (52) with drum (96). Install two pins (51). Apply Loctite® 242 to eight capscrew (45) threads and, with lockwashers (46), install. Torque capscrews to 250 ft lbs (340 Nm).

Winch Assembly

Refer to Dwg. MHP0568 on page 38.

- Clean both mating surfaces on inboard upright (42) and install drum shaft (41) through bore aligning dowel pin holes.
- Install dowel pins (40) flush or slightly below surface of drum shaft (41).
- Install eight capscrews (39). Lightly coat capscrew threads with Loctite® 242 and torque to 125 ft lbs (170 Nm).
- Install 'O' ring (43) on drum shaft (41).
- Align gears and slide drum (96), with reduction gear assembly installed, onto inboard upright (42) and drum shaft (41) assembly.
- Clean seal surface and install oil seal (187) in outboard upright (184) with lip toward drum.
- Pack bearing (188) with grease and install in outboard upright (184).
- Install outboard upright (184) on drum end. Ensure assembly is kept centered on seal and journal during this step.
- Install shaft retainer (191). Secure with three capscrews (192). Coat capscrew threads with Loctite® 242 and torque to 30 ft lbs (41 Nm).
- Install spacer (189).
- Apply Loctite® 515 sealant to mating surface outboard upright (184) and install end cover (193). Coat capscrew (196) threads with Loctite® 242 and, with lockwashers (154), install to secure cover (193). Torque to 30 ft lbs (41 Nm).
- Coat threads with Loctite® 242 and install plug (195) in end cover (193).
- Install side rails (98) and (99) to uprights (42) and (184). Loosely secure with capscrews (116) and lockwashers (181).
- Tap dowel pins (51) into position through side rails, into uprights, until flush with side rails.
- Tighten eight capscrews (116), installed in step 13, evenly and torque to 140 ft lbs (190 Nm).
- Press bearing (37) onto shaft (35). Lightly coat inner bearing race bore with Loctite® 609. Install retainer ring (38).
- Install shaft and bearing into drum shaft (41) so smaller splined end enters first. Install retainer ring (36) in bore of drum shaft (41).

Instructions 18 through 29 cover winches with a disc brake. For winches without a disc brake skip to instruction 29.

- Install spacer (34) on shaft (35). Install splined hub (19) so splined side on outside diameter goes on first. Install capscrew in locking ring (18) and place on shaft (35). Maintain pressure on locking ring to keep it against splined hub (19) and tighten capscrew in locking ring (18).
- Lubricate and install 'O' ring (33) on hub of drum shaft.
- Install brake housing (21) on drum shaft (41) being careful not to damage 'O' ring (33).
- Position brake housing (21) so brake port is in the 2 o'clock position (as viewed from the motor end). Install drain plug (24) in brake housing at the 6 o'clock position.
- Install fitting (22) and breather (23) in top of brake housing.

- Lubricate friction plates (16) with a light motor oil (refer to 'Recommended Lubricants' on page 16 in "LUBRICATION" section). Install friction plates (16) and drive plates (17) in brake housing. Begin with a friction plate then alternate with drive plates between friction plates. Ensure splined teeth mesh. Do not force plates into place during installation.
- Lubricate and install seals (11) and (12) in brake piston (10) grooves so seal lips face each other. Do not overstretch seals during this procedure. Refer to Dwg. MHP0139 on page 33.

Brake Seal Installation

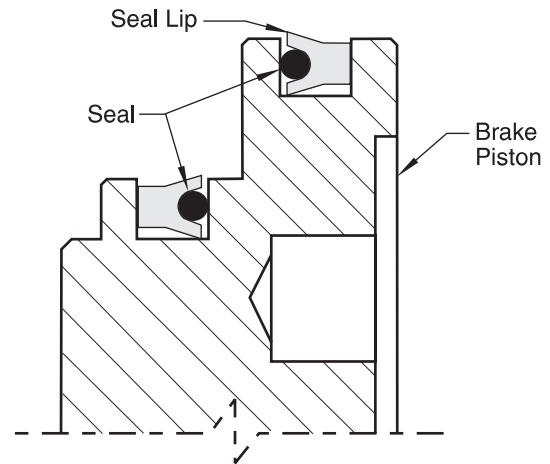

(Dwg. MHP0139)

- Install brake piston assembly in brake housing so stepped side enters first. Gently tap into position using a soft mallet until seated.
- Install one brake spring (9) in each brake spring holes.
- Lubricate and install 'O' ring (47) in groove on brake housing (21).

NOTICE

• 'O' ring, item 47 listed in step 27 refers to part number 51460 as shown on disc brake Dwg. MHP0152 on page 44. This part must be placed between brake housing (21) and motor adapter (6).

- Install brake reaction plate (8) in motor adapter.
- Install seal adapter (15) in mounting flange (216), if required.

NOTICE

• Two threaded holes in motor adapter (6) are centered between mounting bolt holes. Install motor adapter with these two holes in 6 o'clock position.

- Secure motor adapter (6) with capscrews (1) for disc brake units or capscrews (4) for units without disc brake. Coat capscrew threads with Loctite® 242 before installing. Torque to 125 ft lbs (170 Nm). On winches with a disc brake install capscrews evenly to compress brake springs, and torque to 80 ft lbs (108 Nm). Do not allow plate to become cocked. Evenly hand tighten all capscrews before applying final torque.
- On disc brake equipped winches install shaft extender (7) on end of shaft (35). On winches without disc brake install seal sleeve (14) on shaft (35).

32. Lubricate and install 'O' ring (5) in groove on motor adapter (6).
33. Ensure seal adapter (15) and oil seal (2) are installed in bore of motor assembly. Seal lip must face into motor assembly.

⚠ WARNING

• **The air motor weighs approximately 260 lb. (118 kg). Adequately support air motor while installing motor mounting capscrews.**

34. If motor assembly is being mounted with winch in a vertical position, install one short bolt and nut to keep motor mounting flange from dropping off. Lower motor assembly carefully onto the shaft. Position throttle assembly at the top. Be careful not to damage oil seal (2). When correctly positioned remove bolt and nut and lower motor assembly the remaining distance.
35. Install the motor assembly to motor mounting plate using capscrews (4) and lockwashers (3). Lightly coat capscrew threads with Loctite® 242 and torque to 85 ft lbs (115 Nm).
36. Ensure seal sleeve is in place in drum shaft (41). Due to very thin wall section, use extreme care to prevent damage to the seal sleeve.
37. On winches with a disc brake, install fitting (31) in dump valve (30) and screw into brake release port. Install vented fitting (29) in dump valve (30). Install fitting (25) in valve assembly (260) with elbow (26). Install steel tube (27) between fitting on dump valve (30) and elbow (26).
38. Mount winch to foundation as described in 'Mounting' on page 8 in the "INSTALLATION" section.

Drum Brake Assembly

Ref. Dwg. MHP1876 on page 46.

1. Install pivot bracket (122) on end of arm (124) with pin (121) and cotter pins (102). Recessed side of threaded hole must be toward brake band side.
2. Install connecting link (125) on arm (124) and secure in position with pin (121), washer (123) and cotter pin (102). Bend ends of cotter pin over to secure. Assemble connecting link (125) so curved surface matches contour of brake band.
3. Install halves of brake band (128) to connecting link and secure with pins (101) and cotter pins (102). Bend ends of cotter pin over to secure.
4. Lift winch assembly, with a suitable hoist, approximately 6 inches (15 cm) off floor or work bench.
5. Position brake band subassembly around brake diameter on drum (96) until arm (124) lays at bottom. When positioned, lower winch.
6. Mount pivot bracket (122) on inside surface of side rail (99) and secure in position with capscrews (116) and lockwashers (117).
7. Screw link stud (103) into handle (104) and install handle (104) in lug on end of brake band (128). Lubricate pivot points being careful not to get grease on brake band lining.
8. Pull halves of brake band together and install pin (133) through lug on band (128) and link stud (103) on handle assembly.
9. Install stop plate (126) on inside of side rail (98) with capscrews (116) and lockwashers (117). Install adjusting screw (127) and locknut (120) through side rail (98) and stop plate (126) until it contacts arm (124).
10. Adjust brake as described under 'Adjustments' on page 25 in "MAINTENANCE" section.

Automatic Drum Brake Actuator Assembly:

11. Install bracket (118) on side rail (99) with capscrews (116) and lockwashers (117).
12. Screw nut (108) and clevis (107) onto cylinder rod. Screw nut (108) down until there is approximately 1 ¼ to 1 ½ inch (32 to 38 mm) between nut and top of cylinder.
13. Attach brake lever (105) to brake band (128).
14. Install cylinder (110) so it connects with bracket (118) and brake lever (105). Use pins (106) and (134), washers (129) and cotter pins (102) to secure in position.
15. Install dump valve (112), fittings and hose (113) and (115) to the cylinder (110).
16. Adjust automatic brake as described under 'Adjustments' on page 25 in the "MAINTENANCE" section.

Testing

Operational Test

Prior to initial use, all new or repaired winches shall be tested to ensure proper operation.

1. Check oil level in motor, reduction gear assembly and disc brake are correct. Top off levels as required before operation as described in the "LUBRICATION" section.
2. To initially 'break in' new or overhauled motors operate without load, in both directions, for 15 minutes at 100 - 200 RPM.
3. New Drum Brake Band Lining Run-in Procedure: All new drum brake band linings require a 'run-in' period. Operate the winch without load in the payout direction while gradually applying the brake. Allow the brake to slip for approximately one minute. Winch motor may stall as drum brake band lining fully engages. Do not allow brake to overheat.
4. Check operation of brakes. Adjust if necessary as described in the "MAINTENANCE" section.
5. Check operation of limit switches, locking mechanisms and all safety devices when equipped.
6. Check foundation mounting fasteners are secure.
7. Install drum guard when provided.

Load Test

Prior to initial use, all new or extensively repaired winches shall be load tested by or under the direction of a person trained in safety and operation of this winch and a written report furnished confirming the rating of winch. Test loads shall not be less than **100%** of rated line pull and should not exceed **125%** of rated line pull.

To test winch at **125%** of rated load apply following load with wire rope on the first layer of the drum:

FA7 Winch	29,076 lb. (13189 kg)
FA7T and TPL Winch	28,500 lb. (12928 kg)
FA7TGL Winch	9,750 lb. (4423 kg)

NOTICE

• **Testing to more than 125% of rated line pull may be required to comply with standards and regulations set forth in areas outside of the USA.**

Limit Switches

Operate winch through three complete cycles to ensure consistent limit switch operation within +/- 2 feet (0.6 metre) of setpoints. Refer to 'Limit Switch Adjustment' on page 27 in "MAINTENANCE" section to establish setpoints.

FA7 WINCH ASSEMBLY DRAWINGS REFERENCE DIAGRAM

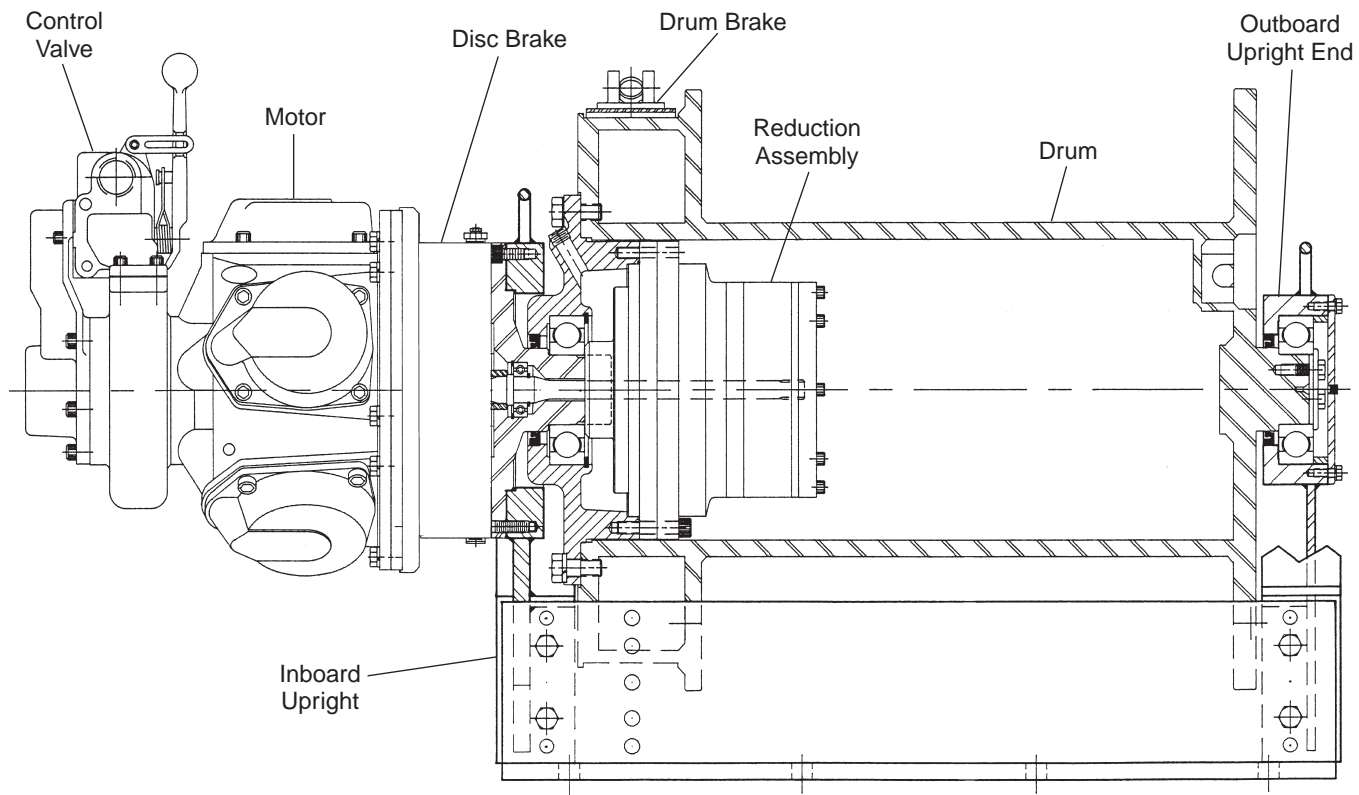

(Dwg. MHP0179)

FA7 WINCH DRAWINGS AND PARTS LISTS TABLE OF CONTENTS

Description	Page No.
FA7 Winch Assembly Reference Drawing (MHP0179)	36
Drum, Base and Reduction Gear Assembly Drawing (MHP0568)	38
Drum, Base and Reduction Gear Assembly Drawing Parts List	39
Drum, Base and Reduction Gear Assembly Drawing Parts List (continued)	40
Muffler Assembly Drawings (MHP0570) and Parts List.	41
K5B Motor Assembly Drawing (MHP1714)	42
K5B Motor Assembly Parts List	43
Disc Brake Assembly Drawing (MHP2021)	44
Disc Brake Assembly Parts List	45
Drum Brake Assembly Drawing (MHP1876)	46
Drum Brake Assembly Parts List	47
Live Air Control Valve Assembly Drawing (MHP1719) and Parts List	48
Pilot Air Control Valve (optional) Assembly Drawing (MHP0141) and Parts List.	49
Remote Live Air Control Assembly Drawing (MHP1489) and Parts List	50
Pendant Control Assembly Drawing (MHP0993) and Parts List	51
Remote Pilot Air Control (optional) Assembly Drawing (MHP1490) and Parts List	52
Drum Locking Pin (optional) Assembly Drawing (MHP1237) and Parts List	53
Guideline Reduction Gear Assembly Drawing (MHP1708)	54
Guideline Reduction Gear Assembly Parts List	55
Guideline Control Valve Assembly Drawing (MHP1329)	56
Guideline Control Valve Assembly Parts List	57
Drum Guard Assembly Drawing (MHP0205) and Parts List	58
Guideline Control Valve Assembly Drawing (MHP1327) and Parts List	59
Emergency Stop Valve and Overload Assembly Drawing (MHP1488)	60
Emergency Stop Valve and Overload Assembly Parts List	61
Emergency Stop Valve and Overload Assembly Drawing (MHP1341) and Parts List	62
Remote Pendant with Emergency Stop Assembly Drawing (MHP1709) and Parts List.	63
Limit Switch Assembly Drawing (MHP1866)	64
Limit Switch Assembly Parts List	65
Pilot Air Valve Plumbing Assembly Drawing (MHP1716)	66
Pilot Air Valve Plumbing Assembly Parts List.	67
Tension Manifold Assembly Drawing (MHP1870)	68
Tension Manifold Assembly Parts List.	69
Air Preparation Assembly Drawing (MHP0223) and Parts List.	70
Kits and Accessories Parts List.	71
Labels and Tags Replacement Drawing (MHP1445) and Parts List	71
Common Parts List	72
Parts Ordering Information	74
Warranty	75

DRUM, BASE AND REDUCTION GEAR ASSEMBLY DRAWING

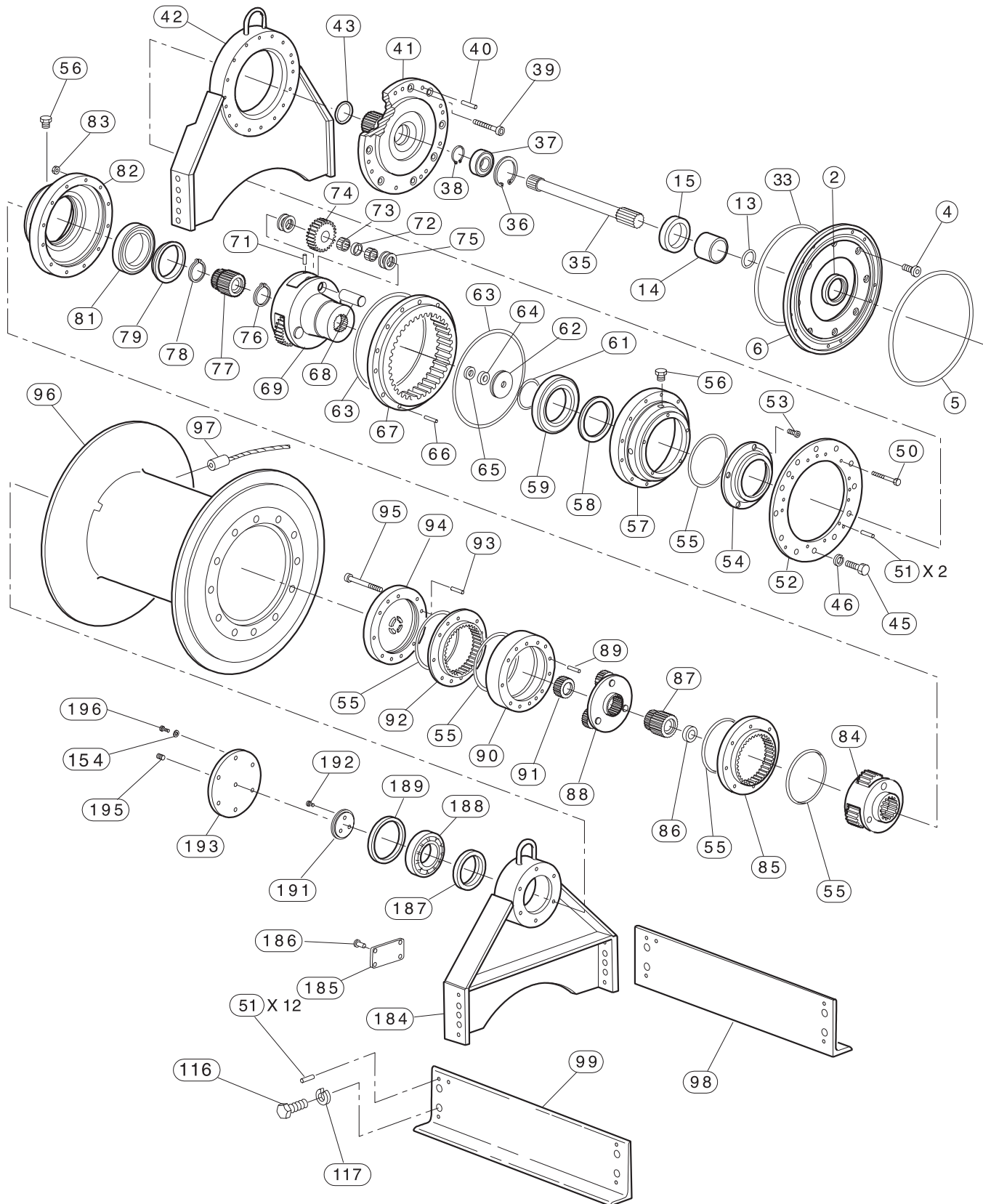

(Dwg. MHP0568)

DRUM, BASE AND REDUCTION GEAR ASSEMBLY PARTS LIST

ITEM NO.	DESCRIPTION OF PART	QTY. TOTAL	PART NUMBER	ITEM NO.	DESCRIPTION OF PART	QTY. TOTAL	PART NUMBER	
• 2	Oil Seal	1	51873	74	Planetary Gear	3	Order Item 49	
4	Capscrew	8	52379	75	Thrust Bearing	6		
• 5	'O' Ring	1	51459	76	Retainer Ring	1	71138986	
6	Motor Adapter	1	14227	77	Sun Gear	1	71139083	
• 13	'O' Ring (Drive Shaft)	1	54462	78	Retainer Ring	1	71068597	
14	Sleeve	1	10598	79	Bearing Spacer	1	71139042	
15	Seal Adapter	1	16354	81	Bearing, Ball	1	71138960	
33	'O' Ring	1	51460	82	Input Housing	1	71138911	
35	Shaft, Drive †	1	10903	83	Nut	18	71112288	
36	Retainer Ring	1	52298	84	Planetary Assembly	1	71139141	
37	Bearing	1	51870	85	Ring Gear	1	71138879	
38	Retainer Ring	1	51872	86	Thrust Plate	1	71068647	
39	Capscrew	8	52380	87	Sun Gear	1	71139075	
40	Pin, Dowel	2	52334	88	Planetary Assembly	1	71107627	
41	Drum Shaft †	1	14168	89	Pin	4	71068472	
42	Upright, Inboard †	1	**	90	Spacer	1	71068522	
• 43	'O' Ring	1	71032627	91	Pinion	1	71107635	
45	Capscrew	12	52829	92	Ring Gear	1	71068514	
46	Lockwasher	12	51012	93	Pin	4	71068464	
49	Reduction Gear Assembly*	1	51875	94	Cover	1	71068654	
50	Capscrew	18	71112270	95	Capscrew	8	71106736	
51	Dowel Pin	14	51468	96	Drum	1	**	
52	Adapter	1	10803	97	Wire Rope Anchor, 3/4 inch	1	52000	
53	Capscrew	5	71138994		Wire Rope Anchor, 7/8 inch		52308	
54	Oil Seal Support	1	71138937		Wire Rope Anchor, 1 inch		52325	
• 55	'O' Ring	5	52149	98	Side Rail, Outboard	1	**	
56	Plug	8	71068571	99	Side Rail, Inboard			
57	Output Housing	1	71138929	116	Capscrew	8	71128193	
58	Oil Seal	1	71139117	117	Lockwasher	8	51008	
59	Bearing Ball	1	71138979	154	Lockwasher	6	50200	
• 61	'O' Ring	1	71139125	184	Upright, Outboard †	1	**	
62	Thrust Plate	1	71138861	185	Nameplate	1	71106967-R	
• 63	'O' Ring	2	71139133	186	Rivet	4	50915	
64	Spacer	1	71139109	187	Seal	1	51463	
65	Spacer	1	71139091	188	Bearing	1	51455	
66	Pin	3	71139026	189	Spacer	1	15458	
67	Ring Gear	1	71138887	191	Shaft Retainer	1	15457	
68	Shaft, Planet Gear	3	Order Item 49	192	Capscrew	3	51086	
69	Planetary Gear Assembly	1		193	End Cover	1	15459	
71	Pin	3		195	Plug	1	54246	
72	Spacer	3		196	Capscrew	6	51780	
73	Bearing, Roller	204		74	Planetary Gear	3		
•	Recommended spare for one winch, 2 years of normal operation.							

* Reduction Gear Assembly includes item numbers 53–82 and 84–95. For Guideline winches refer to Guideline Reduction Gear Assembly Dwg. MHP1708 on page 54.

** Refer to UPRIGHT ASSEMBLY PARTS LIST, DRUM ASSEMBLY PARTS LIST and SIDE RAIL ASSEMBLY PARTS LIST for parts information. RH = Right Hand Side, LH = Left Hand Side as viewed from the winch motor end. Inboard is end closest to motor; outboard is end farthest away from motor.

† These parts also come in a cold weather version. For winches with a —C in the model code, adding CH to the end of these part numbers is required to retain winch certification. Example: Order Drive Shaft (item 35) part number 10903 as part number 10903CH.

DRUM, BASE AND REDUCTION GEAR ASSEMBLY PARTS LIST (CONT'D)

UPRIGHT ASSEMBLY PARTS LIST

INBOARD UPRIGHT (ITEM 42)	QTY TOTAL	PART NUMBER	OUTBOARD UPRIGHT (ITEM 184)	QTY TOTAL	PART NUMBER
Standard †	1	10787	Standard †	1	10788
Guideline and Podline†	1	25759	Guideline and Podline†	1	25761

DRUM ASSEMBLY PARTS LIST

DRUM (ITEM 96) WITH BAND BRAKE	QTY TOTAL	PART NUMBER	DRUM (ITEM 96) WITHOUT BAND BRAKE	QTY TOTAL	PART NUMBER
-----------------------------------	--------------	-------------	--------------------------------------	--------------	-------------

Drum - Standard Flange Height (30 inches):

Drum (24 inches long) †	1	10800-5	Drum (24 inches long) †	1	10815-5
Drum (30 inches long) †		10800-6	Drum (30 inches long) †		10815-6
Drum (36 inches long) †		10800-12	Drum (36 inches long) †		10815-10

Drum - Tall Flange Height (36 inches):

Drum (24 inches long) †	1	17689-5	Drum (24 inches long) †	1	17602-5
Drum (30 inches long †)		17689-6	Drum (30 inches long †)		17602-6
Drum (36 inches long †)		17689-12	Drum (36 inches long †)		17602-7
Drum (42 inches long) †		17689-11	Drum (42 inches long) †		17602-8
Drum (55 inches long) †		contact factory	Drum (55 inches long †)		contact factory

Drum - Guideline and Podline (no Drum Lock):

Drum (24 inches long) †	1	25754-5
Drum (30 inches long) †		25754-6
Drum (36 inches long) †		25754-10
Drum (42 inches long) †		25754-8
Drum (55 inches long) †		contact factory

SIDE RAIL PARTS LIST

SIDE RAIL (ITEM 98) OUTBOARD	QTY TOTAL	PART NUMBER	SIDE RAIL (ITEM 99) INBOARD	QTY TOTAL	PART NUMBER
---------------------------------	--------------	-------------	--------------------------------	--------------	-------------

Side Rail for drum with band brake:

with 24 inch Drum †	1	10902-5	with 24 inch Drum †	1	10901-5
with 30 inch Drum †		10902-6	with 30 inch Drum †		10901-6
with 36 inch Drum †		10902-12	with 36 inch Drum †		10901-12
with 42 inch Drum †		10902-11	with 42 inch Drum †		10901-11
with 55 inch Drum †		contact factory	with 55 inch Drum †		contact factory

Side Rail for drum without band brake:

with 24 inch Drum †	2	11407-5	with 24 inch Drum †	1	26054-5
with 30 inch Drum †		11407-6	with 30 inch Drum †		26054-7
with 36 inch Drum †		11407-7	with 36 inch Drum †		26054-8
with 42 inch Drum †		11407-8	with 42 inch Drum †		26054-11
with 55 inch Drum †		contact factory	with 55 inch Drum †		contact factory

Side Rail for Guideline and Podline:

† These parts also come in a cold weather version. For winches with a -C in the model code, adding CH to the end of these part numbers is required to retain winch certification. Example: Order Drum (24 inches long) (item 96) part number 10800-5 as part number 10800-5CH.

MUFFLER ASSEMBLY DRAWINGS AND PARTS LIST

K5B Motor Muffler Live Air Throttle Valve with Long Exhaust Manifold

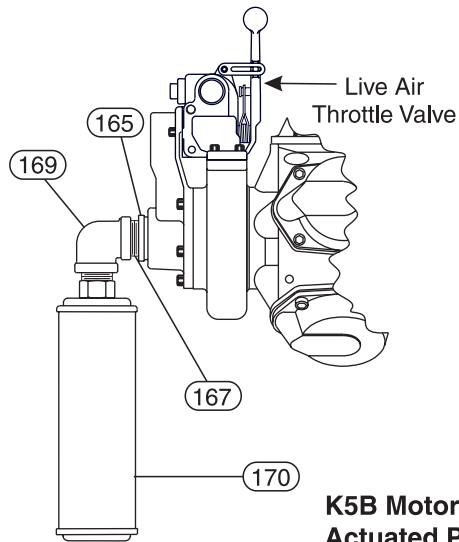

K5B Motor Muffler Live Air Throttle Valve with Round Exhaust Manifold

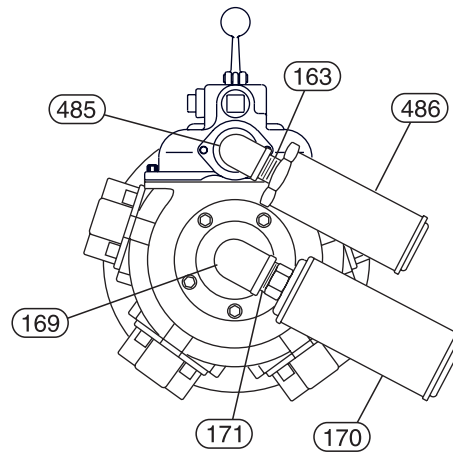

K5B Motor Mufflers with Remote Actuated Pilot Control Valve

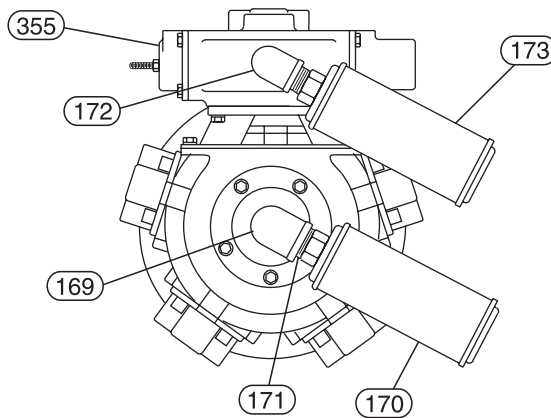

(Dwg. MHP0570)

ITEM NO.	DESCRIPTION OF PART	QTY TOTAL	PART NUMBER	ITEM NO.	DESCRIPTION OF PART	QTY TOTAL	PART NUMBER
K5B Motor with Live Air Throttle Valve							
165	Reducer Bushing	1	71057459	169	Pipe Elbow	1	71057434
167	Pipe Nipple	1	71057467	170	Muffler	1	50594
K5B Motor with Remote Actuated Pilot Valve							
163	Pipe Nipple	1	71057483	173	Muffler	1	52465
169	Pipe Elbow	1	71057434	355	Valve Assembly	1	20993
170	Muffler	1	50594	485	Pipe Elbow	1	54513
171	Pipe Nipple	1	51704	486	Muffler	1	71264360
172	Pipe Elbow	1	71127484				

K5B MOTOR ASSEMBLY DRAWING

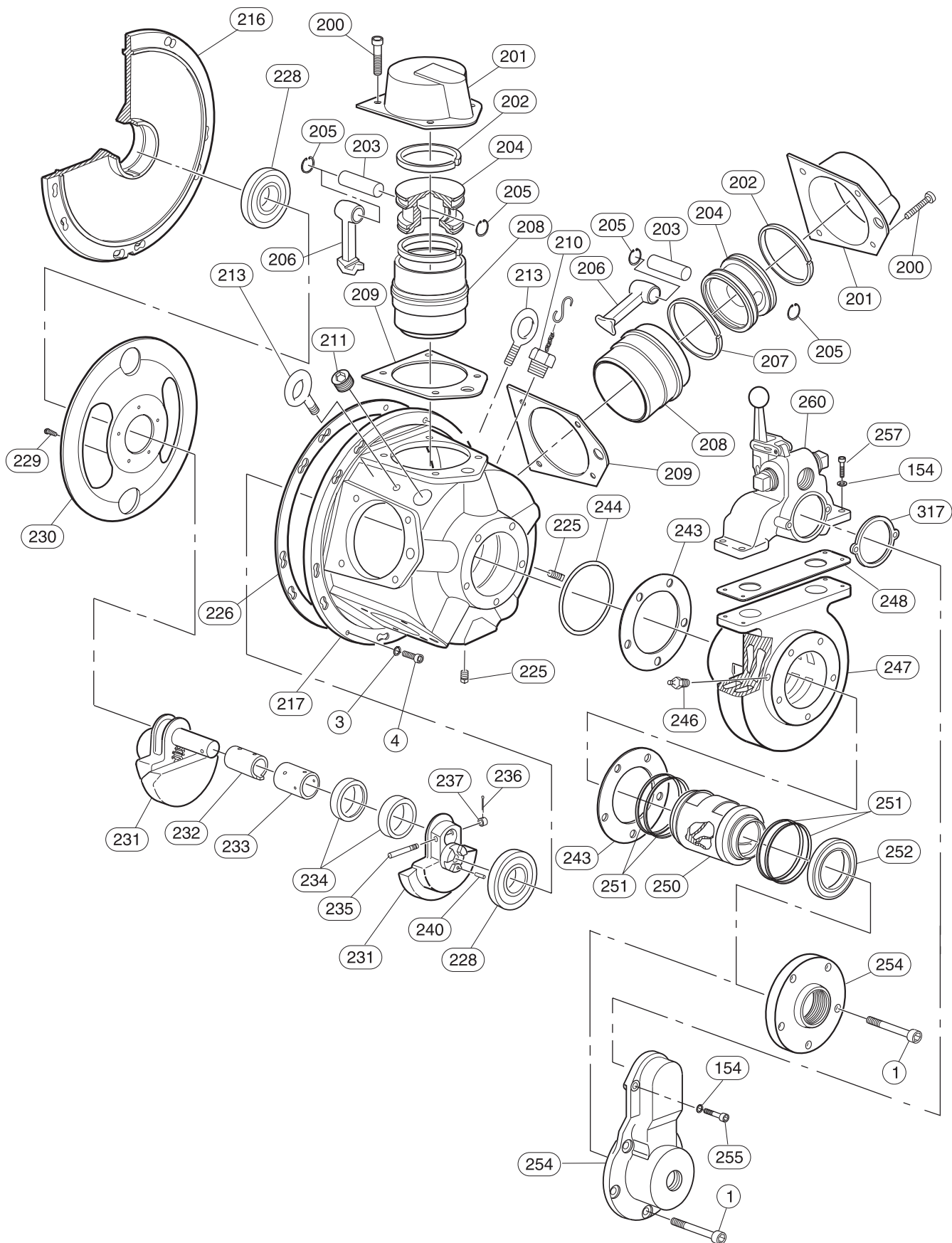

(Dwg. MHP1714)

K5B MOTOR ASSEMBLY PARTS LIST

ITEM NO.	DESCRIPTION OF PART	QTY TOTAL	PART NUMBER	ITEM NO.	DESCRIPTION OF PART	QTY TOTAL	PART NUMBER
199	Motor Assembly **	1	K5B-546	229	Button Head Screw	5	K5B-541
	with Control Valve			230	Oil Slinger	1	K5B-540
	without Control Valve			231	Crank Shaft Assembly	1	K5B-A516
1	Capscrew	5	51471	232	Sleeve	1	K5B-519
3	Lockwasher	10	50181	233	Bushing	1	K5B-511
4	Capscrew	10	52379	234	Connecting Rod Ring	1	K5B-510
154	Lockwasher	6	50200	235	Lock Pin	1	HU-520
200	Capscrew	20	52317	236	Cotter Pin	1	53456
201	Cylinder Head	5	K5B-H505	237	Pin Nut	1	D02-394
202	Compression Ring	1 Set	K5B546-KRING	240	Roll Pin	1	54257
203	Wrist Pin	5	HU-514A	243	Gasket	2	K5B-928
204	Piston *	Order item 261		244	'O' Ring	1	20A11CM248
205	Retainer Ring	10	902A45-632	246	Grease Fitting	1	53095
206	Connecting Rod	5	K5B-509	247	Rotary Valve Housing	1	K5B-545
207	Oil Ring	Order Item 202		248	Gasket	1	K5B-547
208	Cylinder Liner	5	K5B-L505-47	250	Rotary Valve Assembly	1	K5B-526EQ-RS
209	Head Gasket	1 Set	K5B-507-5	• 251	Seal Ring Assembly	1 set	K5B-607A
210	Vent Cap Assembly	1	26604	252	Bearing	1	50138
211	Pipe Plug	1	71263297	254	Exhaust Flange Round	1	KK5B-276M
213	Eye Bolt	2	KU-888		Exhaust Flange Long		K5B-276
216	Mounting Flange	1	K5B-502A	255	Capscrew	2	71326110
217	Motor Housing	1	K5B-501A	257	Capscrew	4	51766
225	Pipe Plug (Drain)	2	54912	260	Control Valve Assembly	1	K5B-REMOTE
226	Gasket	1	K5B-592				
228	Crank Bearing	2	51066	317	Gasket	1	K5B-275

• Recommended spare for one winch, 2 years of normal operation.

* Parts not sold separately. Refer to "K5B Motor Assembly Kit List"

** Motor Assembly (item 199) consists of items 200 through 260 and 317.

K5B Motor Assembly Kit List:

ITEM NO.	DESCRIPTION OF PART	QTY TOTAL	PART NUMBER
231	Crank Assembly (Includes items 206 and 228 through 240)	1	K5B-A516
250	Rotary Valve Assembly (Includes items 243, 251 and 252)	1	K5B-526EQ-RS
261	Piston Assembly (Includes items 202 through 205 and item 207)	5	K5B-A513-47
• ---	Motor Gasket Kit (Includes items 202, 207, 209, 226, 243, 244, 248 and 317)	1	26823

DISC BRAKE ASSEMBLY DRAWING

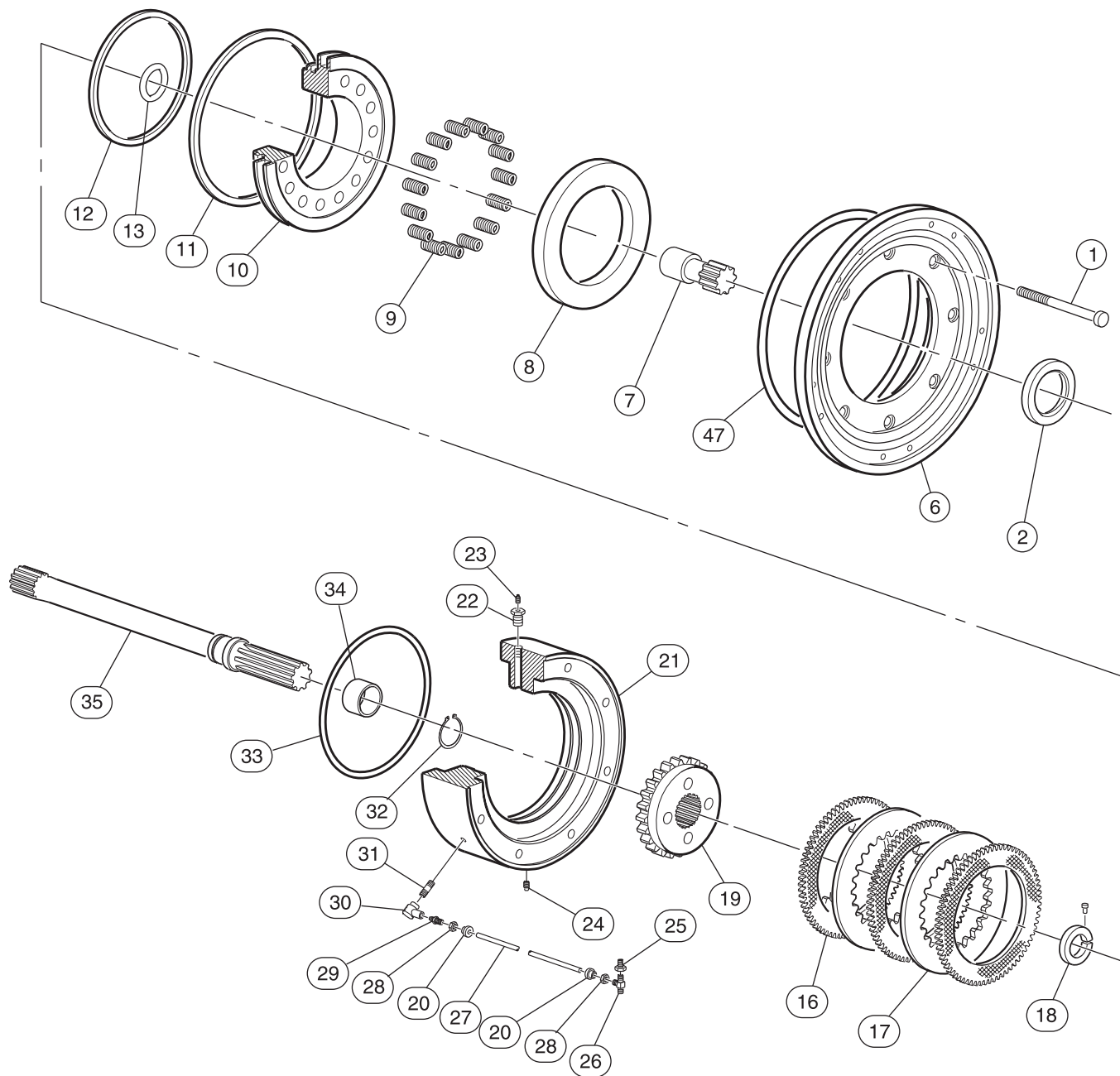

(Dwg. MHP2021)

DISC BRAKE ASSEMBLY PARTS LIST

ITEM NO.	DESCRIPTION OF PART	QTY. TOTAL	PART NUMBER
48	Brake Assembly	1	11366
1	Capscrew (with Disc Brake)	8	51471
2	Oil Seal	1	51873
6	Motor Adapter	1	14227
7	Shaft Extender	1	10594
8	Brake Reaction Plate	1	10597
9	Spring	15	50751
10	Brake Piston	1	15437
• 11	Seal	1	51461
• 12	Seal	1	51462
16	Friction Plate	3	50772
17	Drive Plate	2	50773
18	Collar	1	71039333
19	Splined Hub †	1	10600
20	Fitting, Sleeve	2	55014
21	Brake Housing	1	11322
22	Fitting, Reducer Bushing	1	51803
23	Breather	1	51857
24	Pipe Plug	1	50801
25	Fitting	1	54688
26	Fitting, Elbow (for units with disc brake only)	1	71056972
	Fitting, Tee (for units with auto drum band brake and disc brake only)	1	52181
27	Tubing	1	52520-XX
28	Fitting, Nut	2	55013
29	Vented, Fitting	1	20770
30	Dump Valve	1	50276
31	Fitting, Nipple	1	50859
• 33	'O' Ring	1	51458
34	Spacer	1	18683
35	Drive Shaft †	1	10903
• 47	'O' Ring	1	51458

• Recommended spare for one winch, 2 years of normal operation.

† These parts also come in a cold weather version. For winches with a -C in the model code, adding CH to the end of these part numbers is required to retain winch certification. Example: Order Drive Shaft (item 35) part number 10903 as part number 10903CH.

XX Order in even foot increments; i.e., 52520-03 = 3 feet (1 metre).

DRUM BRAKE ASSEMBLY DRAWING

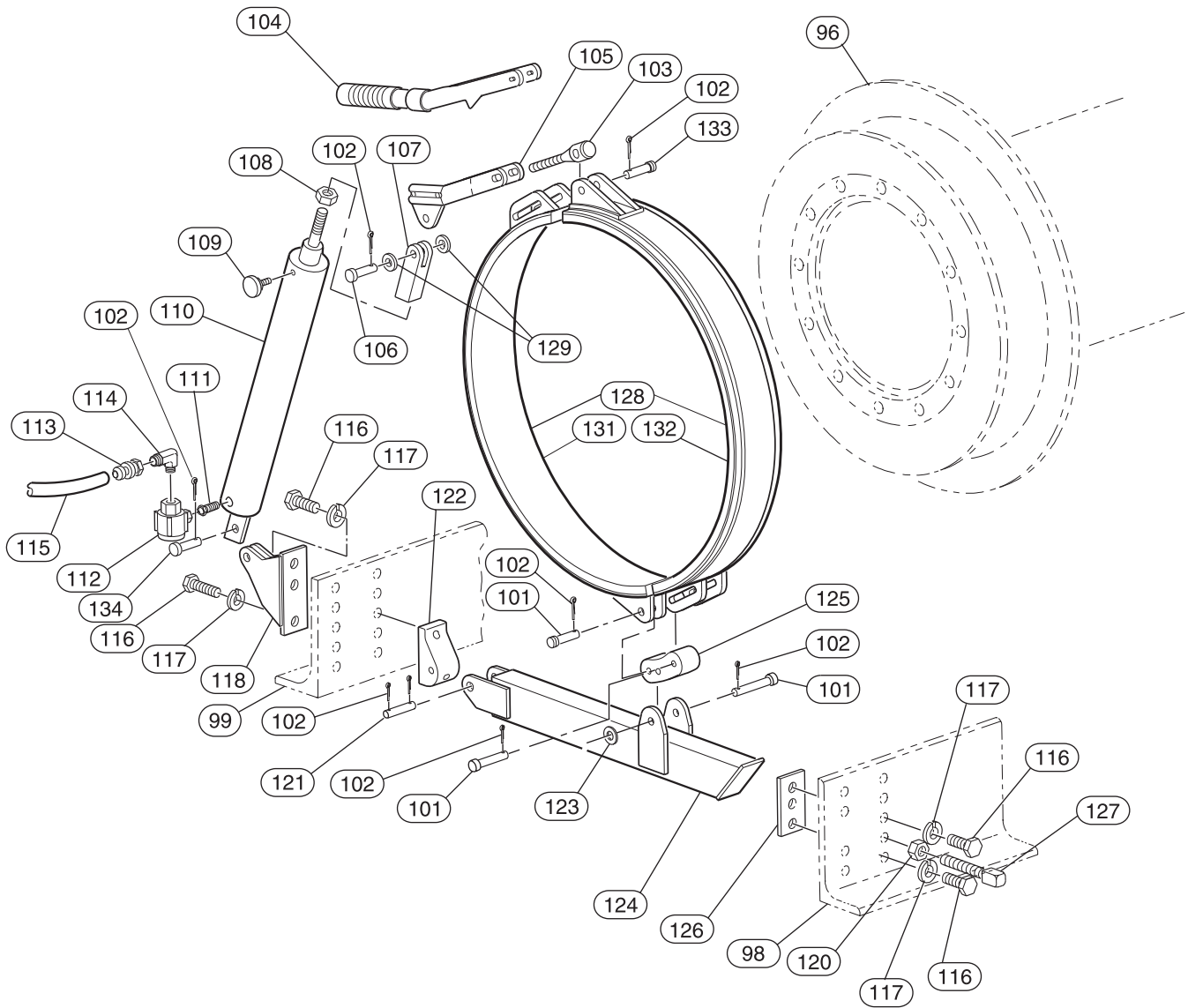

(Dwg. MHP1876)

DRUM BRAKE ASSEMBLY PARTS LIST

ITEM NO.	DESCRIPTION OF PART	QTY. TOTAL	PART NUMBER					
			MANUAL	AUTOMATIC	MANUAL	AUTOMATIC		
			Units prior to 3-21-94		Unit after 3-21-94			
96	Drum with band brake	1	Refer to page 40					
98	Side Rails	1						
99								
100	Brake Assembly - Manual	1	---	10913	---	---		
	Brake Assembly - Automatic		---	---	21342			
101	Pin †	3	4308-S1					
102	Cotter Pin	7	51937					
103	Link Stud †	1	4115					
104	Brake Lever - Manual Brake †	1	4127	---	4127	---		
105	Brake Lever - Automatic Brake	1	---	11349	---	21158		
106	Pin	1		8609		8609		
107	Clevis	1		8586		21282		
108	Nut	1		50152		54570		
109	Breather	1		52384		52384		
110	Cylinder ††	1		8575 (3")		---	6201-1 (4")	
111	Fitting, Bushing	1		52331		52006		
112	Dump Valve	1		51954		51954		
113	Fitting, Hose End	2		52329		51029		
114	Fitting, Elbow	1		51805		54272		
115	Hose (bulk - specify length)	As Req'd		52328-XX		50923-XX		
116	Capscrew	See ()		71128193 (4)		52014 (5)	71128193 (4)	52014 (5)
117	Lockwasher	5		51008				
118	Bracket	1		---		13187	---	23781
120	Nut	See ()	50913 (1)	50913 (2)	50913 (1)	50913 (2)		
121	Pin †	1	10919					
122	Pivot Bracket †	1	10922					
123	Washer	As Req'd	50890					
124	Arm †	1	10921			21182		
125	Connecting Link †	1	10920					
126	Stop Plate	1	10879					
127	Screw, Adjusting	1	71033104	53092	71033104	53092		
• 128	Brake Band †	1 Set	20758					
	Brake Band Lining Kit	1 Kit	20758-BLK					
129	Washer	2	---	52914	---	52914		
131	Brake Band, Rear	1	Order item 128					
132	Brake Band, Front							
133	Pin	1	4308-S					
134	Pin	1	---	**	---	22442		

• Recommended spare for one winch, 2 years of normal operation.

XX Order in even foot increments; i.e., 50923-03 = 3 feet (1 metre).

† These parts also come in a cold weather version. For winches with a -C in the model code, adding CH to the end of these parts is required to retain winch certification. Example: Pivot Bracket (item 122) part number 10922 should be ordered as part number 10922CH.

†† Seal Repair Kit for Cylinder (item 110): old style = 52508; new style = 7132649

Brake Assemblies	Part Number
Manual Brake Assembly, Standard Flange (includes items 101 to 104, 117, 119 to 128 and 133)	10913
Auto Band Brake Assembly, Standard Flange (includes items 101 to 103, 105 to 128 and 133 to 134)	21342

LIVE AIR CONTROL VALVE ASSEMBLY DRAWING AND PARTS LIST

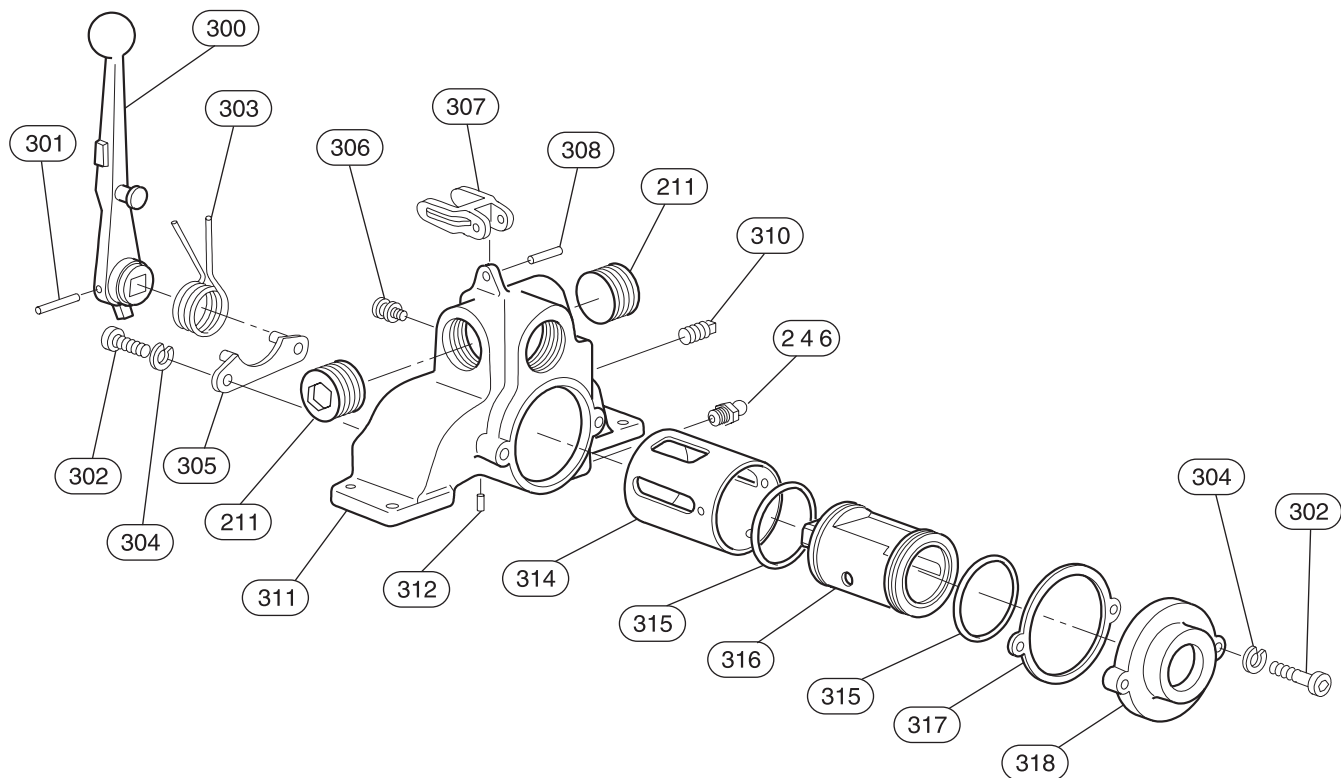

(Dwg. MHP1719)

ITEM NO.	DESCRIPTION OF PART	QTY. TOTAL	PART NUMBER
260	Control Valve Assembly (Includes items 211, 246 and 300 through 318)	1	K5B-REMOTE
211	Pipe Plug	2	71263297
246	Grease Fitting	1	53095
300	Handle	1	K5B-556
301	Roll Pin	1	K5B-1115
302	Capscrew	4	50853
• 303	Spring	1	K5B-412
304	Lockwasher	4	51581
305	Valve Body Retainer	1	K5B-1110A
306	Spring Retaining Stud	1	K5B-553
307	Latch	1	K5B-869A
308	Roll Pin	1	HLK-20
311	Valve Housing (matched set with item 314)	1	K5B-1101
312	Roll Pin	1	25A13C92
314	Valve Bushing (matched set with item 311)	1	K5B-1101
• 315	Seal Ring	2	K5B-606
316	Valve Body	1	K5B-944
• 317	Gasket	1	K5B-275
318	Flange	1	KK5B-276S

• Recommended spare for one winch, 2 years of normal operation.

PILOT AIR CONTROL VALVE (OPTIONAL) ASSEMBLY DRAWING AND PARTS LIST

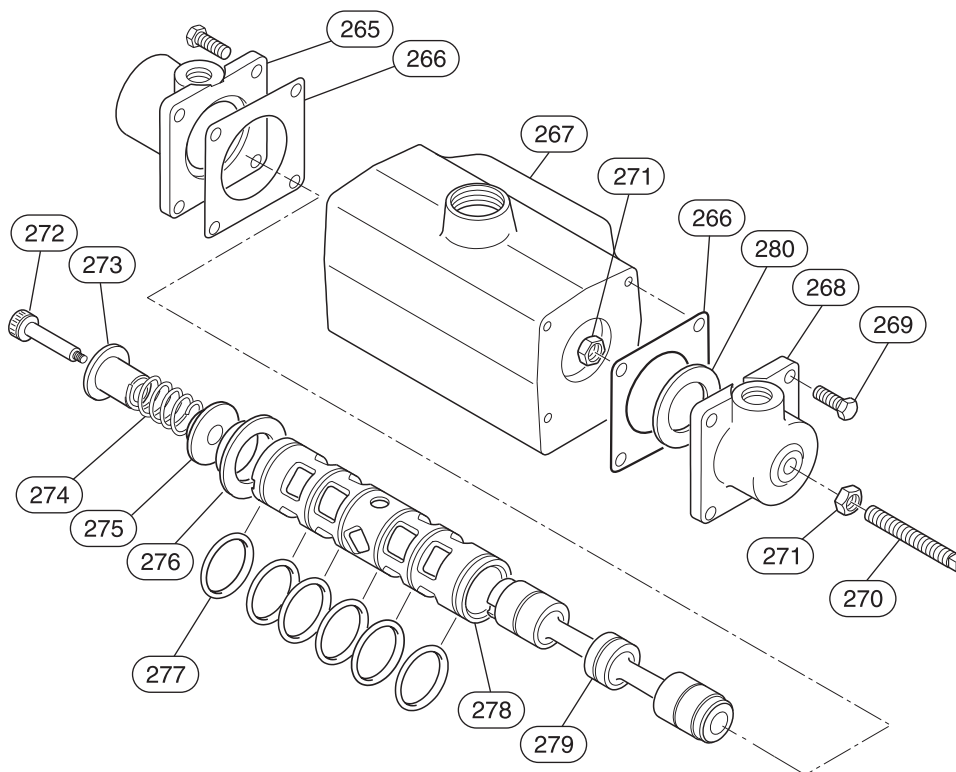

(Dwg. MHP0141)

ITEM NO.	DESCRIPTION OF PART	QTY TOTAL	PART NUMBER
			510 size
355	Valve Assembly (includes items 265 through 280)	1	20993
265	End Cap	1	71136725
266	Gasket	2	71136733
267	Valve Body	1	Not sold separately, order item 355
268	End Cap Assembly (includes items 270 and 271)	1	25591
269	Capscrew	8	71030118
270	Adjusting Screw	1	53545
271	Nut	2	50176
272	Shoulder Screw	1	54710
273	Guide	1	71136741
274	Spring	1	71136758
275	Washer	1	71136774
276	Spacer	1	71136766
277	'O' Ring	6	71136782
278	Valve Sleeve	1	Not sold separately, order item 355
279	Valve Spool	1	
280	Washer	1	71332324

• Recommended spare for one winch, 2 years of normal operation.

SERVICE KIT	PART NUMBER
• Pilot Air Control Valve Service Kit (includes items 266 (qty 2) and 277 (qty 6))	71356406

FULL FLOW REMOTE CONTROL VALVE ASSEMBLY DRAWING AND PARTS LIST

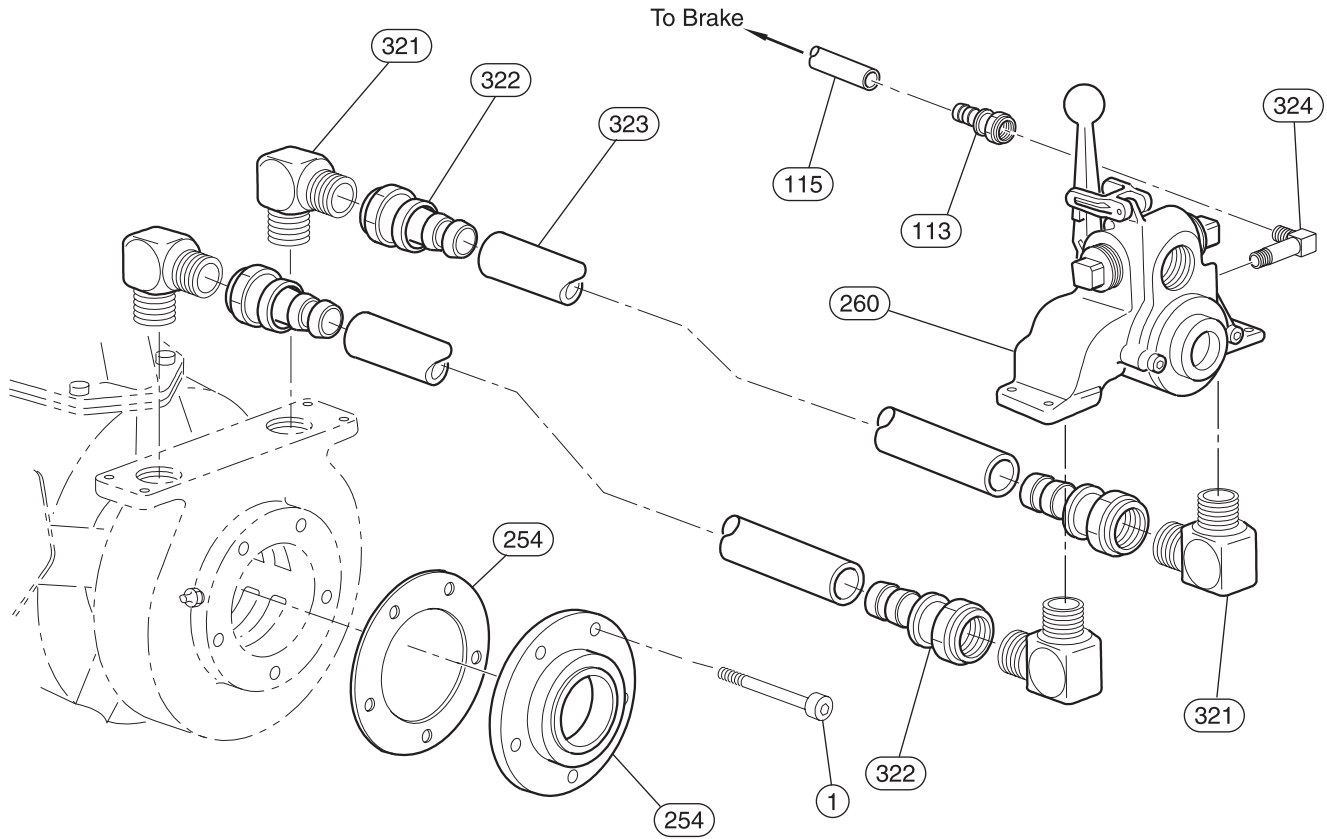

(Dwg. MHP1489)

ITEM NO.	DESCRIPTION OF PART	QTY. TOTAL	PART NUMBER
1	Capscrew	5	51471
113	Hose End	2	51029
115	Hose (bulk)	1	50923-XX
243	Gasket	1	K5B-928
254	Exhaust Cover	1	KK5B-276M
260	Control Valve Assembly	1	K5B-REMOTE
321	Fitting, Elbow	4	54270
322	Hose End	4	54738
323	Hose	2	54737-XX
324	Fitting, Elbow	1	71149975

XX Order in even foot increments; i.e., 50923-03 = 3 feet (1 metre). Maximum length = 20 feet (6 metres). Contact **Ingersoll-Rand** for information on control suitability for lengths greater than 20 feet (6 metres). Metres are for reference only.

PENDANT CONTROL ASSEMBLY (OPTIONAL) DRAWING AND PARTS LIST

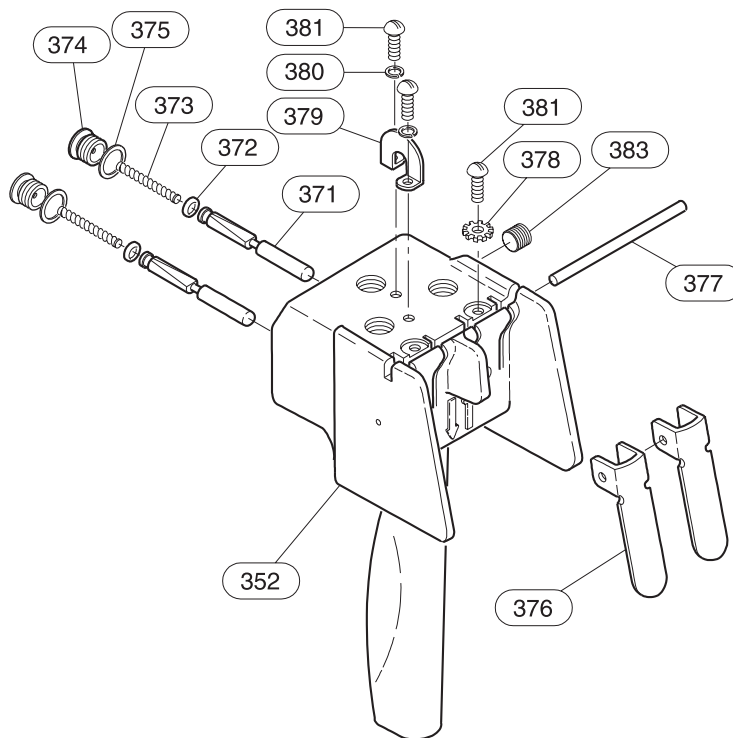

(Dwg. MHP0993)

ITEM NO.	DESCRIPTION OF PART	QTY. TOTAL	PART NUMBER
352	Pendant Assembly (includes items 370–381 and 383) Note: Pendant Handle only available as part of assembly item 352	1	MLK-A269C
371	Throttle Valve	2	MLK-K264B
372	Throttle Valve Face	2	R000BR1C-283
• 373	Spring	2	MKL-51A
374	Throttle Valve Cap	2	MLK-266A
• 375	Valve Cap Gasket	2	MLK-504
376	Lever	2	MLK-273
377	Throttle Lever Pin	1	DLC-120A
378	Pin Lockwasher	2	D02-138
379	Support	1	MLK-450
380	Lockwasher	2	H54U-352-10 *
381	Handle Screw	4	HRE20A-68
382	Fitting, Adapter (not shown on drawing)	3	52092
383	Pipe Plug	1	54247

• Recommended spare for one winch, 2 years of normal operation.

* Sold in quantities of 10 only.

REMOTE PILOT AIR CONTROL (OPTIONAL) ASSEMBLY DRAWINGS AND PARTS LIST

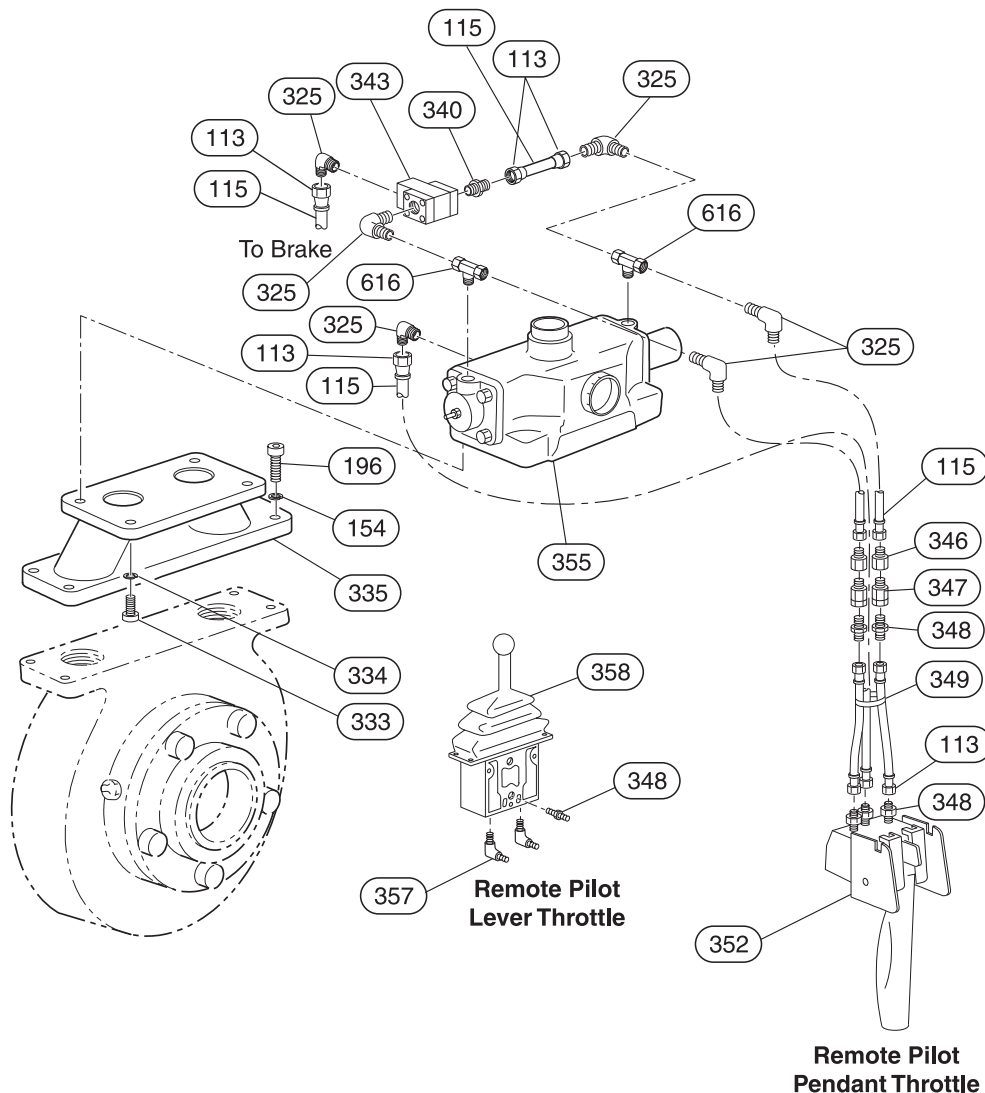

(Dwg. MHP1490)

Remote Pilot Pendant Throttle Control

ITEM NO.	DESCRIPTION OF PART	QTY TOTAL	PART NO.	ITEM NO.	DESCRIPTION OF PART	QTY TOTAL	PART NO.
113	Hose End	As Req'd.	51029	343	Shuttle Valve	1	50277
115	Hose, Bulk	Specify Length	50923-XX	346	Fitting, Adapter	As Req'd.	71048284
154	Lockwasher	4	50200	347	Quick Exhaust Valve Assy *	††	20417
196	Capscrew	4	51780	348	Fitting, Adapter	As Req'd.	71048268
325	Fitting, Elbow	6	52182	349	Hose Tie	As Req'd.	54235
333	Capscrew	4	54681	352	Pendant Assembly (includes item 348)	1	MLK-A269C
334	Lockwasher	4	50893				
335	Manifold	1	13881	355	Valve Assembly	1	20993
340	Fitting, Adapter	2	51814	616	Fitting, Tee	2	K6U-926

Remote Pilot Lever Throttle Valve Associated Components

(Requires item numbers 325, 333-384 plus the following parts. Part numbers and quantities are for a 30 foot (9 metre) assembly.)

357	Fitting, Elbow	2	51281	358	Pilot Lever Throttle	1	71069561
-----	----------------	---	-------	-----	----------------------	---	----------

* Quick Exhaust Valve Assembly (item 347) includes items 325, 327 and 328 in qty for one assembly.

†† Quantity of two Quick Exhaust Valve Assemblies (item 347) required when hose length exceeds 20 feet (6 metres); quantity of four required when hose length exceeds 50 feet (16 metres).

XX Order in equal foot increments; i.e., 50923-03 = 3 feet (1 metre).

DRUM LOCKING PIN (OPTIONAL) ASSEMBLY DRAWING AND PARTS LIST

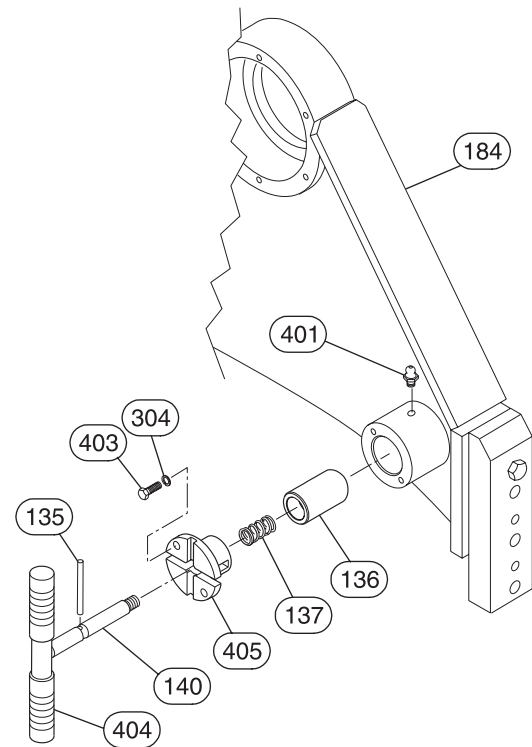
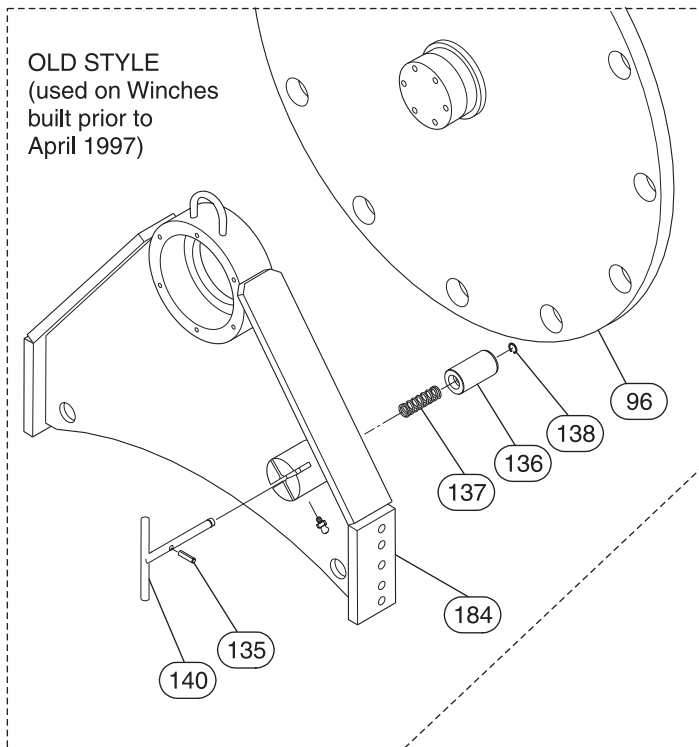

(Dwg. MHP1237)

ITEM NO.	DESCRIPTION OF PART	QTY TOTAL	PART NUMBER	ITEM NO.	DESCRIPTION OF PART	QTY TOTAL	PART NUMBER
96	Old Style Drum with band brake			96	New Style Drum with band brake		
	24 inch with band brake	1	22228-5		24 inch with band brake	1	25607-5
	24 inch without band brake		22228-15		24 inch without band brake		26104-5
	30 inch with band brake		22228-6		30 inch with band brake		25607-6
	30 inch without band brake		22228-16		30 inch without band brake		26104-6
	36 inch with band brake		22228-12		36 inch with band brake		25607-12
	36 inch without band brake		22228-20		36 inch without band brake		26104-10
	42 inch with band brake		Contact factory		42 inch with band brake		25607-11
42 inch without band brake	Contact factory		42 inch without band brake	26104-8			
			55 inch with band brake	contact factory			
			55 inch without band brake	contact factory			

Common Parts:

135	Pin, Old Style	1	71001135	304	Washer	2	51581
	Pin, New Style		71316632		400		Locking Pin Assembly (New Sytle) (includes 135-137, 401-405)
136	Lock Pin, Old Style	1	21072	401		Grease Fitting	1
	Lock Pin, New Style		25858		403	Capscrew	2
137	Spring	1	71316624	404		Grip	2
	138	Retainer Ring	1		54370	405	Gland Cap
140		Pull Rod, Old Style	1	21073			
	Pull Rod, New Style	25861					
184	Outboard Upright						
	Old style, standard and tall flange	1	*				
	New style, standard and tall flange		26103				
	Guideline		25761				

GUIDELINE REDUCTION GEAR ASSEMBLY DRAWING

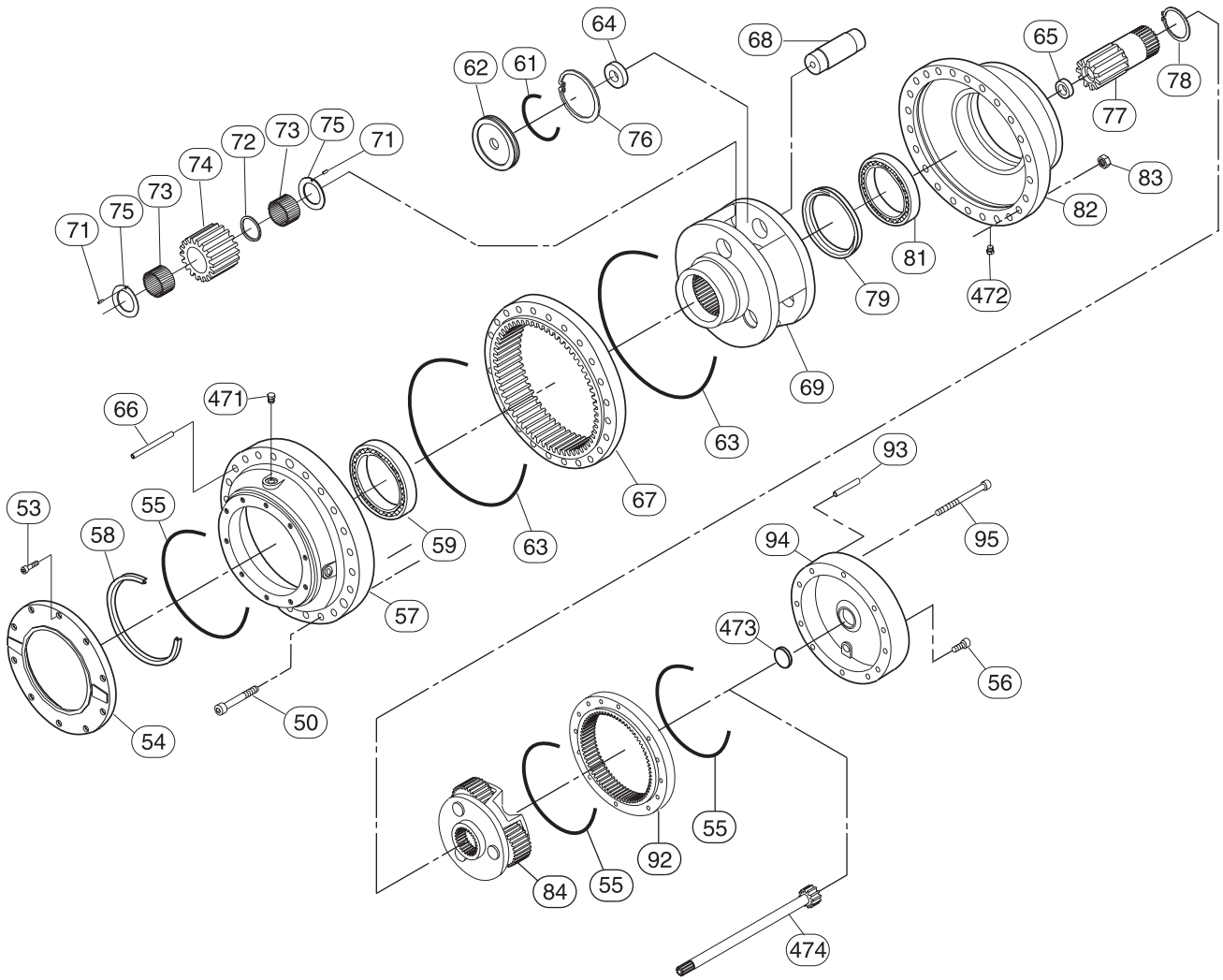

(Dwg. MHP1708)

GUIDELINE REDUCTION GEAR ASSEMBLY PARTS LIST

ITEM NO.	DESCRIPTION OF PART	QTY TOTAL	PART NUMBER	ITEM NO.	DESCRIPTION OF PART	QTY TOTAL	PART NUMBER
49	Reduction Gear Assy	1	27012	73	Bearing Roller †	204	†
50	Capscrew	18	71316509	74	Planetary Gear †	3	†
53	Capscrew	10	154-2520	75	Thrust Bearing †	6	†
54	Oil Seal Support	1	71138937	76	Retainer Ring †	1	†
55	'O' Ring	3	71139059	77	Sun Gear	1	154-1648
56	Plug	2	71068571	78	Retainer Ring	1	71068597
57	Output Housing	1	71138929	79	Bearing Spacer	1	71139042
58	Oil Seal	1	154B3488	81	Bearing, Ball	1	71138960
59	Bearing, Ball	1	71138979	82	Input Housing	1	71138911
61	'O' Ring †	1	†	83	Nut	18	71112288
62	Thrust Plate †	1	†	84	Planetary Assembly	1	154-1914
63	'O' Ring	2	154B3626	85	Ring Gear	1	71068514
64	Thrust Plate †	1	†	93	Pin	4	71068464
65	Thrust Bearing	1	154B2806	94	End Cover	1	154-1798
66	Pin	3	71139026	95	Capscrew	8	154-2528
67	Ring Gear	1	71138887	471	Plug	4	154-2710
68	Shaft, Planet Gear †	3	†	472	Magnetic Trap	4	154-2713
69	Planetary Gear Assy †	1	†	473	Thrust Plate	1	154-1711
71	Spring Pin †	6	†	474	Shaft, Pinion	1	
72	Spacer †	3	†				

* Reduction Gear Assembly (49) consists of all items listed above.

† Order Reduction Gear Assembly (item 49).

GUIDELINE CONTROL VALVE ASSEMBLY DRAWING

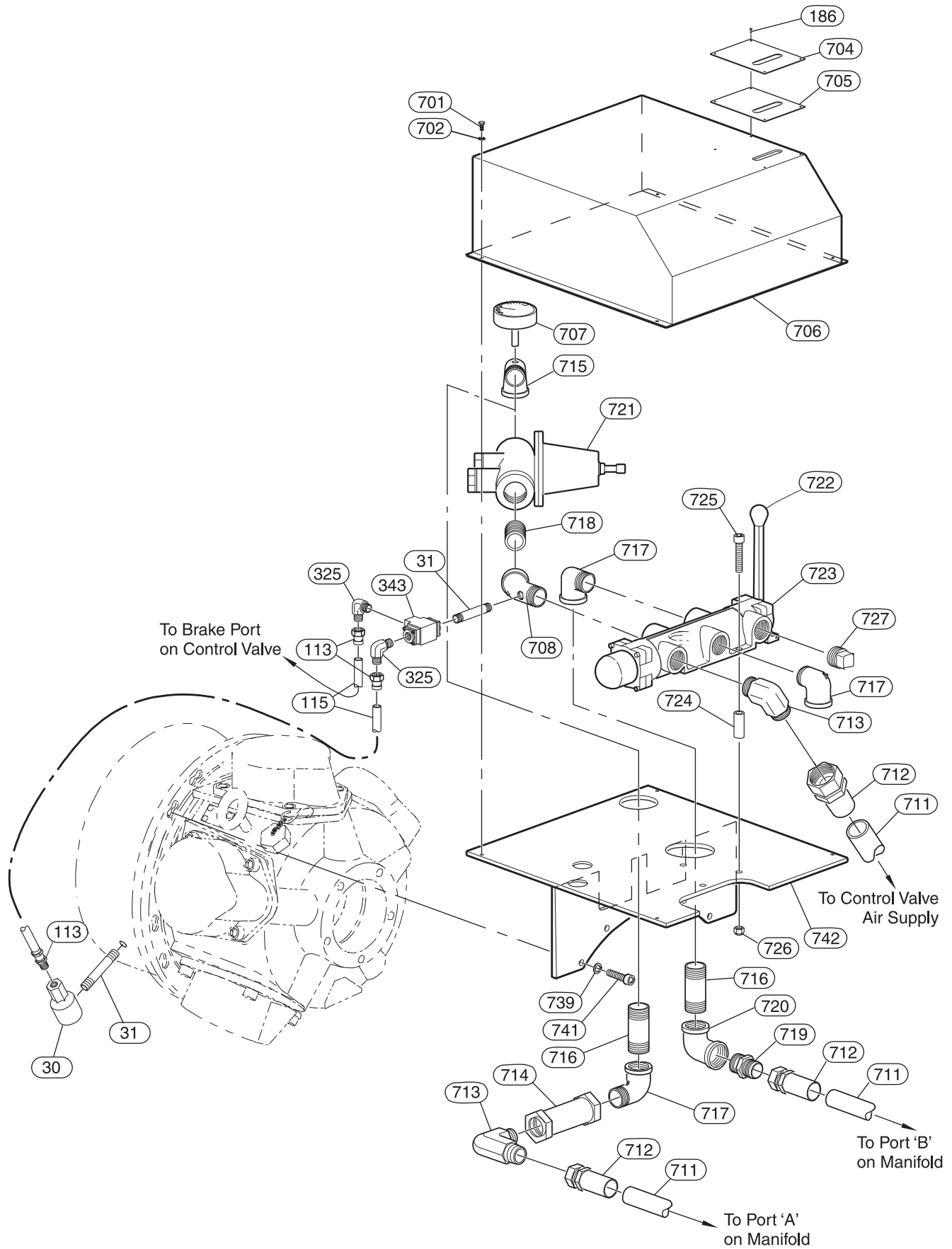

(Dwg. MHP1329)

GUIDELINE CONTROL VALVE ASSEMBLY PARTS LIST

ITEM NO.	DESCRIPTION OF PART	QTY TOTAL	PART NUMBER	ITEM NO.	DESCRIPTION OF PART	QTY TOTAL	PART NUMBER
30	Dump Valve	1	50276	714	Check Valve	1	71320916
31	Fitting, Nipple	2	50859	715	Fitting, Elbow	1	26057
113	Fitting, Hose	4	51029	716	Pipe Nipple	2	71320907
115	Hose (bulk)	As Req'd.	50923-XX	717	Fitting, Elbow	3	54243
186	Rivet	6	50915	718	Fitting, Nipple	1	50933
325	Fitting, Elbow	2	52182	719	Fitting, Connector	1	71308258
343	Valve, Shuttle	1	50277	720	Fitting, Elbow	1	50928
701	Capscrew	4	71127054	721	Regulator	1	71316996
702	Washer	4	71320964	722	Ball, Handle	1	71138051
704	Label	1	25880	723	5-Way Valve	1	71316434
705	Gasket	1	25975	724	Spacer	3	14998-8B
706	Cover	1	25884	725	Capscrew	3	71319073
707	Gauge, Pressure	1	71272686	726	Nut	3	71320931
708	Fitting, Elbow	1	26056	727	Plug	1	52304
711	Hose (bulk)	As Req'd.	51003-XX	739	Washer	4	71320956
712	Hose End	6	51002	741	Capscrew	4	71320949
713	Fitting, Elbow	2	51001	742	Bracket, Control	1	25873

XX Order in even foot increments: 50923-03 = 3 feet (1 metre).

DRUM GUARD ASSEMBLY DRAWING AND PARTS LIST

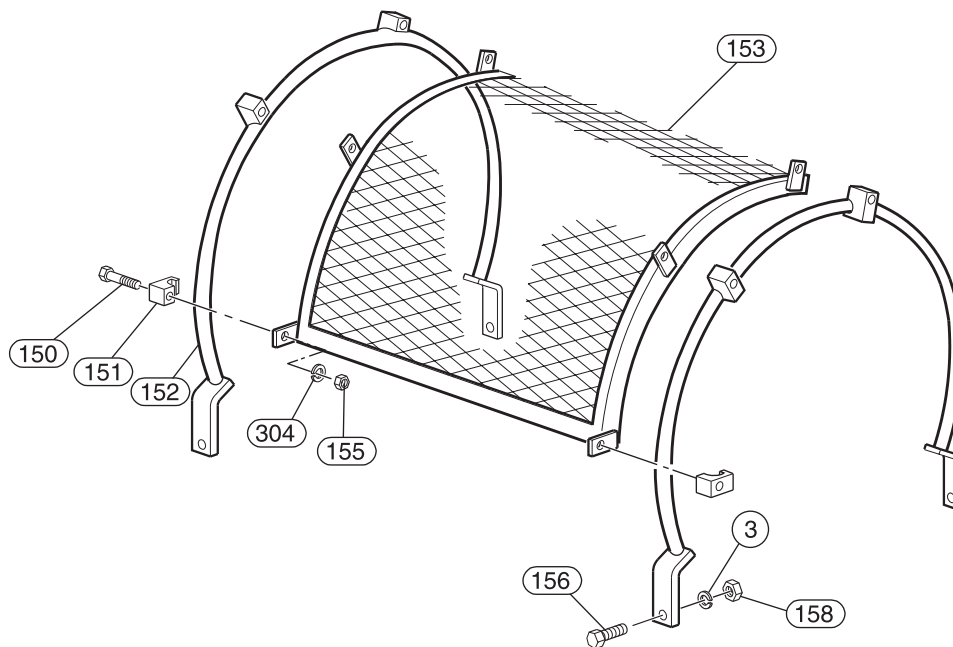

(Dwg. MHP0205)

ITEM NO.	DESCRIPTION OF PART	QTY TOTAL	PART NUMBER	
			Standard Flange	Tall Flange
	Drum Guard Assembly (includes items 3 and 150–158)			
*	24 inch long drum	1	11994-5	10928-5
	30 inch long drum		11994-6	10928-6
	36 inch long drum		11994-8	10928-11
	42 inch long drum		---	10928-12
	55 inch long drum		---	contact factory
3	Lockwasher	4	50181	
150	Capscrew	6	51579	
151	Clamp	6	10399	
152	Support	2	10936	10929
153	Drum Guard (24 inch long drum)	1	11993-5	10930-5
	Drum Guard (30 inch long drum)		11993-6	10930-6
	Drum Guard (36 inch long drum)		11993-8	10930-11
	Drum Guard (42 inch long drum)		---	10930-12
	Drum Guard (55 inch long drum)		---	contact factory
155	Nut	6	51440	
156	Capscrew	4	50973	
158	Nut	4	51750	
304	Lockwasher	6	51581	

* Assembly includes items 3, 150 to 158 and 304.

EMERGENCY STOP AND OVERLOAD ASSEMBLY DRAWING

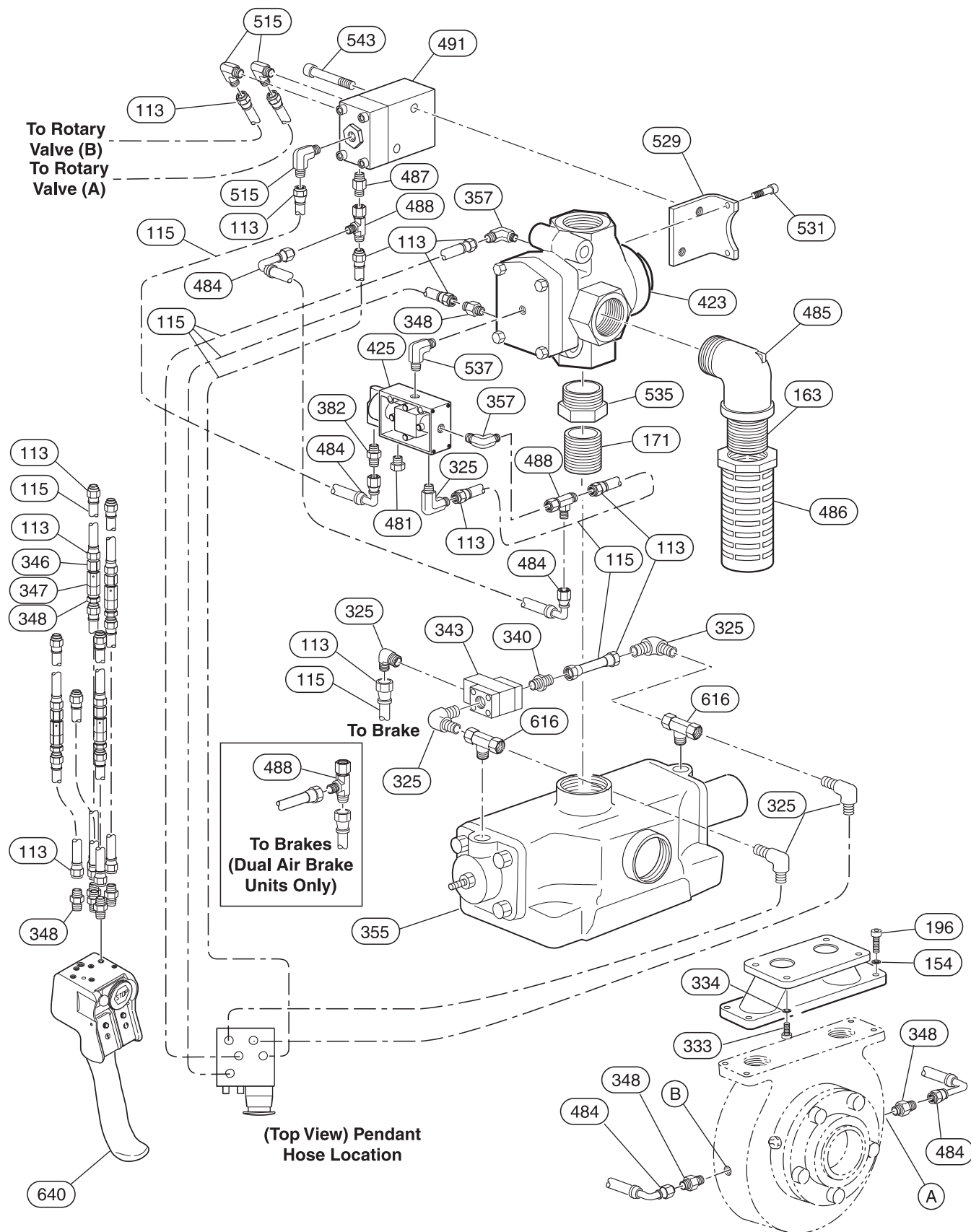

(Dwg. MHP1488)

EMERGENCY STOP AND OVERLOAD ASSEMBLY PARTS LIST

ITEM NO.	DESCRIPTION OF PART	QTY TOTAL	PART NUMBER	ITEM NO.	DESCRIPTION OF PART	QTY TOTAL	PART NUMBER
113	Hose End	As Req'd	51029	425	Shuttle Valve	1	71269039
115	Hose (bulk)		50923-XX	481	Breather	1	50595
154	Lockwasher	4	50200	484	Fitting, Elbow	5	52179
163	Fitting, Nipple	1	71057483	485	Fitting, Pipe	1	71273676
171	Fitting, Nipple	1	51704	486	Muffler	1	52472
196	Capscrew	4	51780	487	Fitting, Connector	1	71078158
325	Fitting, Elbow	6	52182	488	Fitting, Swivel-Tee **	2 (3)	71067789
333	Capscrew	4	54681	491	Valve, Delta P	1	36360002
334	Lockwasher	4	50893	515	Fitting, Elbow	3	71327316
340	Fitting, Connector	1	51814	529	Bracket	1	26148
343	Shuttle Valve	1	50277	531	Capscrew	2	71327324
346	Fitting, Connector	4	71048284	535	Pipe Bushing	1	51706
347	Valve, Exhaust *	As Req'd	20417	537	Fitting, Elbow	1	54273
348	Fitting, Connector	13	71048268	543	Capscrew	2	54240
357	Fitting, Elbow	2	51281	616	Fitting, Tee	2	K6U-926
382	Fitting, Connector	1	52092	640	Pendant Assembly	1	PHS2E-U
423	Valve, Shut-off	1	25541				

* Exhaust valves must be installed at 20 foot (6 metre) intervals. Item 347 includes items 113 (qty. 2), 346 and 348.

** Fitting, Swivel-Tee, item 488 quantity total = 2 for single brake/3 for dual brake applications.

XX Order in even foot increments; i.e., 50923-03 = 3 feet (1 metre).

EMERGENCY STOP VALVE AND OVERLOAD ASSEMBLY DRAWING AND PARTS LIST

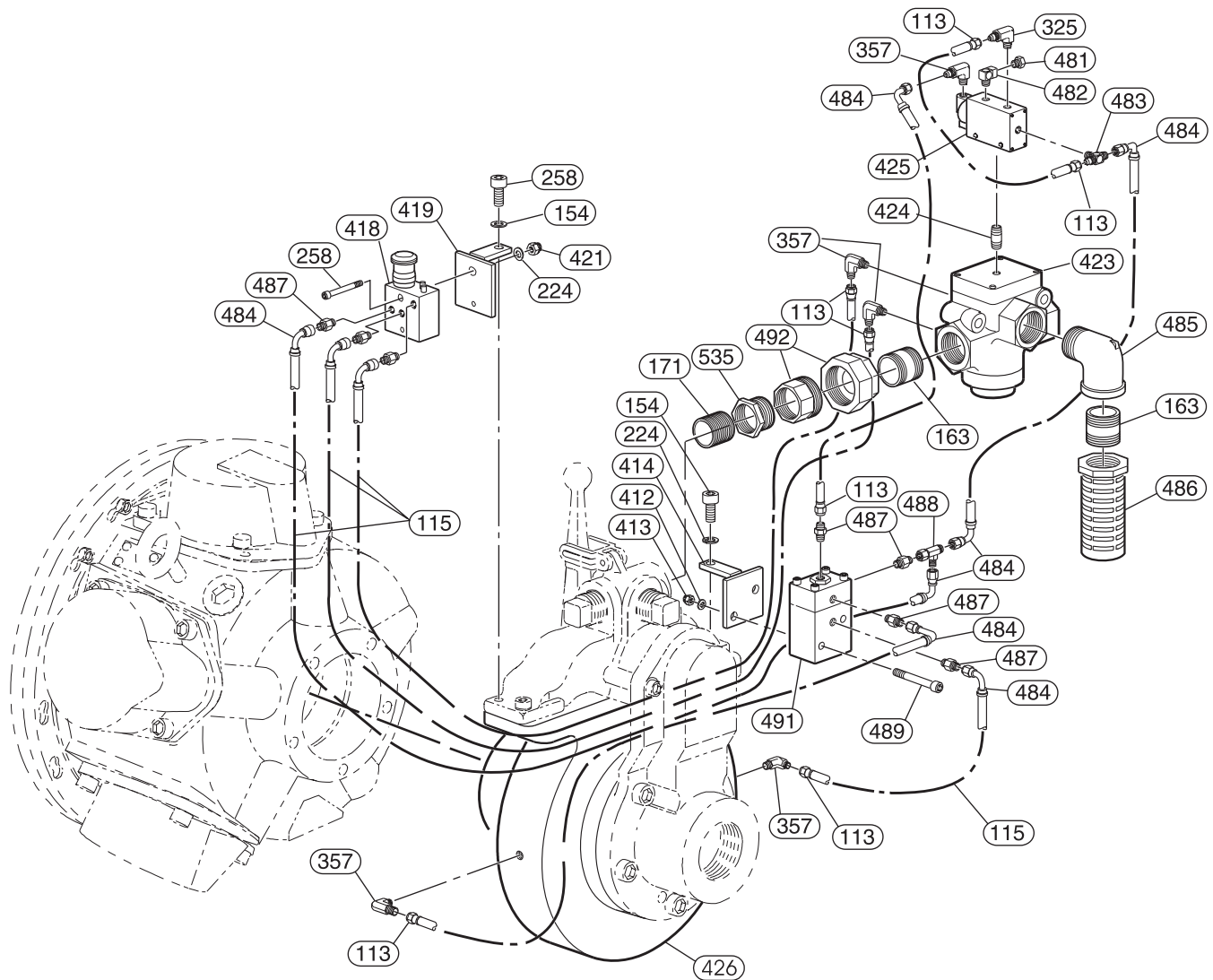

(Dwg. MHP1341)

ITEM NO.	DESCRIPTION OF PART	QTY TOTAL	PART NUMBER	ITEM NO.	DESCRIPTION OF PART	QTY TOTAL	PART NUMBER
113	Hose End	7	51029	423	Valve, Shut-off	1	25541
115	Hose (bulk)	As Req'd	50923-XX	424	Fitting, Nipple	1	52191
154	Washer	4	50200	425	Pilot Valve	1	71269039
163	Fitting, Nipple	2	71057483	426	Rotary Housing	1	24492
171	Fitting, Nipple	1	51704	481	Breather	1	50595
224	Washer	4	51676	482	Fitting, Elbow	1	71034714
257	Capscrew	4	51766	483	Fitting, Tee	1	54081
258	Capscrew	4	51079	484	Fitting, Elbow	9	52179
325	Fitting, Elbow	1	52182	485	Fitting, Pipe	1	71273676
357	Fitting, Elbow	5	51281	486	Muffler	1	52472
412	Washer	2	50177	487	Fitting, Connector	7	71078158
413	Nut	2	50170	488	Fitting, Swivel-Tee	1	71067789
414	Bracket, Overload	1	24491	489	Capscrew	2	50848
418	Emergency Stop Valve	1	35790066	491	Valve, Delta P	1	36360002
419	Bracket, E-Stop	1	24490	492	Fitting, Pipe	1	71149355
421	Nut	2	53541	535	Pipe Bushing	1	51706

XX Order in even foot increments: 50923-03 = 3 feet (1 metre).

REMOTE PENDANT WITH EMERGENCY STOP ASSEMBLY AND PARTS LIST

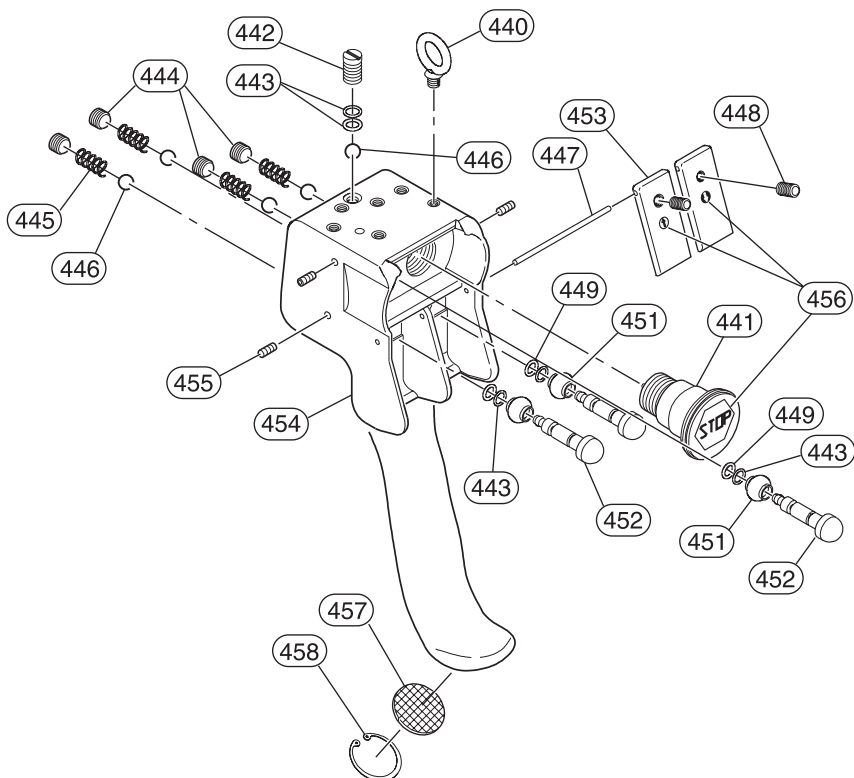

(Dwg. MHP1709)

ITEM NO.	DESCRIPTION OF PART	QTY TOTAL	PART NUMBER	ITEM NO.	DESCRIPTION OF PART	QTY TOTAL	PART NUMBER
640	Pendant Assembly	1	PHS2E-U	• 449	'O' Ring	3	58235329
440	Lifting Eye	1	64222332	451	Protector	3	95790107
441	Emergency Stop Valve	1	95790108	452	Valve	3	95790104
442	Plug	3	95790106	453	Lever	2	95790122
• 443	'O' Ring	5	58209229	454	Pendant Handle	1	order item 640
444	Plug	4	65107741	455	Setscrew	3	42008307
445	Spring	4	69128541	456	Label Kit	1	95790111
446	Ball	5	69401625	457	Exhaust Washer	1	67600303
447	Pin	1	95790040	458	Retainer Ring	1	47713030
448	Setscrew	2	42006207				

• Recommended spare for one winch, 2 years of normal operation.

LIMIT SWITCH ASSEMBLY DRAWING

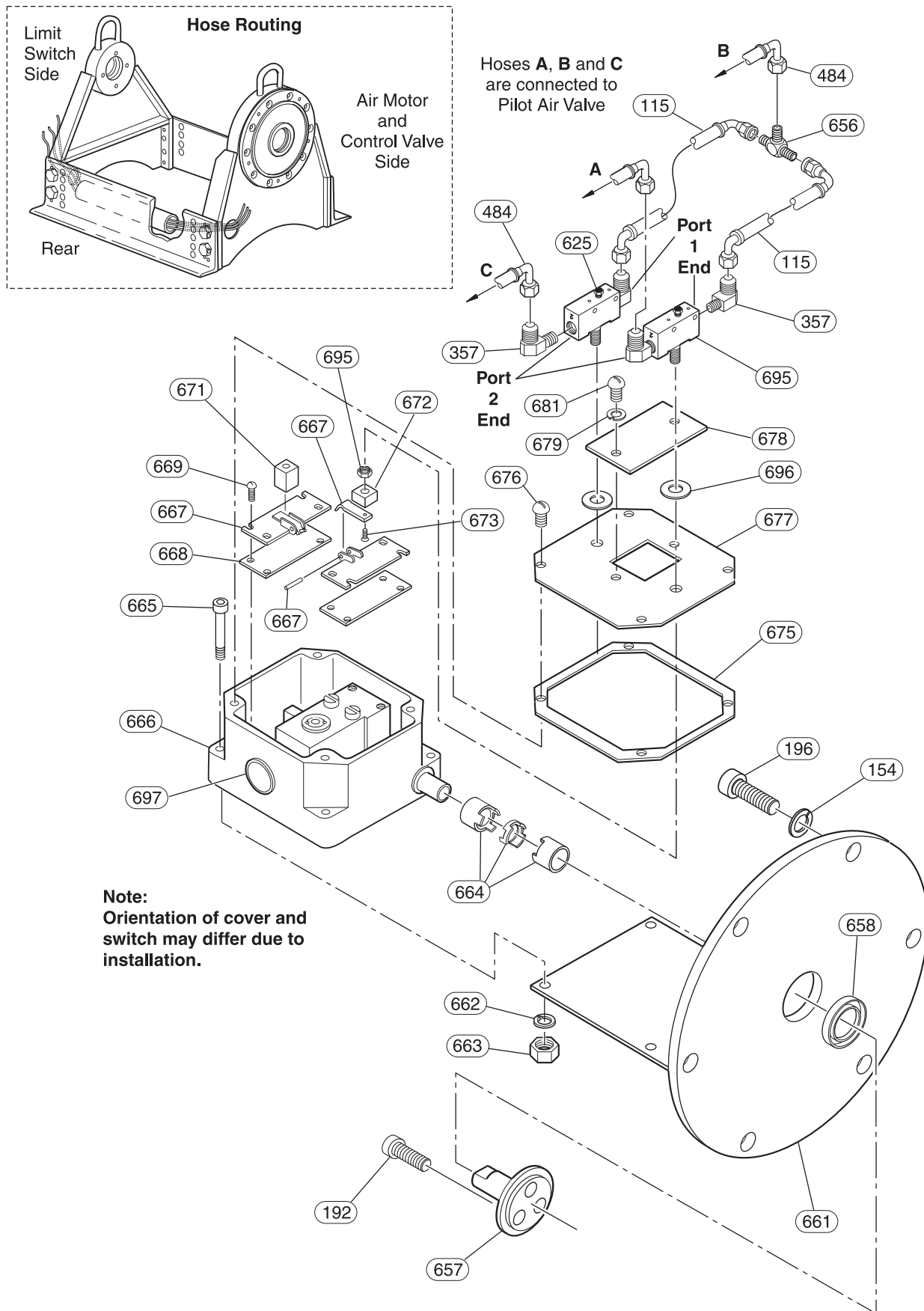

(Dwg. MHP1866)

LIMIT SWITCH ASSEMBLY PARTS LIST

ITEM NO.	DESCRIPTION OF PART	QTY TOTAL	PART NUMBER
115	Hose	As Req'd	50923-XX
154	Lockwasher	6	50200
192	Capscrew	3	51086
196	Capscrew	6	51780
357	Fitting, Elbow	4	51281
484	Fitting, Elbow	7	52179
625	Breather	2	51559
656	Fitting, Tee	1	53940
657	Retainer (replaces Retainer, item 191, on standard winch)	1	11485
658	Seal	1	52382
661	Bracket, Limit Switch	1	11484
662	Lockwasher	4	52909
663	Nut	4	54142
664	Coupling Assembly	1	52381
665	Capscrew	4	54493
666	Limit Switch Assembly (includes items 667–681)	1	27309-1
667	Lever Assembly	2	Order item 666
668	Plate	2	2688
669	Capscrew	8	71055966
671	Block, Tall	1	27312
672	Block, Short	1	27311
673	Capscrew	2	53869
675	Gasket	1	Order item 666
676	Capscrew	4	
677	Cover Plate	1	
678	Access Plate	1	3394-B
679	Lockwasher	2	51801
681	Capscrew	2	71007009
695	Nut	2	71356430
696	Washer	2	50182
697	Plug	1	71027494

XX Order in equal foot increments; i.e., 50923-03 = 3 feet (1 metre).

PILOT AIR VALVE PLUMBING ASSEMBLY DRAWING

Note: Hoses A, B and C are connected to Limit Switch

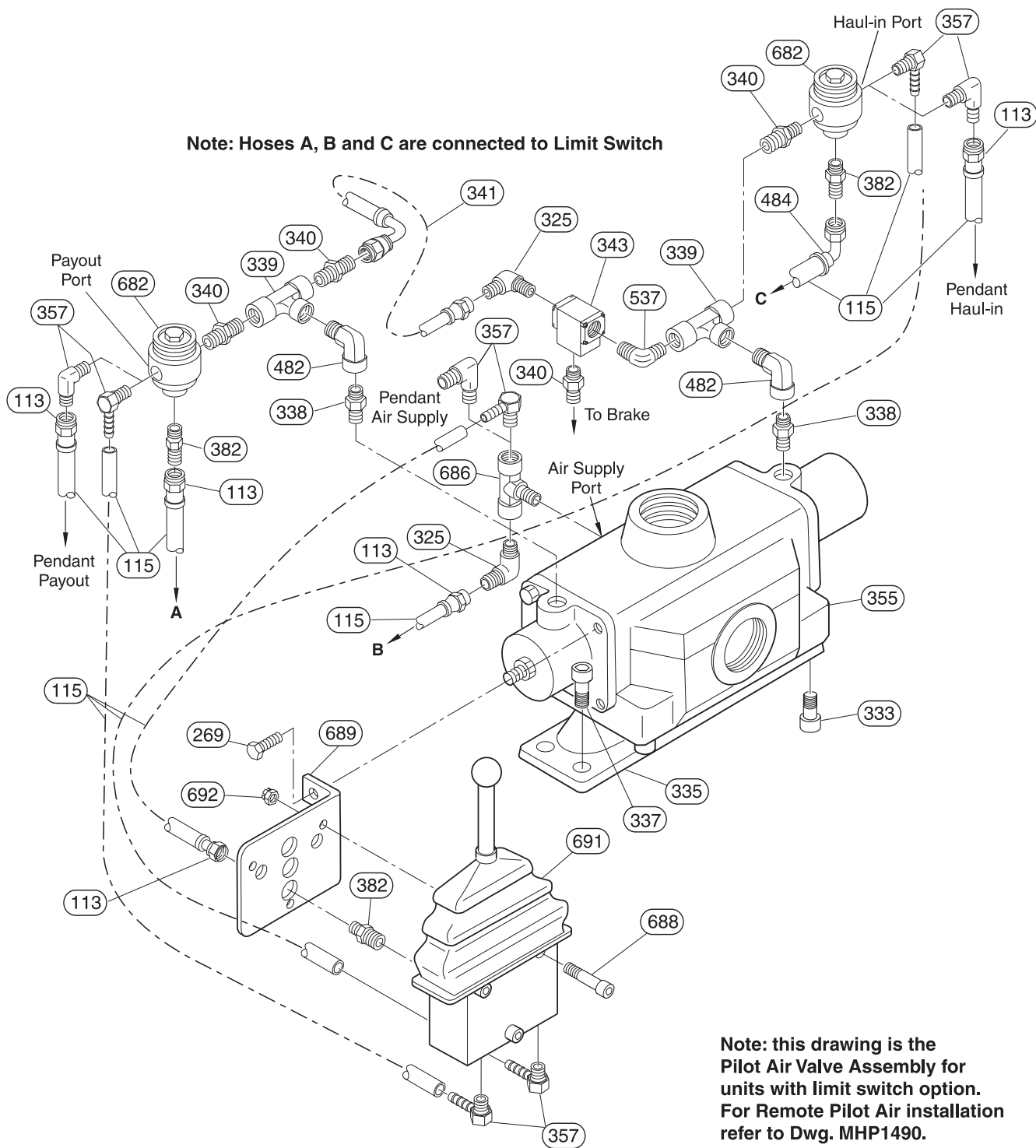

Note: this drawing is the Pilot Air Valve Assembly for units with limit switch option. For Remote Pilot Air installation refer to Dwg. MHP1490.

(Dwg. MHP1716)

PILOT AIR VALVE PLUMBING ASSEMBLY PARTS LIST

ITEM NO.	DESCRIPTION OF PART	QTY TOTAL	PART NUMBER
113	Fitting, Hose End	5	51029
115	Hose	As Req'd	50923-XX
269	Capscrew	2	71030118
325	Fitting, Elbow	2	52182
333	Capscrew	4	54681
335	Manifold, Adapter	1	13881
337	Capscrew	4	50829
338	Fitting, Connector	2	54274
339	Fitting, Tee	2	54678
340	Fitting, Connector	2	51814
341	Hose Assembly	1	17073-6
343	Valve	1	50277
355	Valve Assembly	1	20993
357	Fitting, Elbow (Pendant Control)	3	51281
	Fitting, Barbed (Pilot Control)	5	71062889
382	Fitting, Connector	3	52092
482	Fitting, Elbow	2	71034714
484	Fitting, Elbow	1	52179
537	Fitting, Elbow	1	54273
682	Valve	2	51756
686	Fitting, Tee	1	54977
688	Capscrew	3	71053763
689	Bracket	1	20231
691	Throttle Valve Assembly	1	71149389
692	Nut	3	54171

XX Order in equal foot increments; i.e., 50923-03 = 3 feet (1 metre).

TENSIONING MANIFOLD ASSEMBLY DRAWING

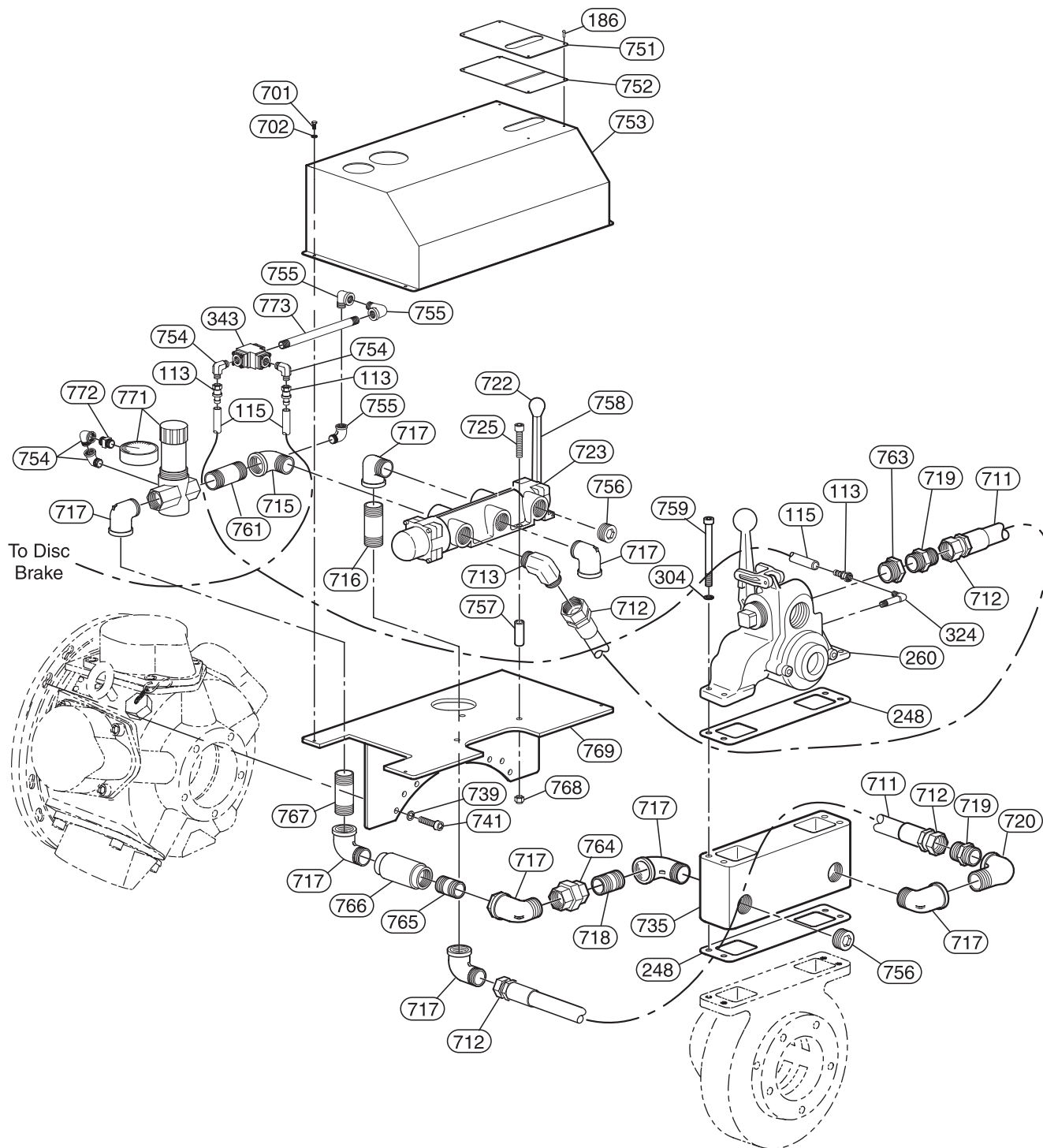

(Dwg. MHP1870)

TENSIONING MANIFOLD ASSEMBLY PARTS LIST

ITEM NO.	DESCRIPTION OF PART	QTY TOTAL	PART NUMBER
113	Fitting, Hose End	3	51029
115	Hose	As Req'd.	50923-XX
186	Rivet	6	50915
248	Gasket	2	K5B-547
260	Control Valve Assembly	1	K5B-REMOTE
304	Lockwasher	4	51581
324	Fitting, Elbow	1	71149975
343	Shuttle Valve	1	50277
701	Capscrew	4	71127054
702	Washer	4	71320964
711	Hose	As Req'd.	51003-XX
712	Fitting, Hose End	4	51002
713	Fitting, Elbow	1	51001
715	Fitting, Elbow	1	26057
716	Fitting, Nipple	1	71320907
717	Fitting, Elbow	8	54243
718	Fitting, Nipple	2	50933
719	Fitting, Nipple	2	71308258
720	Fitting, Elbow	1	50928
722	Handle, Ball	1	71138051
723	Valve	1	71316434
725	Capscrew	3	71319073
735	Manifold, Control Valve	1	25874
739	Washer	4	71320956
741	Capscrew	4	71320949
751	Label, Tensioning Manifold	1	26217
752	Gasket	1	26216
753	Cover	1	26215
754	Fitting, Elbow	2	54869
755	Fitting, Elbow	5	52803
756	Plug	2	71069017
757	Spacer	3	14998-8B
758	Handle	1	26149
759	Capscrew	4	71328199
761	Fitting, Nipple	1	51034
763	Fitting, Bushing	1	51705
764	Fitting, Union	1	71328330
765	Fitting, Nipple	1	71328314
766	Check Valve	1	71320915
767	Fitting, Nipple	1	71328249
768	Nut	3	71069132
769	Bracket	1	26095
771	Regulator and Gauge *	1	71325047
772	Fitting, Connector	1	54943
773	Fitting, Tube Extension	1	71325591

XX Order in equal foot increments; i.e., 50923-03 = 3 feet (1 metre).

* Items not sold separately.

AIR PREPARATION ASSEMBLY DRAWING AND PARTS LIST

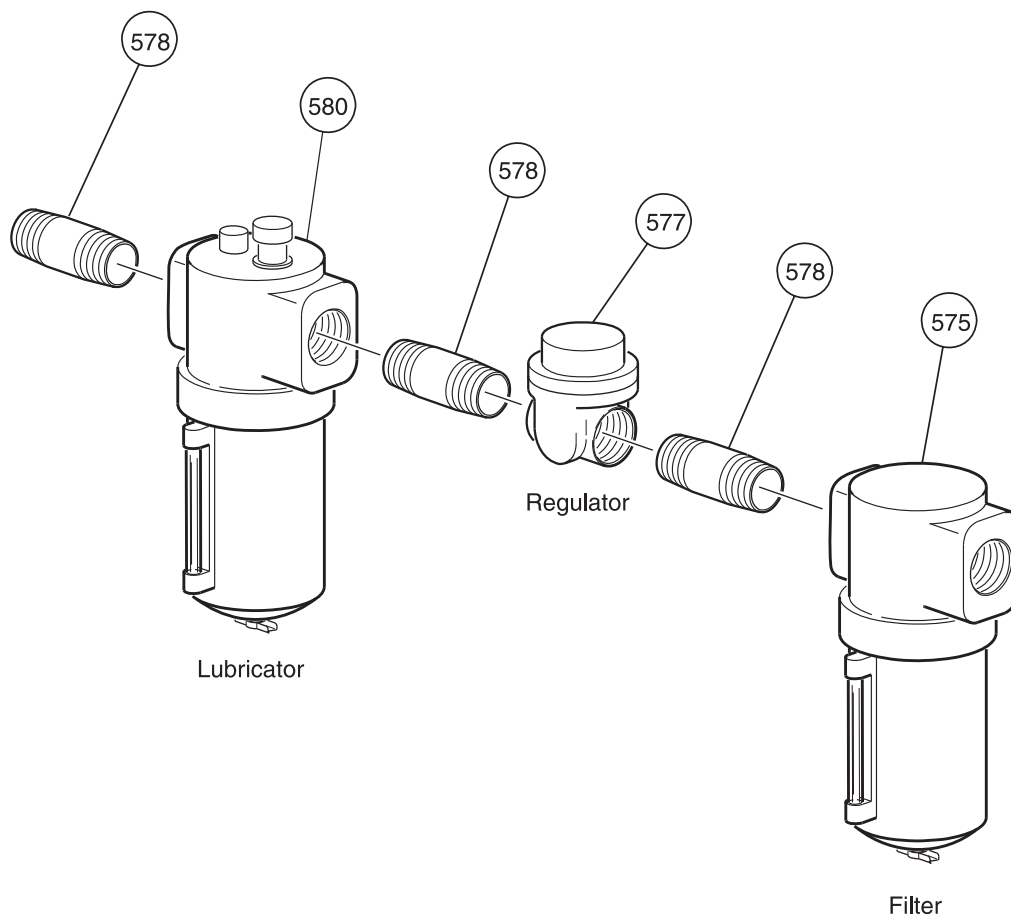

(Dwg. MHP0223)

Note: Actual components may not appear identical to items shown in drawing.

ITEM NO.	DESCRIPTION OF PART	QTY TOTAL	PART NUMBER
575	Filter	1	F35-0B-C28
577	Regulator	1	R40-0B-G00
578	Pipe Nipple (1-1/2 NPT*)	As Required	---
580	Lubricator	1	L40-0B-G00
**	Liquidator	1	8834-W1-000
**	Pipeline Strainer	1	K4U-A267AT

Air preparation components for 1-1/2 inch NPT system.

* Length as required for installation.

** Not shown on drawing.

KITS AND ACCESSORIES

DESCRIPTION OF ACCESSORY	ACCESSORY PART NUMBER
Lubricant	LUBRI-LINK-GREEN
Disc Brake Kit (adds brake to winch) (Includes items 1, 7-12, 16-31, 33, 34 and 36-38)	FA5-DBRK
Thermoplastic Powder (2 ounces) *	71308902
Propane Torch *	71308886
Heat Gun *	71308894

* For Guideline and Podline Unit touch-up (thermoplastic coating).

LABELS AND TAGS

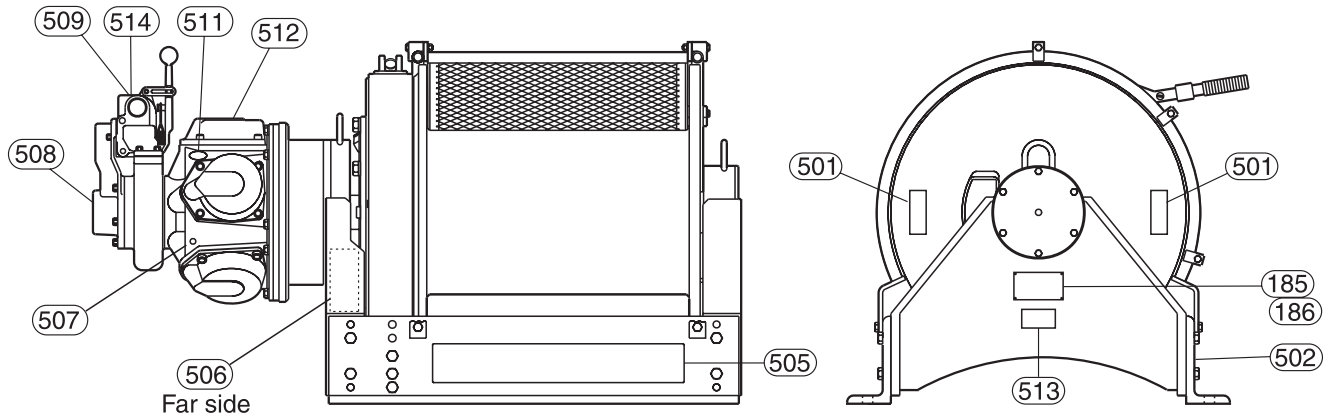

(Dwg. MHP1455)

ITEM NO.	DESCRIPTION OF PART	QTY TOTAL	PART NUMBER	ITEM NO.	DESCRIPTION OF PART	QTY TOTAL	PART NUMBER
500	Label and Tag Kit	1	22261-5S	507	Oil Level Label	1	71043616
	Label and Tag Kit - E		24305-5S	508	Exhaust Label	1	71042196
185	Nameplate	1	71106967-R	509	Air Supply Label	1	71046395
186	Drive Screw	4	50915	511	Check Oil Level Label	1	71107148
501	Winding Label	2	71109516	512	Warning Label (Non-E)	1	71107130
	Winding Label - E		96180103	513	Label General - E only	1	71153464
502	Logo Label (23 in. long)	1	71109102	514	Control Valve Operation - E	1	96180102
505	Product Label	1	71119508				
506	Warning Label	1	71060529				
	Warning Label - E		96180100				

COMMON PARTS LIST

ITEM NO.	DESCRIPTION OF PART	PART NUMBER	ITEM NO.	DESCRIPTION OF PART	PART NUMBER
1	Capscrew, SOCH, G8, 1/2NC x 5	51471	155	Nut, HH, ZP, 3/8 NC	50198
3	Lockwasher, ZP, 1/2	50181	155	Nut, HH, SST, 3/8NC	51440
4	Capscrew, SOCH, G8, 1/2NC x 1-3/4	52379	156	Capscrew, HH, ZP, G5, 1/2NC x 1-1/4	50973
5	‘O’ Ring, Parker #2-280	51459	158	Nut, Lock, ZP, 1/2NC	51750
13	‘O’ Ring, Parker #2-320	54462	160	Pipe Nipple 1-1/4 NPT x 5-1/4	71057491
22	Fitting, Reducer, 1/2 x 1/8 NPT	51803	161	Pipe Elbow, Reducer, 1.5 x 1.25 NPT	71033450
24	Pipe Plug, 1/2 NPT	50801	162	Hose Clamp, Max. OD 2.5	71033500
25	Fitting, Reducer, 1/8 x 1/2 NPT Galv.	54688	163	Pipe Nipple, 1.5 NPT, Close	71057483
26	Elbow Fitting, AQ202414-2-4S	71056972	164	Hose, Heater, 2 ID x 2.5 OD	71033492
26	Tee Fitting, AQ 2028-4-4S	52181	165	Reducer Bushing, 2.5 NPT x 2 NPT Galv.	71057459
27	Tubing, Stainless Steel 1/4 OD x .035W	52520	166	Pipe Tee, Reducer 2 x 1.5 x 2 NPT	71057442
31	Fitting, Nipple, 1/4 NPT x 2, Galv	50859	167	Pipe Nipple, 2 NPT, Close	71057467
32	Retainer Ring, TRUARC #5100-125-S-ZD	50904	168	Pipe Nipple, 2 NPT x 8-3/4	71057475
33	‘O’ Ring, Parker #2-276	51458	169	Pipe Elbow, 2 NPT	71057434
36	Retainer Ring, TRUARC #N5000-244	52298	171	Pipe Nipple, 1-1/4 NPT, Close, Galv.	51704
38	Retainer Ring, TRUARC #5160-118	51872	172	Pipe Elbow, Street, 1-1/4 NPT, Galv	71127484
39	Capscrew,SOCH, G8, 1/2NC x 1-3/4	52380	182	Capscrew, HH, G5, 5/8 NC x 1-1/2	71128193
43	‘O’ Ring, Parker #5-381	71032627	186	Rivet, Drive-SS, #6 x .37	50915
45	Capscrew, HH, G5, 3/4NC x 1-3/4	52829	192	Capscrew, HH, G5, 1/2NC x 1	51086
46	Lockwasher, ZP, 3/4	51012	194	Lockwasher, ZP, 3/8	50200
47	‘O’ Ring, Parker #2-269	51460	195	Plug, 1/8 NPT	54246
50	Capscrew, SOCH, G8, SC1, 9/16NC x 5-1/2	71112270	196	Capscrew, HH, G5, 3/8 NC x 1	51780
55	‘O’ Ring, Parker #2-170	52149	200	Capscrew, SOCH, G8, 1/2 NC x 1-1/4	52317
83	Nut, Lock, ZP, 9/16 NC	71112288	205	Retainer Ring, TRUARC N5000-87	902A45-632
102	Cotter Pin,SST, 1/8 Dia x 1	51937	213	Eye Bolt, 5/8 Dia, Shank 1", Eye ID 1-3/8, 5/8 NC	KU-888
108	Nut, HH, ZP, 3/4 NC	50152	224	Washer, ZP, 1/4	51676
108	Nut, Jam, ZP, 1 NF	54570	225	Pipe Plug, SOCH, 3/8 NPT, Galv	54912
111	Fitting, Reducer, 3/8 - 1/4 NPT	52331	229	Button Head Screw, 1/4-20 x 1/2	K5B-541
111	Fitting, Nipple, 3/8 NPT, Close	52006	236	Cotter Pin, SST, 3/32 Dia x 1	53456
113	Fitting, Parker #20642-4-4	52329	237	Pin Nut, Castle, 3/4 NF	D02-394
113	Fitting, Hose End, AQ #4797-4B	51029	244	‘O’ Ring, Parker #2-248	20A11CM248
114	Elbow, Parker 4-4 CTX-S	51805	246	Grease Fitting, Alemite #1610-BL	53095
114	Elbow, AQ 2024-6-4S	54272	253	Capscrew, SOCH, G8, 1/2 NC x 5	51471
115	Hose, Parker #421-4	52328	255	Capscrew, SOCH, G8, 3/8 NC x 3/4	71326110
115	Hose, 1/4 ID x 1/2 OD, 250 PSI W.P.	50923	257	Capscrew, SOCH, G8, 3/8 NC x 1-1/4	51766
116	Capscrew, HH, ZP, G5, 5/8 NC x 1-1/2	71128193	258	Capscrew, SOCH, G8, 1/4 NC x 2-1/4	51079
116	Capscrew, HH, ZP, G5, 5/8 NC x 2	52014	270	Adjusting Screw, SOCH, G8, 3/8 NC x 1-3/4	53545
117	Lockwasher, ZP, 5/8	51008	271	Nut, Jam, ZP, 3/8 NC	50176
119	Capscrew, HH, ZP, G5, 5/8 NC x 1-1/2	71128193	302	Capscrew, HH, ZP, G8, 3/8 NC x 3/4	50853
120	Nut, HH, 5/8 NC	50913	304	Lockwasher, SST, 3/8	51581
123	Washer, ZP, 9/16	50890	309	Pipe Plug, SOCH, 1-1/4 NPT, Galv	71263297
127	Screw, Adjusting, SQH, G5, 5/8 NC x 4	71033104	321	Elbow, Fitting, AQ 2024-20-24S	54270
127	Screw, Adjusting, SQH, G8, 5/8 NC x 4-1/2	53092	322	Hose End, AQ 4411-24S	54738
129	Washer, SST, 1/2	52914	323	Hose, AQ FC300-24,	54737
138	Retainer Ring, TRUARC 5160-50	54370	324	Elbow, Fitting, AQ 202414-4-4S	71149975
150	Capscrew, HH, SST, 3/8 NC x 2-1/4	51579	325	Elbow Fitting, AQ 2024-4-4S	52182
154	Lockwasher, ZP, 3/8	50200	333	Capscrew, G8.8, 1.5P, M10 x 25	54681
154	Lockwasher, SST, 3/8	51581	334	Lockwasher, ZP, 7/16	50893

Legend:
 AQ = Aero Quip Fitting
 HH = Hex Head
 Galv = Galvanized
 NC = National Course Thread

SOCH = Socket Head (requires Allen wrench/bit)
 SST = Stainless Steel
 G5 = Grade 5 Fastener
 NF = National Fine Thread

SQH = Square Head
 ZP = Zinc Plated
 G8 = Grade 8 Fastener
 NPT = National Pipe Thread

COMMON PARTS LIST (CONTINUED)

ITEM NO.	DESCRIPTION OF PART	PART NUMBER	ITEM NO.	DESCRIPTION OF PART	PART NUMBER
337	Capscrew, HH, G5, 3/8 NC x 1	50829	663	Nut, ZP, #10NF	54142
338	Nipple Fitting, AQ 2083-4-4S	54274	665	Capscrew, SOCH, G8, #10 NC x 1-1/2	54493
339	Fitting, Pipe Tee, AQ 2090-4-4S	54678	669	Capscrew, Phillips HD, #6 NC x 5/8	71055966
340	Adapter Fitting, AQ 2021-4-4S	51814	673	Capscrew, Flat HD, SST, G5, #10 NF x 3/8	53869
346	Adapter Fitting, AQ 2022-2-4B	71048284	679	Lockwasher, ZP, 1/4	51801
348	Fitting Connector, AQ 2012-2-4B	71048268	681	Capscrew, Phillips HD, Brass, 1/4 NC x 1/2	71007009
349	Hose Tie, Nylon Tie Wrap 11 long	54235	686	Fitting Tee, AQ 2091-4-4S	54977
357	Elbow Fitting, AQ 2024-2-4S	51281	688	Capscrew, SOCH, G8, 5/16 NC x 3	71053763
357	Fitting, Barbed, Brass, 1/8	71062889	692	Nut, Lock, ZP, 5/16 NC	54171
378	Pin Lock Washer, #8, External teeth.	D02-138	696	Washer, ZP, 1/5	50182
380	Lockwasher, #8	H54U-352-10	701	Capscrew, Button HD, SST, #10 NC x 1/2	71127054
381	Handle Screw, Brass, #8-32 x 1/2	HRE20A-68	702	Washer, SST, #10	71320964
382	Fitting Connector, AQ 2021-2-4S	52092	711	Hose, AQ FC300-16	51003
383	Pipe Plug, SOCH, 1/16 NPT, Galv.	54247	712	Hose End, AQ 4411-16S	51002
401	Grease Fitting, SST, Alemite 1961-S	71111942	713	Fitting Elbow, AQ 2024-16-16S	51001
402	Lockwasher, SST, 3/8	51581	716	Pipe Nipple, 1 NPT x 2	71320907
403	Capscrew, HH, SST, G5, 3/8 NC x 1	71316483	717	Fitting Elbow, Street Elbow, 1 NPT, Galv	54243
412	Washer, ZP, 3/8	50177	718	Fitting, Nipple, 1 NPT, Close, Galv	50933
413	Nut, Lock, ZP, 3/8 NC	50170	719	Fitting, Connector, AQ 2021-16-16	71308258
421	Nut, Lock, ZP, 1/4 NC	53541	720	Fitting Elbow, 1 NPT, Galv	50928
424	Pipe Nipple, 1/8 NPT, Close	52191	725	Capscrew, SOCH, SST, 3/8 NC x 2-1/2	71319073
482	Fitting, AQ 2089-4-4S	71034714	726	Nut, Lock, SST, 3/8 NC	71320931
483	Fitting, Tee, AQ 2030-2-4S	54081	727	Plug, SOCH, 1 NPT, Galv	52304
484	Fitting Elbow, AQ 191321-4	52179	729	Bushing, Reducer, 1-1/4 x 1 NPT	71320932
485	Pipe Fitting, Street Elbow, 1-1/2 NPT, Galv	71273676	736	Capscrew, SOCH, SST, 3/8 NC x 5-1/2	71069041
487	Fitting Hose, Voss JB 0402-k	71078158	737	Plug, SOCH, 1 NPT, Galv	52304
488	Swivel Tee, AQ 203102-4-4S	71067789	738	Fitting Elbow, 45 Elbow, 1 NPT, Galv	54244
489	Capscrew, SOCH, G8, 3/8 NC x 2-1/2	50848	739	Lockwasher, SST, 1/2	71320956
492	Pipe Fitting, Union, 1-1/2 NPT, Galv	71149355	741	Capscrew, SOCH, SST, 1/2 NC x 2	71320949
515	Fitting Elbow, AQ GG310-NP04-02	71327316	754	Fitting, Elbow, AQ 2003-4-4B	54869
531	Capscrew, SOCH, 6mm x 1-1/4	71327324	755	Fitting, Elbow, Street 1/4 NPT	52803
535	Pipe Bushing, 1-1/2 x 1-1/4 NPT, Galv	51706	756	Plug, SOCH, SST, 1 NPT	71069017
537	Fitting Elbow, AQ 2085-4-4S	54273	759	Capscrew, HH, SST, 3/8 NC x 5-1/2	71328199
543	Capscrew, SOCH, G8, 3/8 NC x 1-1/2	54240	761	Fitting, Nipple, 1/4 NPT, Close	51034
605	Plug, AQ 2082-4S	50860	762	Fitting, Tee, 1-1/2, Galv	51718
616	Fitting Tee, AQ 2091-4-4S	K6U-926	763	Fitting, Bushing, 1-1/4 x 1 NPT, Galv	51705
617	Fitting Connector, AQ 2083-4-2	54679	764	Fitting, Union, 1 x 1 NPT, Galv	71328330
620	Fitting Elbow, AQ 2089-2-2S	71063473	765	Fitting, Nipple, 1 NPT x 2	71328314
621	Fitting Connector, AQ 2022-2-4S	71110894	767	Fitting, Nipple	71328249
654	Capscrew, HH, ZP, G5, 3/8 NC x 2	51769	768	Nut, Lock, SST, 3/8 NC	71069132
656	Fitting Tee, AQ 2033-4-4S	53940	772	Fitting, Connector, AQ 2021-8-8S	54943
662	Lockwasher, ZP, 3/16	52909	773	Fitting, Tube Extension, 1/4 NPT x 6 long	71325591

Legend:
 AQ = Aero Quip Fitting SOCH = Socket Head (requires Allen wrench/bit) SQH = Square Head
 HH = Hex Head SST = Stainless Steel ZP = Zinc Plated
 Galv = Galvanized G5 = Grade 5 Fastener G8 = Grade 8 Fastener
 NC = National Course Thread NF = National Fine Thread NPT = National Pipe Thread

PARTS ORDERING INFORMATION

The use of other than **Ingersoll-Rand** Material Handling replacement parts may result in decreased winch performance, and may, at the company's option, invalidate the warranty. For your convenience and future reference it is recommended that the following information be recorded.

Model Number _____

Serial Number _____

Date Purchased _____

When ordering replacement parts, please specify the following:

1. Complete model number and serial number as it appears on the nameplate.
2. Part number(s) and part description as shown in this manual.
3. Quantity required.

The nameplate is located on the winch outboard upright.

NOTICE

- **Continuing improvement and advancement of design may cause changes to this equipment which are not included in this manual. Manuals are periodically revised to incorporate changes. Always check the manual edition number on the front cover for the latest issue.**
- **Sections of this manual may not apply to your winch.**

Return Goods Policy

Ingersoll-Rand will not accept any returned goods for warranty or service work unless prior arrangements have been made and written authorization has been provided from the location where the goods were purchased.

Winches which have been modified without **Ingersoll-Rand** approval, mishandled or overloaded will not be repaired or replaced under warranty. A printed copy of the warranty which applies to this winch is provided inside the back cover of this manual.

Disposal

When the life of the unit has expired, it is recommended that it be disassembled, degreased and parts separated as to materials so that they may be recycled.

For additional information contact:

Ingersoll-Rand Material Handling

P.O. Box 24046
 2724 Sixth Avenue South
 Seattle, WA 98124-0046 USA
 Phone: (206) 624-0466
 Fax: (206) 624-6265

or

Ingersoll-Rand Material Handling

Douai Operations
 111, Avenue Roger Salengro
 59450 Sin Le Noble, France
 Phone: (33) 3-27-93-08-08
 Fax: (33) 3-27-93-08-00

For additional information on the following products order the publication by the reference Part/Document number listed:

PUBLICATION	PART/DOCUMENT NUMBER
Brake Lining Replacement	MHD56142
Operation Manual—CE Version	MHD56101

LIMITED WARRANTY

Ingersoll-Rand Company (I-R) warrants to the original user its Hoists and Winches (Products) to be free of defects in material and workmanship for a period of one year from the date of purchase. **I-R** will repair, without cost, any Product found to be defective, including parts and labor charges, or at its option, will replace such Products or refund the purchase price less a reasonable allowance for depreciation, in exchange for the Product. Repairs or replacements are warranted for the remainder of the original warranty period.

If any Product proves defective within its original one year warranty period, it should be returned to any Authorized Hoist and Winch Service Distributor, transportation prepaid with proof of purchase or warranty card.

This warranty does not apply to Products which **I-R** has determined to have been misused or abused, improperly maintained by the user, or where the malfunction or defect can be attributed to the use of non-genuine **I-R** parts.

I-R makes no other warranty, and all implied warranties including any warranty of merchantability or fitness for a particular purpose are limited to the duration of the expressed warranty period as set forth above. I-R's maximum liability is limited to the purchase price of the Product and in no event shall I-R be liable for any consequential, indirect, incidental, or special damages of any nature rising from the sale or use of the Product, whether based on contract, tort, or otherwise.

Note: Some states do not allow limitations on incidental or consequential damages or how long an implied warranty lasts so that the above limitations may not apply to you.

This warranty gives you specific legal rights and you may also have other rights which may vary from state to state.

IMPORTANT NOTICE

It is our policy to promote safe delivery of all orders.

This shipment has been thoroughly checked, packed and inspected before leaving our plant and receipt for it in good condition has been received from the carrier. Any loss or damage which occurs to this shipment while enroute is not due to any action or conduct of the manufacturer.

Visible Loss or Damage

If any of the goods called for on the bill of lading or express receipt are damaged or the quantity is short, do not accept them until the freight or express agent makes an appropriate notation on your freight bill or express receipt.

Concealed Loss or Damage

When a shipment has been delivered to you in apparent good condition, but upon opening the crate or container, loss or damage has taken place while in transit, notify the carrier's agent immediately.

Damage Claims

You must file claims for damage with the carrier. It is the transportation company's responsibility to reimburse you for repair or replacement of goods damaged in shipment. Claims for loss or damage in shipment must not be deducted from the **Ingersoll-Rand** invoice, nor should payment of **Ingersoll-Rand** invoice be withheld awaiting adjustment of such claims as the carrier guarantees safe delivery.

You may return products damaged in shipment to us for repair, which services will be for your account and form your basis for claim against the carrier.

United States Office Locations

For Order Entry and Order Status

**Ingersoll-Rand
Distribution Center**
P.O. Box 618
510 Hester Drive
White House, TN 37188
Phone: (615) 672-0321
Fax: (615) 672-0801

Technical Support

**Ingersoll-Rand
Material Handling**
P.O. Box 24046
2724 Sixth Avenue South
Seattle, WA 98124-0046 USA
Phone: (206) 624-0466
Fax: (206) 624-6265

Web Site:

www.ingersoll-rand.com

Regional Sales Offices

Chicago, IL
888 Industrial Drive
Elmhurst, IL 60126
Phone: (630) 530-3800
Fax: (630) 530-3891

Detroit, MI
1872 Enterprise Drive
Rochester, MI 48309
Phone: (248) 293-5700
Fax: (248) 293-5800

Houston, TX
450 Gears Road
Suite 210
Houston, TX 77067-4516
Phone: (281) 872-6800
Fax: (281) 872-6807

Los Angeles, CA
11909 E. Telegraph Road
Santa Fe Springs, CA
90670-0525
Phone: (562) 948-4189
Fax: (562) 948-1828

Philadelphia, PA
P.O. Box 425
900 E. 8th Ave., Suite 103
King of Prussia, PA 19406
Phone: (610) 337-5930
Fax: (610) 337-5912

International Office Locations

Offices and distributors in principal cities throughout the world. Contact the nearest **Ingersoll-Rand** office for the name and address of the distributor in your country or write/fax to:

**Ingersoll-Rand
Material Handling**
P.O. Box 24046
2724 Sixth Avenue South
Seattle, WA 98124-0046 USA
Phone: (206) 624-0466
Fax: (206) 624-6265

Canada

**National Sales Office
Regional Warehouse
Toronto, Ontario**
51 Worcester Road
Rexdale, Ontario
M9W 4K2
Phone: (416) 213-4500
Fax: (416) 213-4510
Order Desk
Fax: (416) 213-4506

**Regional Sales Offices
Edmonton, Alberta**
1430 Weber Center
5555 Calgary Trail SB
Edmonton, Alberta
T6H 5P9
Phone: (780) 438-5039
Fax: (780) 437-3145

Montreal, Quebec
3501 St. Charles Blvd.
Kirkland, Quebec
H9H 4S3
Phone: (514) 695-9040
Fax: (514) 695-0963

British Columbia
1200 Cliveden Avenue
Delta, B. C. V3M 6G4
Phone: (604) 523-0803
Fax: (604) 523-0801

**Latin America Operations
Ingersoll-Rand
Production Equipment Group**
730 N.W. 107 Avenue
Suite 300, Miami, FL, USA
33172-3107
Phone: (305) 559-0500
Fax: (305) 222-0864

Europe, Middle East and Africa

**Ingersoll-Rand
Material Handling
Douai Operations**
111, avenue Roger Salengro
59450 Sin Le Noble, France
Phone: (33) 3-27-93-08-08
Fax: (33) 3-27-93-08-00

Asia Pacific Operations

Ingersoll-Rand Asia Pacific Inc.
Suite 1201-3, 12/F
Central Plaza
18 Harbour Road
Wanchai, Hong Kong
Phone: (852) 2527 0183
Fax: (852) 2529 5976

Russia

Ingersoll-Rand
Kuznetsky Most 21/5
Entrance 3
Moscow 103895 Russia
Phone: 7-501-923-9134
Fax: 7-501-924-4625