

SIZES HU, HUL, H5U AND H5UL SINGLE DRUM UTILITY® WINCHES

WARNING

***These Winches are not to be used
for lifting or lowering people***

LUBRICATION

Warning: Lubricate the motor before using the Winch. To avoid leakage during shipment, the oil was drained from the motor. A quantity of oil sufficient for one filling is contained in the can packed with the Winch. Before using the Winch, make certain the three Plugs (2 and 3) are securely threaded into place. Unscrew the Vent Cap (4) and pour the entire contents of the can into the opening in the top of the Motor Case (1).

Motor Lubrication

Check oil daily and maintain level with opening in the side of the Motor Case.

When the Winch is subjected to temperatures above 32° F (0° C): After the Winch has been idle for several hours or overnight, loosen the Drain Plug (2) located at the bottom of the Motor Case (1) and allow the accumulated water to drain out. After draining the water, tighten the Plug in the bottom and remove a similar Plug on the side of the Motor Case. Unscrew the Vent Cap (4) and pour a sufficient quantity of the recommended oil through the opening to bring the oil level up to the side opening. Replace the Plug and Vent Cap.

When the Winch is subjected to temperatures below 32° F (0°): Allow the Winch to remain idle long enough for the water content in the Motor Case (1) to separate from the oil, but not long enough for it to freeze. Drain the water and replenish the oil as above. Should this procedure be impractical, drain the entire contents from the Motor Case immediately after operation ceases, and pour the oil back into the Motor Case before resuming operation. If not drained, a sufficient quantity of water will eventually accumulate so that the Oil Splasher (37), which is attached to the Crank (36), will freeze fast. *(Continued on Page 2.)*

HOW TO ORDER

Order all repair parts for your Ingersoll-Rand Tool by the **NAME** and **NUMBER** shown in the Repair Part List section. **Never** use the illustration numbers which appear in the first column.

For prompt service and genuine Ingersoll-Rand parts, place orders with the nearest Ingersoll-Rand Office or Authorized Distributor.

Notice: The use of other than genuine Ingersoll-Rand replacement parts may result in decreased tool performance and increased maintenance, and may, at the Company's option, invalidate all warranties.

Refer All Communications to the Nearest
Ingersoll-Rand Office or Distributor.

© Ingersoll-Rand Company 1979

Printed in U.S.A.

 **Ingersoll-Rand.**

**P
A
R
T
S**

**B
U
L
L
E
T
I
N**

Motor Lubrication (Continued)

For Temperatures 30° to 80° F (-1° C to 26° C) use Ingersoll-Rand Medium Oil No. 50 or SAE 20 or 20W Motor Oil.

For Temperatures below 30° F (-1° C) use SAE 10 or 10W Motor Oil.

For Temperatures above 80° F (26° C) use SAE 30 Motor Oil.

Throttle Valve Lubrication

Weekly, insert a small quantity of Ingersoll-Rand Light Grease No. 28 or a good quality No. 2 cup grease into the Grease Fittings (14) located in the Valve Chest (10). Two or three strokes from the No. P25-228 Grease Gun is an ample amount for each fitting.

Gearing Lubrication

Every sixty to ninety days, remove the Grease Plug (108) from the Gear Case (84) and note if the visible portion of the gears is coated with grease. If the gears appear to lack lubrication, add approximately 1/2 pint (240 mL) of the recommended grease. When reassembling a Winch, approximately two pounds (1 kg) of grease is required.

Use Ingersoll-Rand Heavy Gear Grease No. 70. As a substitute, Ingersoll-Rand Light Grease No. 28 or a good quality No. 2 Cup Grease may be used.

For extremely low temperatures, Ingersoll-Rand Medium Gear Grease No. 75, low temperature grease or a heavy gear oil may be used. **Note:** Leakage will probably be experienced if heavy gear oil is used for normal temperatures.

Lubricate the Drum Gear occasionally by pushing a piece of hard stick or block grease 3/4" to 1" (19 mm to 25 mm) long through the hole above the Drum Shaft Long Set Screw (75).

Air Line Lubricators are recommended for use with Utility Winches. Their use will improve the efficiency and prolong the life of the motor.

HOSE AND HOSE CONNECTIONS

Use 1-1/4" (32 mm) hose with a suitable hose fitting for attaching it to the inlet. Use of smaller hose and fittings will reduce the efficiency of the Winch.

MOUNTING

Mount the Winch so that the axis of the Rope Drum (67) is horizontal. Operation of the Winch with the axis of the Drum more than 10° from horizontal will result in lubrication difficulties and the Wire Rope will tend to pile up on the low end of the Drum.

On all Winches with four-cylinder motors, the Motor Case (1) can be rotated on the Motor Mounting Bracket (66) to any one of eight different positions. When a Winch is shipped from the factory, the Motor Case is positioned for operation when the Winch is mounted upright on its base. Therefore, the Motor Case must be repositioned on a Winch which is to be mounted in such a way that the Vent Cap (4) is more than 25° off top vertical center.

To change the position of the Motor Case:

1. Drain the oil.
2. Unscrew the eight Motor Case Screws (57).
3. Rotate the Motor Case to bring the Vent Cap as near top vertical center as possible.
4. Replace the Cap Screws.
5. Fill with oil.

On H5U and H5UL Winches, the Motor Case can be rotated to any one of five different positions. The Motor Case must be repositioned on either of these sizes when the Winch is to be mounted in such a way that the Drain Plug (2) is more than 25° off bottom vertical center. To change the position of the Motor Case:

1. Drain the oil.
2. Unscrew the ten Motor Case Screws (57).
3. Rotate the Motor Case to bring the Vent Cap as near bottom vertical center as possible.
4. Replace the Cap Screws.
5. Fill with oil.

The Winch should not be operated in such a position that one of the Cylinders (48) is directly at the bottom.

MAINTENANCE INSTRUCTIONS

Apply the Wire Rope to wind on the Rope Drum in the direction indicated by the instruction plate on the Winch.

Adjust the brake on Winches over serial 14 000 so that considerable pressure is required to push the Brake Handle (126) past center for locking. Make adjustment by removing the Brake Shoe Long Pin (131) and rotating the Brake Adjusting Screw (130).

Remove the Throttle Valve Spring (21), Poppet Throttle Valve (20) and Throttle Valve Ball (22) from the Valve Chest (10) before attempting to withdraw the Reverse Valve (24) from the Reverse Valve Bushing (13).

The following procedure is recommended when replacement of the Rotary Valve Bushing (12) or Reverse Valve Bushing (13) is necessary:

1. Unscrew the Valve Chest Screws (18) and remove the Valve Chest Cover (17).
2. Screw a No. HU-932 Jack Bolt into each tapped lug on the Valve Chest (10) until the Jack Bolts contact the Motor Case (1). Turn each Bolt a little at a time to jack the Chest with assembled parts from the Motor Case.
3. Unscrew the Throttle Valve Cap (23) and remove the Spring (21), Poppet Throttle Valve (20) and Ball (22) from the Valve Chest (10).
4. Withdraw the Rotary Valve (25) and Reverse Valve (24), and remove the Throttle Lever Spring (35).
5. Support the face of the Valve Chest (10) that contacts the Motor Case (1), and press out the two Bushings with an arbor **that will clear the Bushing Keys (11)**. **Caution:** Failure to use an arbor that will clear the Bushing Keys, or pressing the Bushings in the opposite direction than instructed will destroy the Keys.
6. Support the face of the Valve Chest (10) that contacts the Valve Chest Cover (17), align the keyslot in the new Reverse Valve Bushing with the Bushing Key (11) and press the Bushing into the Chest until the leading face of the Bushing is flush with the supported face of the Chest. Align the keyslot in the new Rotary Valve Bushing with the Bushing Key and press the Bushing into the Chest until the Bushing shoulder is flush with the supported face of the Chest.
7. Insert the No. 23470 Throttle Valve Stem Reamer or a .505" (12.8 mm) hand reamer through the throttle valve chamber in the Valve Chest and ream the hole through the wall of the new Reverse Valve Bushing.
8. Check the fit of the Rotary Valve (25) in the new Rotary Valve Bushing. If the Valve is tighter than a good running fit in the Bushing, lap in the Valve, using a fine grain lapping compound whose abrasive agent will break up rapidly. Remove all trace of the compound with kerosene after obtaining the desired fit.
9. Check the fit of the Reverse Valve (24) in the new Reverse Valve Bushing. If the fit is too tight, ream the Bushing as follows:

1.750" (44.4 mm) for four-cylinder motors.

1.875" (47.6 mm) for five-cylinder motors.

Caution: The Reverse Valve is chrome plated; do not lap.

10. Rotate the Reverse Valve in the Reverse Valve Bushing until the arrows on the two parts align, and install the Throttle Valve Ball, Poppet Throttle Valve, Spring and Cap.
11. Install the Throttle Lever Spring (35) and Throttle Control Arm (28).
12. Align the holes through the Valve Chest (10) with those in the face of Motor Case (1) and squarely start the protruding end of the Rotary Valve Bushing into the Case. Place a hardwood block on the chest face and press or drive in the Bushing until the Valve Chest contacts the Motor Case.

The two sections of the Crank (36) are matched before final machining, and the web of each section is stamped with an identification mark as AA17, CC21, XX19, etc. Only sections bearing identical markings can be used together. If more than one Crank is disassembled at one time, be sure only matched parts are assembled together.

Slide the Crank Pin Sleeve (39), plain end first, onto the crank pin when assembling the Crank (36).

Install the Connecting Rod Rings (44) so that the internally beveled ends are toward the Connecting Rods (43) when assembling the Crank (36).

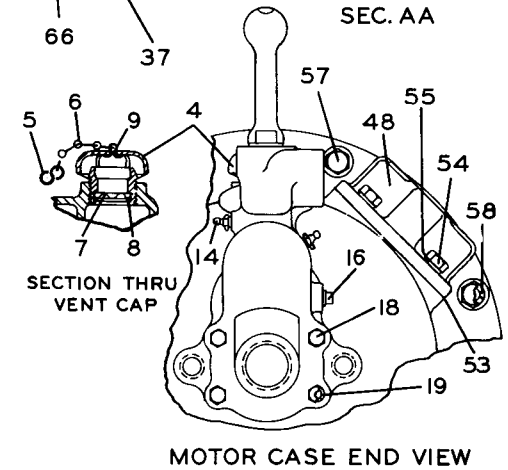
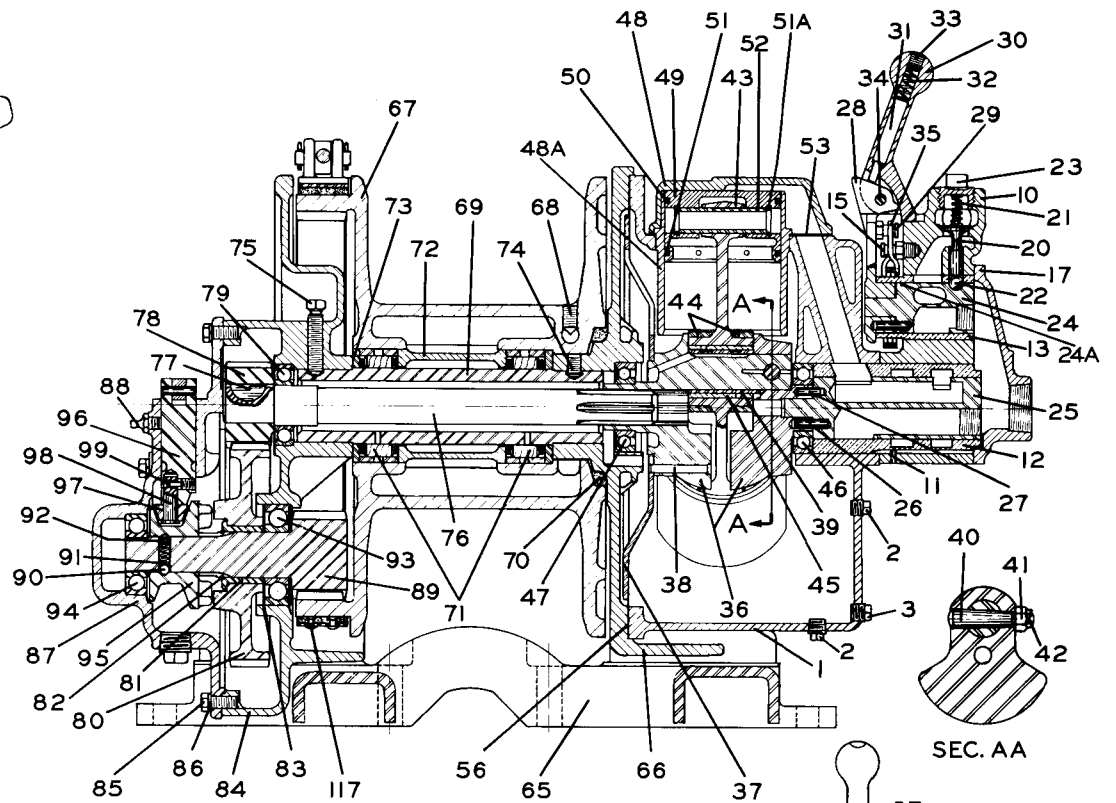
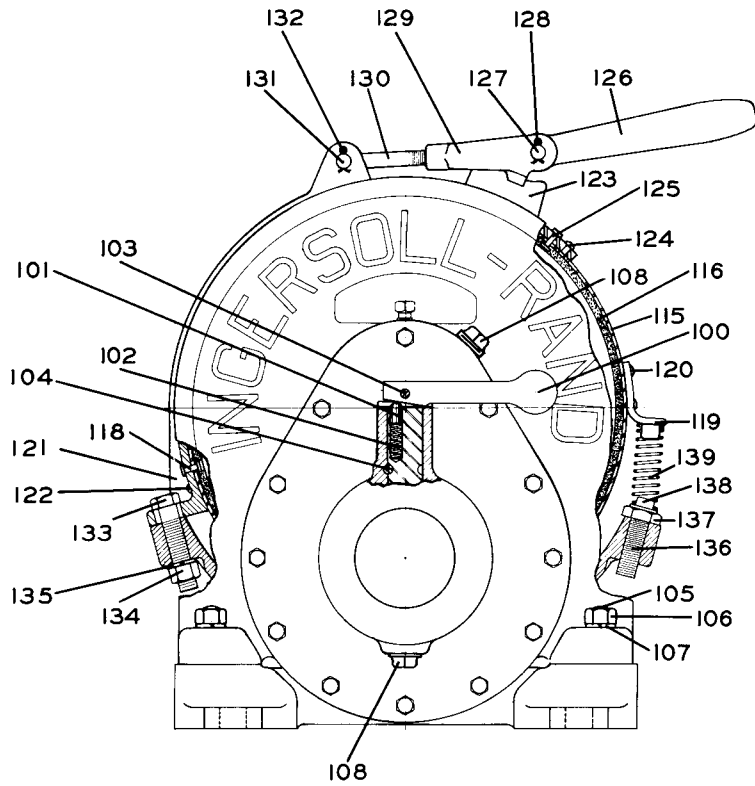

Size HU Utility Winch
Beginning Serial 14 000
This construction is typical of Sizes HUL, H5U and H5UL

PART NUMBER FOR ORDERING

PART NUMBER FOR ORDERING

		PART NUMBER FOR ORDERING				PART NUMBER FOR ORDERING	
		HU, HUL	H5U, H5UL			HU, HUL	H5U, H5UL
	Motor Assembly.	HU-A501	H5U-A501	28	Throttle Control Arm	HU-555A	HU-555A
1	Motor Case.	HU-501	HH5D-501	29	Throttle Lever Spring Stop Pin	D02-553	D02-553
2	Drain Plug (2)	D02-402	D02-402	● 30	Throttle Lever.	HU-556	HU-556
3	3/8" Pipe Plug.	T1SE-368	-----	31	Throttle Lever Latch	HU-869	HU-869
*	1-1/4" Pipe Plug.	-----	ESUD-947	● 32	Throttle Lever Latch Spring	HU-567	HU-567
4	Vent Cap.	D02-303A	D02-303A	33	Throttle Lever Set Screw.	HU-842	HU-842
5	S-Hook	D02-421	D02-421	34	Throttle Lever Pin	HU-870	HU-870
6	Vent Cap Chain	D02-891	D02-891	*	Throttle Lever Pin Cotter (2)	D02-524	D02-524
7	Vent Cap Screen	D02-889	D02-889	● 35	Throttle Lever Spring.	HU-412	HU-412
8	Vent Cap Screen Retainer	6CND-233-1/2	6CND-233-1/2	36	Crank Assembly.	HU-A516	H5U-A516
9	Vent Cap Cotter.	D02-893	D02-893	37	Crank Bare (consists of 2 matched parts which are not sold separately).	HU-516	HU-516
	Valve Chest Assembly			38	Oil Splasher	HU-540	HU-540
	for Winch with Standard Brake	HU-A545A	H5U-A545	39	Oil Splasher Long Rivet (2)	HU-541	HU-541
	for Winch with Automatic			*	Oil Splasher Short Rivet (2)	231-712	231-712
	Brake.	HU-B545A	H5U-B545	● 39	Crank Pin Sleeve	HU-519	HU-519
10	Valve Chest	HU-545A	H5U-545	40	Crank Lock Pin	HU-520	HU-520
11	Bushing Key (2).	HU-538	HU-538	41	Crank Lock Pin Nut	D02-394	D02-394
12	Rotary Valve Bushing	HU-525S	HH5D-525S	42	Crank Lock Pin Cotter	D02-524	D02-524
13	Reverse Valve Bushing	HU-945S	H5U-945S	● 43	Connecting Rod (1 for each Cylinder)	HU-509A	HH5D-509
14	Grease Fitting (2)	23-188	23-188	44	Connecting Rod Ring (2)	HU-510	HU-510
15	Throttle Lever Spring Stop Pin	D02-553	D02-553	● 45	Connecting Rod Bushing.	HU-511	HU-511
16	Brake Inlet Plug.	D02-402	D02-402	● 46	Crank Valve End Bearing.	HU-518	HU-518
17	Valve Chest Cover.	HU-546A	H57-546	● 47	Crank Pin End Bearing.	HUD-895	HUD-895
18	Valve Chest Screw (4)	HU-548	HU-548		Cylinder Assembly (5 for Size H5U or H5L; 4 for HU, HUL)	HH5D-A505A	HH5D-A505A
19	3/8" Lock Washer (4)	D02-321	D02-321	48	Cylinder Head.	HH5D-H505A	HH5D-A505A
● 20	Poppet Throttle Valve	HU-940	KU-940	48A	Cylinder Sleeve	HH5D-L505A	HH5D-L505A
● 21	Poppet Throttle Valve Spring	HU-942	HU-942	49	Piston Assembly (1 for each Cylinder)	HU-A513B	HU-A513B
22	Poppet Throttle Valve Ball.	D10-280	D10-280	50	Piston Ring (1 for each Piston)	HU-337	HU-337
23	Poppet Throttle Valve Cap.	HU-943	KU-943	51	Oil Regulating Ring (1 for each Piston)	HU-338	HU-338
24	Reverse Valve			51A	Retaining Ring (2 for each Piston)	902A45-632	902A45-632
	for Winch with Standard Brake	HU-944	H5U-944	52	Piston Wrist Pin (1 for each Piston)	HU-514A	HU-514A
	for Winch with Automatic			● 53	Cylinder Gasket (1 for each Cylinder)	HU-507	HU-507
	Brake.	HU-744	H5U-744	54	Cylinder Cap Screw (4 for each Cylinder)	D10-354	D10-354
*	Reverse Valve O-ring			55	Cylinder Cap Screw Washer (copper) (4 for each Cylinder)	HU-504	HU-504
	for H5U, H5UL	-----	R0B2J73-359	● 56	Motor Case Gasket	HU-592	HH5D-592
	for HU, HUL	AF160-294	-----	57	Motor Case Screw (10 for Size H5U or H5UL, 8 for others)	215-148	215-148
25	Rotary Valve			58	1/2" Lock Washer (10 for Size H5U or H5UL, 8 for others)	D10-322	D10-322
	for Overwinding Winch						
	(Standard)	HU-526A	H5U-526				
	for Underwinding Winch						
	(Special)	HU-526RA	H5U-526R				
● 26	Large Valve Drive Pin.	HU-527	HU-527				
● 27	Small Valve Drive Pin (2)	HU-627	HU-627				

* Not illustrated.

● To keep downtime to a minimum, it is desirable to have on hand certain repair parts. We recommend that you stock one (pair or set) of each part indicated by a bullet (●) for every four tools in service.

PART NUMBER FOR ORDERING



PART NUMBER FOR ORDERING



65	Base		80	Intermediate Gear	
	for Size HU or H5U.	HU-564A		for Size HU or HUL all serials, and	
	for Size HUL or H5UL.	HUL-564A		Size H5U or H5UL under serial	
66	Motor Mounting Bracket.	H5U-502		29 500	HU-364
67	Rope Drum			for Size H5U or H5UL over serial	
	for Size HU or H5U.	H5U-324		29 500	H5U-364A
	for Size HUL or H5UL.	H5UL-324	81	Intermediate Gear Bushing.	HU-363
68	Wire Rope Set Screw (2).	HU-381	82	Intermediate Gear Bushing Retainer	HU-362
69	Drum Shaft		83	Fiber Washer.	HU-871
	for Size HU or H5U.	HU-459	84	Gear Case	HU-353A
	for Size HUL or H5UL.	HUL-459	85	Gear Case Screw (12).	D02-354
70	Drum Packing	HU-866	86	3/8" Lock Washer (13).	D02-321
● 71	Drum Bearing (2) (Hyatt C99211 or its equivalent).	HU-466	87	Gear Cover.	HU-352
72	Drum Bearing Spacer		88	Grease Fitting	23-188
	for Size HU or H5U.	HU-467	89	Drive Shaft.	HU-358
	for Size HUL or H5UL.	HUL-467	90	Clutch Jaw Lock Ball.	G601-65
73	Drum Bearing Plate (2).	HU-469	91	Clutch Jaw Lock Spring	HU-863
74	Drum Shaft Short Set Screw.	HU-867	92	Clutch Jaw Lock Plug	HU-864
75	Drum Shaft Long Set Screw	HU-868	● 93	Drive Shaft Inner Bearing	HU-359
76	Motor Shaft		● 94	Drive Shaft Outer Bearing	215-55
	for Size HU or H5U.	HU-316A	95	Clutch Jaw.	HU-568
	for Size HUL or H5UL.	HUL-316A	96	Clutch Eccentric Shaft	HU-857
77	Motor Pinion Key.	D04-320	97	Clutch Eccentric Roller	HU-858
78	Motor Shaft Pinion		98	Clutch Eccentric Pin	HU-859
	for Size HU or HUL all serials, and		99	Eccentric Pin Lock Screw	HU-860
	Size H5U or H5UL under serial		100	Clutch Lever.	HU-565
	29 500	HU-319A	101	Clutch Latch.	HU-566
	for Size H5U or H5UL over serial		102	Latch Spring.	HU-567
	29 500	H5U-319B	103	Clutch Lever Pin	HU-861
● 79	Motor Shaft Bearing	D10-518	104	Eccentric Shaft Lock Screw	HU-865
			105	Base Bolt (6) 5/8"-11 x 2-3/4" long	HU40-775
			105	Base Bolt (2) 5/8"-11 x 3" long.	215-228

● To keep downtime to a minimum, it is desirable to have on hand certain repair parts. We recommend that you stock one (pair or set) of each part indicated by a bullet (●) for every four tools in service.

PART NUMBER FOR ORDERING



PART NUMBER FOR ORDERING



106	Base Bolt Nut (8)	HU-776	118	Brake Lining Long Rivet (12)	HU-157
107	Base Bolt Lock Washer (8)	A-67	123	Brake Lever Bracket	HU-193
108	Grease Plug (2)	22SR-165	124	Brake Lever Bracket Rivet (4)	
	Brake Band Assembly			for Size HU or HUL	107-153
	for Size HU or HUL	HU-A152		for Size H5U or H5UL	23-712
● 115	Brake Band	H5U-A152	125	Brake Lining Long Rivet (4)	HU-157
	for Size HU or HUL	HU-152	● 126	Brake Handle	107-151
	for Size H5U or H5UL	H5U-152	127	Brake Handle Pin	107-149
116	Brake Lining	HU-155	128	Brake Handle Pin Cotter (2)	D02-330
117	Brake Lining Short Rivet (12)	K4U-156	129	Brake Yoke	107-159
118	Brake Lining Long Rivet (16)	HU-157	130	Brake Adjusting Screw	107-158
119	Brake Support Spring Bracket	K4U-161A	131	Brake Shoe Long Pin	107-147
120	Spring Bracket Rivet (2)		*	Brake Lever Bracket Pin	107-148
	for Size HU or HUL	107-153	132	Brake Shoe Pin Cotter (2)	D02-330
	for Size H5U or H5UL	23-712	133	Brake Anchor	HU-103
120	Brake Shoe Rivet (11)		134	Brake Anchor Nut	HU-776
	for Size HU or HUL	107-153	135	Brake Anchor Lock Washer	A-67
	for Size H5U or H5UL	23-712	136	Brake Support Screw	K4U-162
● 121	Brake Shoe	HU-145	137	Brake Support Screw Jam Nut	G7-18
122	Brake Shoe Rivet (9)		138	Brake Support Screw Washer	K4U-343
	for Size HU or HUL	107-153	139	Brake Support Spring	T03-119
	for Size H5U or H5UL	23-712	*	Brake Spring Cotter	107-146

7

* Not illustrated.

● To keep downtime to a minimum, it is desirable to have on hand certain repair parts. We recommend that you stock one (pair or set) of each part indicated by a bullet (●) for every four tools in service.

REMOTE CONTROL

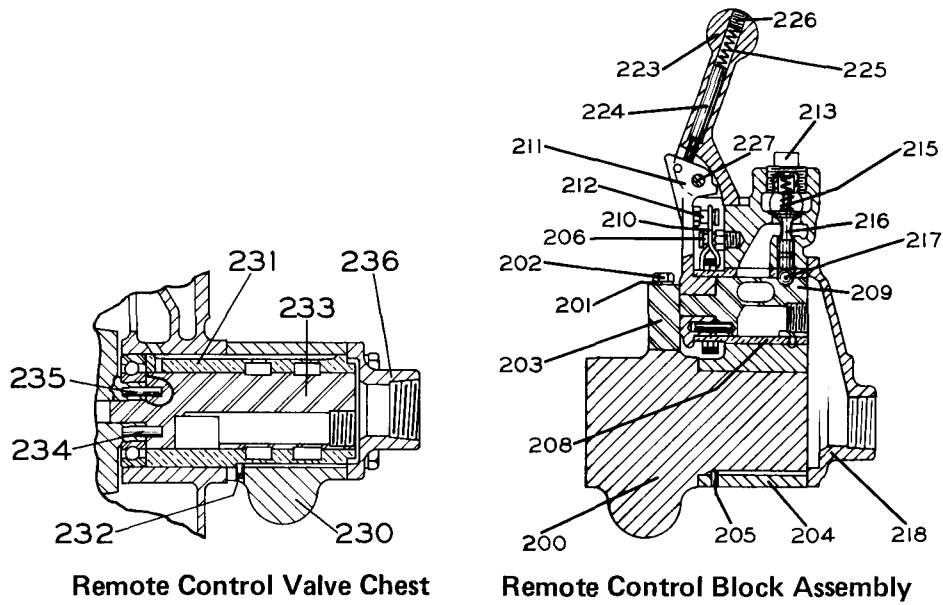

PART NUMBER FOR ORDERING

		HU, HUL	H5U, H5UL
	Remote Control Block Assembly		
	for Winch with Standard Brake	HU-A685	KU-A685
	for Winch with Automatic Brake	HU-B685	KU-B685
200	Remote Control Block	HU-685	KU-685
201	3/8" Lock Washer (2)	D02-321	D02-321
202	Control Arm Retainer Screw (2)	HU-865	HU-865
203	Control Arm Retainer	HU-687	HU-687
204	Control Block Valve Chest	HU-876A	KU-876A
205	Bushing Key (1 for H5U or H5UL; 2 for others)	HU-538	HU-538
*	Brake Inlet Plug	D02-402	D02-402
206	Throttle Lever Spring Stop Pin	D02-553	D02-553
208	Control Block Reverse Valve Bushing	HU-945	KU-945
*	Grease Fitting (2)	23-188	23-188
209	Control Block Reverse Valve		
	for Winch with Standard Brake	HU-944	KU-944
	for Winch with Automatic Brake	HU-744	KU-744
*	Reverse Valve O-ring	AF160-294	R0B2J73-359
210	Control Block Throttle Lever Spring	HU-412	KU-412
211	Control Block Throttle Arm	HU-555A	KU-555A
212	Throttle Lever Spring Stop Pin	D02-553	D02-553
213	Control Block Throttle Valve Cap	HU-943	KU-943
215	Control Block Throttle Valve Spring	HU-942	HU-942
216	Control Block Poppet Throttle Valve	HU-940	KU-940
217	Control Block Throttle Valve Ball	D10-280	D10-280
218	Control Block Valve Chest Cover	HU-546A	KU-546A
223	Control Block Throttle Lever	HU-556	HU-556
224	Throttle Lever Latch	HU-869	HU-869
225	Latch Spring	HU-567	HU-567
226	Throttle Lever Set Screw	HU-842	HU-842
227	Throttle Lever Pin	HU-870	HU-870
*	Throttle Lever Pin Cotter (2)	D02-524	D02-524

* Not illustrated.

REMOTE CONTROL (Cont.)

PART NUMBER FOR ORDERING

		HU, HUL	H5U, H5UL
	Remote Control Valve Chest Assembly	HU-A686	H5U-A686
230	Remote Control Valve Chest	HX-545	H5M-545
231	Rotary Valve Bushing	HU-525	HH5D-525
232	Bushing Key	HU-538	HU-538
233	Rotary Valve for Overwinding Winch (Standard)	HU-526A	H5U-526
	for Underwinding Winch (Special)	HU-526RA	H5U-526R
234	Large Valve Drive Pin	HU-527	HU-527
235	Small Valve Drive Pin (2)	HU-627	HU-627
236	Remote Control Valve Chest Cover	HX-546	HX-546
*	Valve Chest Screw (4)	HU-548	HU-548
*	3/8" Lock Washer (4)	D02-321	D02-321

* Not illustrated.

DRUM GUARDS

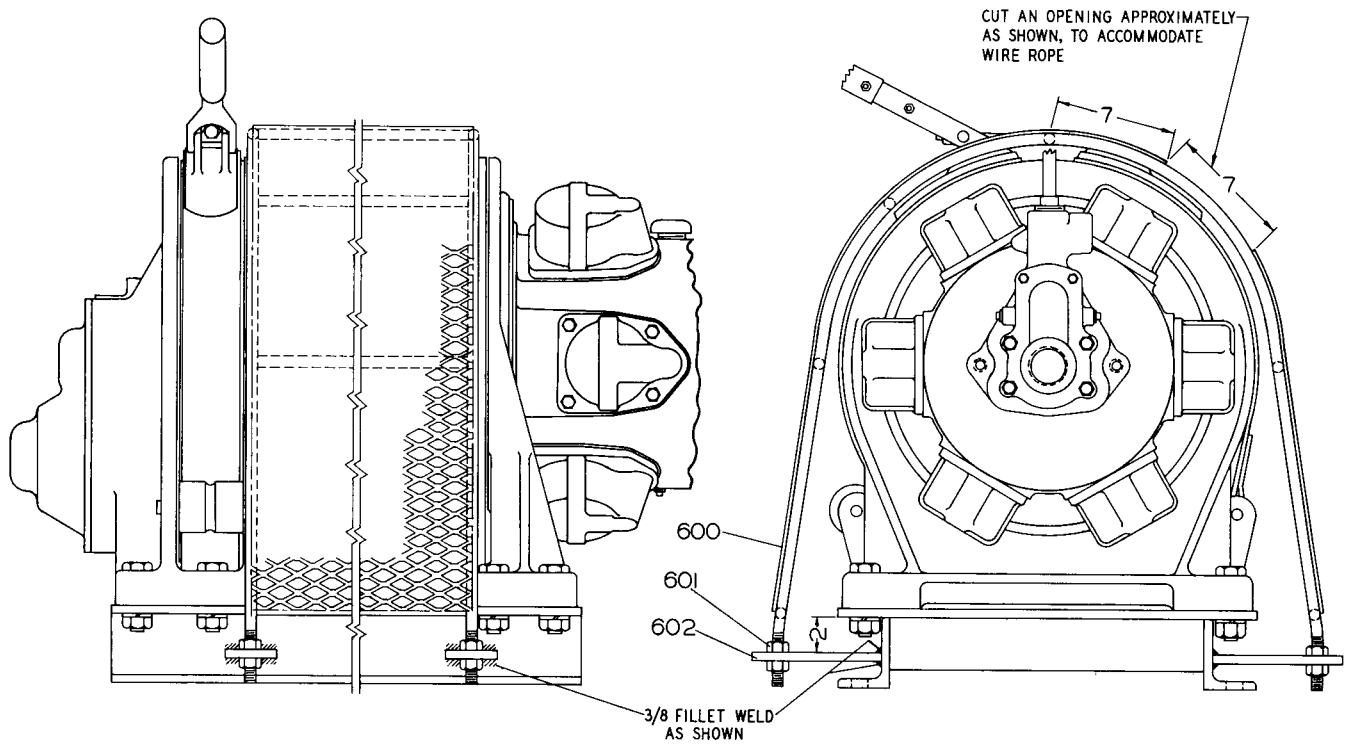

PART NUMBER FOR ORDERING

600	Drum Guard for HU or H5U	HU40-298
	for HUL or H5UL	HUL40-298
601	5/8"-11 thd. Nut (8)	K6U-8
602	Plate (4)	K6U-299

AUTOMATIC BRAKE

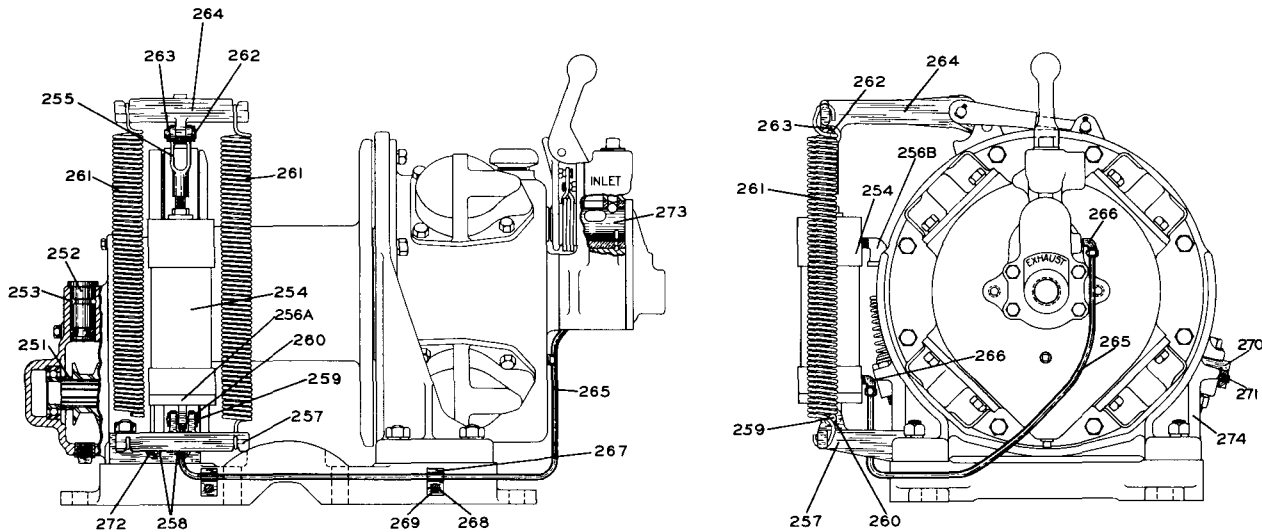

Series HU or H5U Winch with Automatic Brake Over Serial 14 000

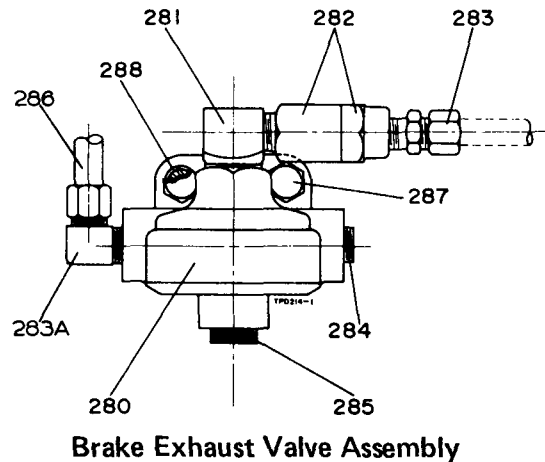

WARNING

DISENGAGING CLUTCH PARTS

For reasons of safety, it is emphatically recommended that Automatic Brake and Disengaging Clutch features not be used on any Winch used for hoisting or otherwise subjected to an overhauling load. If for any reason the Disengaging Clutch is left operative in a Winch used under either of the above conditions, it is the responsibility of the user to make provision to prevent accidental operation of the Winch motor with the clutch disengaged. **Operation of the motor with the clutch disengaged while holding a suspended load will allow the load to drop.**

Because the combination of Automatic Brake and Disengaging Clutch is not sanctioned, the three parts marked † should be ordered and installed if conversion from manual to automatic brake is made on a Winch equipped with the engaging clutch.

Use the parts as follows:

Install the Clutch Jaw Spacer (251) between the Drive Shaft Outer Bearing (94) and the Clutch Jaw (95) on the Drive Shaft (89) to lock the Clutch Jaw in engagement with the Intermediate Gear (80).

Remove the Clutch Eccentric Shaft (96) and included parts along with the Clutch Lever (100). Insert the Gear Cover Plug Seal (253) and Plug (252) into the hole in the Gear Cover (87) previously occupied by the Eccentric Shaft.

PART NUMBER FOR ORDERING



‡ 251	Clutch Jaw Spacer	HU-712
‡ 252	Gear Cover Plug	HU-728
‡ 253	Gear Cover Plug Seal	HU-730
254	Brake Cylinder	HU-720
*	Brake Cylinder Bushing	HU-771
255	Brake Cylinder Yoke	HU-719A
256	Brake Connection Bushing	HU-547
257	Brake Cylinder Bracket for upright mounted Winch with Brake Cylinder at the left when facing motor, or for inverted Winch with Brake Cylinder at the right when facing motor	HU-721
	for upright mounted Winch with Brake Cylinder at the right when facing motor, or for inverted Winch with Brake Cylinder at the left when facing motor.	HU-729
258	Brake Cylinder Bracket Cap Screw (2)	HU-723
259	Brake Cylinder Bracket Pin	HU-870
260	Brake Cylinder Bracket Pin Cotter (2)	D02-524
261	Brake Spring (2).	HU-726
262	Yoke Pin	22-720
263	Yoke Pin Cotter.	D02-330
264	Automatic Brake Lever.	HU-718
265	Brake Pipe for Size HU or H5U (43" long)	HU-401
	for Size HUL or H5UL (51" long)	HUL-401
266	Brake Pipe Elbow (2).	D10-400
267	Brake Pipe Strap (2)	HU-727
268	Strap Screw (2)	J-376
269	1/4" Lock Washer (2)	L01-67
270	Brake Stop.	HU-143
271	Brake Stop Set Screw.	R4SM-574
272	1/2" Lock Washer.	D10-322
273	Automatic Brake Reverse Valve for Size HU or HUL	HU-744
	for Size H5U or H5UL	H5U-744
*	Reverse Valve O-ring for Size HU or HUL	AF160-294
	for Size H5U or H5UL	ROB2J73-359
274	Motor Mounting Bracket for inverted mounted Size H5U or H5UL	H5UEC-502
	for all others.	H5U-502
	Brake Exhaust Valve Assembly	HU-A733
280	Brake Exhaust Valve	HU-733
281	Exhaust Valve Elbow.	HU-745
282	Air Strainer Assembly	ROB2-A565
283	Brake Connection.	DU-711
283A	Brake Elbow.	D10-400
284	1/4" Pipe Plug.	ROH-377
285	Orifice Plug	HU-732
286	Exhaust Valve Pipe	HU-731
287	Exhaust Valve Cap Screw (2)	R55H-473
288	5/16" Lock Washer (2).	T11-58

* Not illustrated.

‡ Refer to paragraph 2 of DISENGAGING CLUTCH PARTS on page 10.

PULL CHAIN THROTTLE

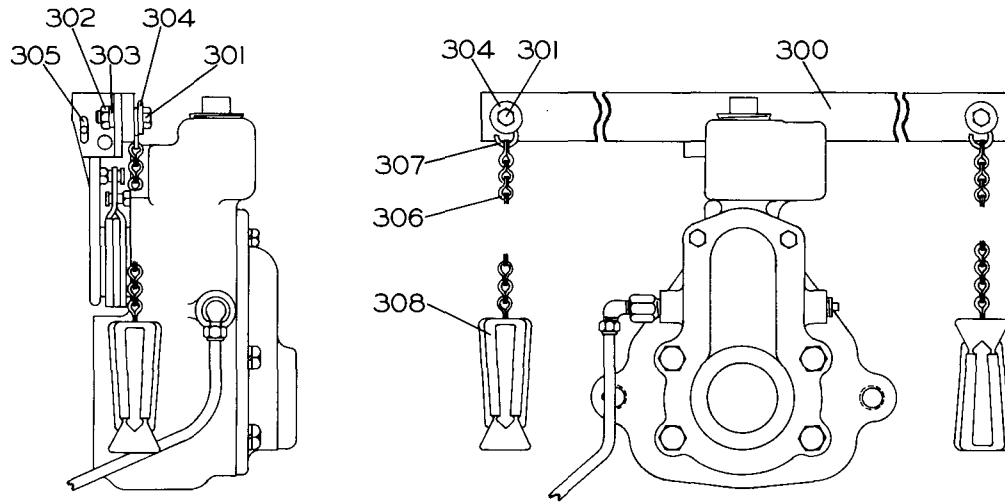

PART NUMBER FOR ORDERING

300	Pull Chain Throttle Lever	HU-559
301	Throttle Chain Bolt (2)	D02-312
302	Throttle Chain Bolt Nut (2)	D02-418
303	3/8" Lock Washer (2)	D02-321
304	3/8" Plain Washer (2)	D02-419
305	Throttle Lever Cotter (1/4" x 1-3/4")	215-124
306	Throttle Lever Chain (2) (length as specified)	DU-413
307	S-Hook (4)	D01-221
308	Throttle Handle (2)	MR-415

AIR STRAINER

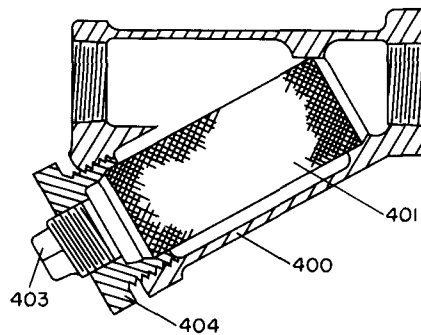

PART NUMBER FOR ORDERING

		↓	↓
		HU, HUL	H5U, H5UL
400	Air Strainer Assembly	HU-A267AT	K4U-A267AT
401	Air Strainer Screen	HU-61AT	K4U-61AT
403	Air Strainer Plug	D02-351	22SR-165
404	Air Strainer Cap	HU-268AT	K4U-268AT
*	Air Strainer Nipple		
	1" x 2"	HHM-286	-----
	1-1/4" x 2-1/2"	-----	KKM-286

* Not illustrated.

WIRE ROPE AND FITTINGS

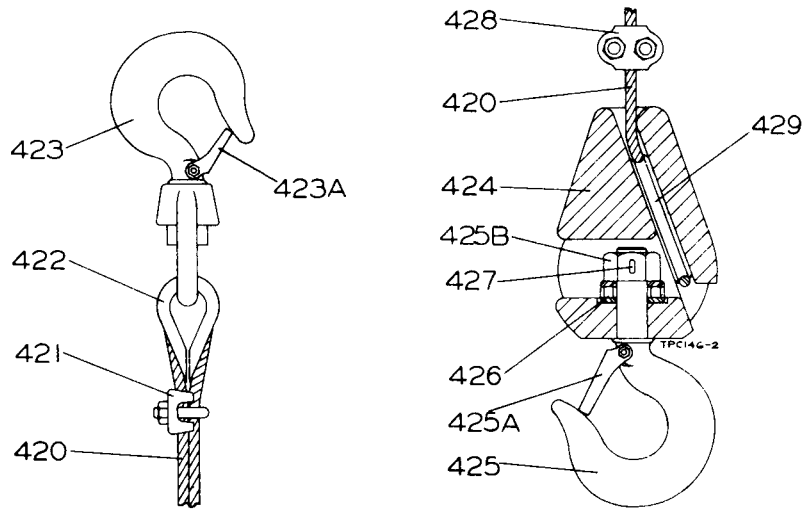

PART NUMBER FOR ORDERING

		↓	↓
		For Use With 3/8" Dia. Wire Rope	For Use With 1/2" Dia. Wire Rope
420	Wire Rope (specify length)	EU-372	215-372
	Wire Rope Fitting Assembly	EU-AS601	K4U-AS601-1/2
421	Wire Rope Clamp (3)	D04-464	D20-375
422	Rope Thimble	D10-721	215-602
423	Swivel Hook	D01C-S377	K4U-S601
	Hook Latch Kit (individual parts not sold separately)	D01-S4055	D02-S4055
	Hook Block Assembly	D02-AS463A	D04-AS463A
424	Hook Block	D02-463A	D04-463A
425	Hook Assembly	D02-AS377	D04-AS377
425A	Hook Latch Kit (individual parts not sold separately)	D02-S123	D04-S123
425B	Nut	D02-305B	HRA60A-305
426	Bearing	D02-379A	D04-379A
427	Roll Pin	20QDM-330	D02-374
428	Rope Clamp	D04-464	D20-375
429	Rope Wedge	D02-373	D02-373

COLUMN CLAMP (For Size HU)

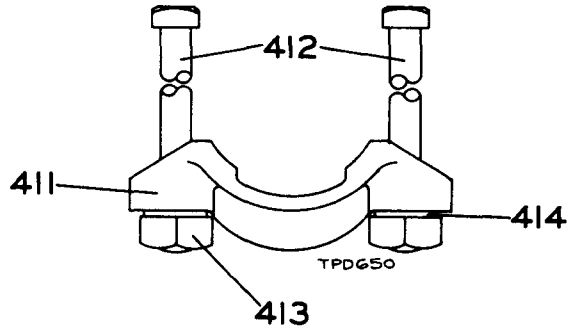

PART NUMBER FOR ORDERING

	Column Clamp Assembly (2)	HU-A657
411	Column Clamp (1 for each Assembly)	DU-657
412	Column Clamp Bolt (2 for each Assembly)	HU-658
413	Column Clamp Bolt Nut (1 for each Bolt)	DU-659
414	Column Clamp Bolt Lock Washer (1 for each Bolt)	21-748

MUFFLER

PART NUMBER FOR ORDERING

	Muffler	KU-674
†	Muffler Nipple	KKM-286
†	Reducing Coupling	HU-677

† Not required for Size H5U or H5UL except when Winch is equipped for Remote Control.

MAINTENANCE TOOLS

TOOL NUMBER FOR ORDERING	TOOL NAME FOR ORDERING	OPERATION
P25-228 D02-426	Grease Gun Rope Set Screw Wrench	Lubrication. Removing or applying the Wire Rope Set Screw (68) in the Rope Drum (67).
HU-932 HU-933	Valve Chest Jack Bolt (2 required) Piston Ring Compressor	Removing the Valve Chest (10 or 230) from the Motor Case (1). Compressing the Piston Rings (50 and 51) when installing the Cylinder (48).
23470	Throttle Valve Stem Reamer	Reaming the throttle valve stem hole in the Reverse Valve Bushing (13 or 208) after installing a new Bushing.
25670	Throttle Valve Seat Reamer (for Size H5U or HSUL)	Refacing the seat for the Poppet Throttle Valve (20 or 216) in the Valve Chest (10 or 204).
25673	Throttle Valve Seat Reamer (for Size HU or HUL)	Refacing the seat for the Poppet Throttle Valve (20 or 216) in the Valve Chest (10 or 204).

●Atlanta, Ga.
111 Ingersoll-Rand Drive
Chamblee, Georgia 30341

★Baton Rouge, La. 70816
4252 Rhoda Drive

★Birmingham, Ala. 35233
1308 4th Ave. South

★Boston, Mass.
2 Kuniholm Dr.
Holliston, Mass. 01746

●Charlotte, N. C. 28208
4840 Wilmont Rd.

★Chattanooga, Tenn. 37408
1936 Central Ave.

●Chicago, Ill.
888 Industrial Drive
Elmhurst, Illinois 60126

★Cleveland, Ohio 44125
9257 Midwest Ave.

●Dallas, Texas 75247
8901 Directors Row

★Denver, Colo. 80207
5805 E. 39th Ave.

●Detroit, Mich.
22122 Telegraph Road
Southfield, Mich. 48075

Ingersoll-Rand

Tool & Hoist Division
28 Kennedy Blvd.
East Brunswick, N. J. 08816

★Freeport, Texas 77541
211 Park Place

●Hartford, Conn.
60 Progress Drive
Manchester, Conn. 06040

●Houston, Texas 77001
6800 Sands Point, P.O. 1455

★Indianapolis, Ind. 46268
5315 West 86th St.

●Los Angeles, Calif. 90022
5533 East Olympic Blvd.

●Milwaukee, Wis.
N84 W13540 Leon Rd.
Menomonee Falls, Wis.
53051

★Minneapolis, Minn. 55404
Corner Franklin & Cedar

★Newark, N. J.
28 Kennedy Blvd.
East Brunswick, N. J. 08816

●New Orleans, La. 70005
939 Lake Ave. Metairie

★Norfolk, Va.
1431C Air Rail Ave.
Virginia Beach, Va. 23455

●Philadelphia, Pa.
651 Park Ave.
King of Prussia, Pa. 19406

●Pittsburgh, Pa. 15220
6 Parkway Ctr.

★Portland, Oregon 97214
240 S. E. Clay St.

★San Francisco, Calif.
14299 Wicks Blvd.
San Leandro, Calif. 94577

●Seattle, Wash. 98188
345 Andover Park East

★Shreveport, La. 71106
454 W. 61st St.

★Syracuse, N. Y. 13208
505 Factory Ave

●St. Louis, Mo. 63132
1515 Page Industrial Blvd.

★Tampa, Fla. 33609
3316 South Westshore Blvd.

Washington, D. C. 20006
1666 K St. N.W.

● Branch and All-Star Servicenter.
★ All-Star Servicenter only.

CANADA

Calgary, Alberta, T2R 0E1
611 11th Ave., S. W.

Montreal, Quebec
620 Cathcart St., H3B 1M2
P.O. Box 1148, H3B 3K9

●Sherbrooke, Quebec
375 Courcolette St., J1H 3X4
Box 1500, J1H 5M3

Sudbury, Ontario, P3A 3T3
P.O. Box 2220

Ingersoll-Rand Canada Inc.
Montreal, Quebec, H3B 1S6
630 Dorchester Blvd. West

●Toronto
Don Mills, Ontario M3B 2V1
255 Lesmill Road

●Vancouver
British Columbia, V6A 2W7
1695 Main St.

Winnipeg, Manitoba, R3H 0M6
1234 Border St.

● All-Star Servicenter.

AUTONOMOUS COMPANIES

Argentina, Buenos Aires
Ingersoll-Rand Argentina
S.A.I.y C
Casilla Correo 2412, Correo Central

Australia, South Melbourne
Ingersoll-Rand (Australia) Ltd.
P.O. Box 219
42 Moray Street, 3205 Victoria

Austria A 1120, Vienna
Ingersoll-Rand Ges M B H
Schoenbrunnerstrasse 213-215/2/5

Belgium, Diegem (Brussels)
Ingersoll-Rand Benelux S.A.
Kouterveldstraat 10-12, 1920 Diegem

Brazil, Sao Bernardo
Ingersoll-Rand S.A. Ind. e Com.
Caixa Postal 911

Chile, Santiago
Ingersoll-Rand Chile
Morande 341
Casilla 126-D

Colombia, Bogota
Macquinarias Ingersoll-Rand
de Colombia, S.A.
Apartado Aero 7451

Denmark, Albertslund DK2620
Ingersoll-Rand AB
Herstedvang 11

Egypt, Cairo
Ingersoll-Rand North East Africa
P.O. Box 820
23A Ismail Mohamed St.
Zamalek

England, London, SW1X, 7LJ
Ingersoll-Rand Co., Ltd.
Bowater House, Knightsbridge

France, 78 190 Trappes Yvelines
Compagnie Ingersoll-Rand
Avenue Albert Einstein
Zone Industrielle

Germany, 403 Ratingen
Ingersoll-Rand GmbH
Robt. Zapp Str. 7
Postfach 1380

Greece, Athens 610
Ingersoll-Rand Central Middle East
17th Floor Athens Tower
Mesogion 2-4

Hong Kong
Ingersoll-Rand Far East
19th Floor, Lap Heng House
50, Gloucester Road

India, Bombay 400018
Ingersoll-Rand (India) Private Ltd.
44 Maulana Abdul Gaffar Rd.
P.O. Box 16564, Worli

Iran, Tehran
Ingersoll-Rand Iran
P.O. Box 12-1538

Ireland, Dublin
Ingersoll-Rand Company (Ireland) Ltd
John F. Kennedy Drive
Bluebell

Italy, 20100 Milano
Ingersoll-Rand Italiana, S.p.A.
Strada Provinciale Cassanese
Caselle Postale 1232
Vignate, Italy

Japan, 106 Tokyo
Ingersoll-Rand (Japan) Ltd.
Kowa Bldg. No. 17
2-7 Nishi-Azabu 1-Chome
Minato-Ku

Kenya, Nairobi
Ingersoll-Rand Mid Africa
P.O. Box 14240

Malaysia, Petaling Jaya
Ingersoll-Rand Malaysia, Sdn. Bhd.
P.O. Box No. 125

Mexico, 10 D.F. Mexico
Ingersoll-Rand S.A. de C.V.
Apartado 41-666

Netherlands, Zoeterwoude
Ingersoll-Rand Benelux N.V.
P.O. Box 33, Zoeterwoude

Norway, Oslo 1
Ingersoll-Rand AB
P.O. Box 143-Sentrum

Peru, Lima
Ingersoll-Rand Co. of Peru, S.A.
Casilla 2261

Philippines, Makati, Rizal 3117
Ingersoll-Rand Philippines, Inc.
P.O. Box 445 MCC

Portugal, Lisbon 5
Ingersoll-Rand Lda
Apartado 2933

Puerto Rico, San Juan 00936
Ingersoll-Rand de Puerto Rico Inc.
G.P.O. Box 1222

Singapore 22
Ingersoll-Rand Southeast Asia (Pte.) Ltd
G.P.O. Box 2062, Singapore 1

South Africa, Alberton
Ingersoll-Rand Co. S.A. (Proprietary) Ltd
P.O. Box 3720
Atrode, 1451

Spain, Madrid
Cia. Ingersoll-Rand, S.A.
Apartado 518

Sweden, Bromma
Ingersoll-Rand A B
Fack
S-16125 Bromma 1

Venezuela, Caracas
Ingersoll-Rand de Venezuela S.A.
Apartado 70588, Los Ruices

AUTHORIZED I-R SALES AND SERVICE

Distributors in principal cities throughout the world. Contact the nearest Ingersoll-Rand office for the name and address of the distributor in your country or write to Ingersoll-Rand International, Woodcliff Lake, New Jersey.