

## IMPORTANT INFORMATION:

- A copy of our “Safe Operating Practices” Manuals are always available free of charge either by downloading it from our Technical Publications website @ [www.airwinch.com](http://www.airwinch.com) or by contacting the Factory at (800) 866-5457 for North America and (206) 624-0466 for International. The Safe Operating Practices manual must be read prior to anyone operating a **Ingersoll-Rand** winch or hoist. The manual form numbers are as follows:

“Safe Operating Practices Non-Man Rider™ Winches” Manual, Form No. MHD56250

“Safe Operating Practices for Man Rider™ Winches” Manual, Form No. MHD56251

“Safe Operating Practices for Pneumatic, Hydraulic and Electric Hoists” Manual, Form No. MHD56295

- Available winch options may require additional supplements to the basic winch manual.
- For Man Rider™ winches ensure a copy of the Man Rider™ supplement is made available to the operator prior to winch operation.

### Winch Man Rider™ Supplements:

Model:	Publication No.
FA2, FA2.5, FH2, FH2.5	MHD56046
FA5	MHD56042 and MHD56220
FA10	MHD56252
FA2.5A	MHD56236
FA2B and HU40A	MHD56207
FH10MR	MHD56212
Fulcrum Electric	MHD56277
LS500HLP/ LS1000HLP	SAM0004

Model:	Publication No.
LS500RLP	SAM0011
LS1000RLP	SAM0012
LS150RLP	SAM0082
LS150RLP/500/ 1000	SAM0115
LS150RLP and LS150PLP-PH	SAM0120
LS500RLP-E	SAM0122
LS150RLP- DP5M-F	SAM0184
LS150HLP	SAM0222

- We strongly recommend that ALL maintenance on **Ingersoll-Rand** equipment be carried out by personnel certified by **Ingersoll-Rand**, or by **Ingersoll-Rand** Authorized Service Centers.
- Contact the Factory if in doubt about installation, operation, inspection and maintenance instructions.
- Use only Genuine **Ingersoll-Rand** parts when maintaining or repairing a winch, hoist or any component of a winch or hoist.
- ANSI / ASME recommends that a winch or hoist (or any components of a winch or hoist) that has been repaired be tested prior to being placed into service:
  - \* **Winches** - ANSI / ASME B30.7 (BASE MOUNTED DRUM HOISTS) Refer to section 7.2.2 - Testing.
  - \* **Hoists** - ANSI / ASME B30.16 (OVERHEAD HOISTS - UNDERHUNG) Refer to section 16.2.2 - Testing.

# PARTS, OPERATION AND MAINTENANCE MANUAL for **Hercu-Link™ AIR HOIST** MODELS

**HA1-005**  
5 ton

**HA1-010**  
10 ton

**HA1-015**  
15 ton

**HA1-020**  
20 ton

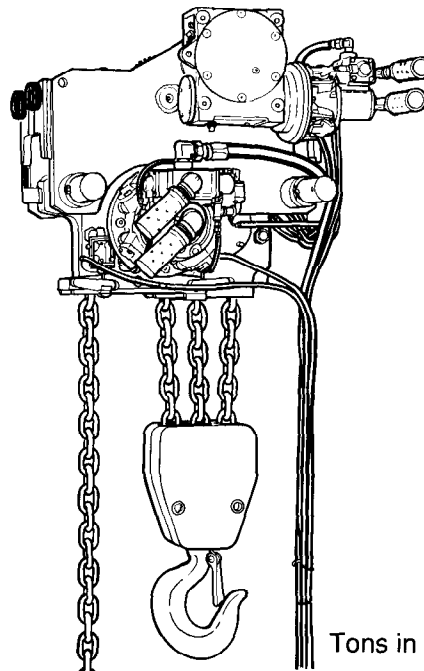

Tons in this manual are metric tons (2,200 lbs.)

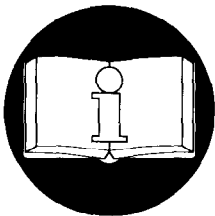

**READ THIS MANUAL BEFORE USING THESE HOISTS.** This manual contains important safety, installation, operation and maintenance information. Make this manual available to all persons responsible for the operation, installation and maintenance of these products.

## **⚠ WARNING**

**Do not use this hoist for lifting, supporting or transporting people or lifting or supporting loads over people.**

**Always operate, inspect and maintain this hoist in accordance with American National Standards Institute Safety Code (ASME B30.16) and any other applicable safety codes and regulations.**

**Refer all communications to the nearest Ingersoll-Rand Material Handling Products Office or Distributor.**

Form MHD56075  
Edition 1  
September 1993  
71123053

© 1993 Ingersoll-Rand Company

**INGERSOLL-RAND®**  
**MATERIAL HANDLING**

# TABLE OF CONTENTS

Description	Page No.
<b>Safety Information</b>	
Danger, Caution, Warning and Notice .....	3
Safe Operating Instructions .....	4
Warning Labels and Tags .....	5
<b>Specifications</b>	
Description of Hoist Operation .....	6
Specification Chart .....	6
Model Code Explanation .....	7
<b>Installation</b>	
Hoist and Trolley Installation .....	8
Air Supply .....	9
Motor .....	10
Initial Operating Checks .....	11
Air Schematics .....	12
<b>Operation</b>	
Hoist Controls .....	13
<b>Inspection</b>	
Records and Reports .....	15
Frequent Inspection .....	15
Periodic Inspection .....	16
Hoists not in Regular Use .....	17
Inspection and Maintenance Report .....	18
<b>Lubrication</b>	
Motor .....	19
Load Chain .....	20
Reduction Gear Assembly .....	21
<b>Troubleshooting</b>	
Troubleshooting Chart .....	22
<b>Maintenance</b>	
Maintenance Intervals .....	24
Load Chain Replacement .....	24
Hoist Disassembly .....	27
Cleaning, Inspection and Repair .....	30
Hoist Assembly .....	31
Load Test .....	36
Index of Exploded View Parts Illustrations .....	39
Hoist Parts Section .....	40
<b>Parts Ordering Information</b>	
Return Goods Policy .....	78
Warranty .....	79

## SAFETY INFORMATION

This manual provides important information for all personnel involved with the safe installation, operation and proper maintenance of this product. Even if you feel you are familiar with this or similar equipment, you should read and understand this manual before operating the product.

### Danger, Warning, Caution and Notice

Throughout this manual there are steps and procedures which, if not followed, may result in a injury. The following signal words are used to identify the level of potential hazard.

**⚠ DANGER** Danger is used to indicate the presence of a hazard which *will* cause *severe* injury, death, or substantial property damage if the warning is ignored.

**⚠ WARNING** Warning is used to indicate the presence of a hazard which *can* cause *severe* injury, death, or substantial property damage if the warning is ignored.

**⚠ CAUTION** Caution is used to indicate the presence of a hazard which *will* or *can* cause *minor* injury or property damage if the warning is ignored.

**NOTICE** Notice is used to notify people of installation, operation, or maintenance information which is important but not hazard-related.

### Safety Summary

#### ⚠ WARNING

- Do not use this hoist for lifting, supporting, or transporting people or lifting or supporting loads over people.
- Air powered hoists are designed to provide a 5 to 1 safety factor and are factory tested to 125% of the rated load. The supporting structures and load-attaching devices used in conjunction with this hoist must provide adequate support to handle all hoist operations plus the weight of the hoist and attached equipment. This is the customer's responsibility. If in doubt, consult a registered structural engineer.

#### NOTICE

- Lifting equipment is subject to different regulations in each country. These regulations may not be specified in this manual.

The National Safety Council, Accident Prevention Manual for Industrial Operations, Eighth Edition and other recognized safety sources make a common point: Employees who work near cranes or assist in hooking on or arranging a load should be instructed to keep out from under the load. From a safety standpoint, one factor is paramount: conduct all lifting operations in such a manner that if there were an equipment failure, no personnel would be injured. This means keep out from under a raised load and keep out of the line of force of any load.

**Ingersoll-Rand** Material Handling hoists are manufactured in accordance with the latest ASME B30.16 standards.

The Occupational Safety and Health Act of 1970 generally places the burden of compliance with the owner/employer, not the manufacturer. Many OSHA requirements are not concerned or connected with the manufactured product but are, rather, connected with the final installation. It is the owner's responsibility and user's responsibility to determine the suitability of a product for any particular use. It is recommended that all applicable industry, trade association, federal, state and local regulations be checked. Read all operating instructions and warnings before operation.

**Rigging:** It is the responsibility of the operator to exercise caution, use common sense and be familiar with proper rigging techniques. See ASME B30.9 for rigging information, American National Standards Institute, 1430 Broadway, New York, NY 10018.

This manual has been produced by **Ingersoll-Rand** to provide dealers, mechanics, operators and company personnel with the information required to install, operate, maintain and repair the products described herein.

It is extremely important that mechanics and operators be familiar with the servicing procedures of these products, or like or similar products, and are physically capable of conducting the procedures. These personnel shall have a general working knowledge that includes:

1. Proper and safe use and application of mechanics common hand tools as well as special **Ingersoll-Rand** or recommended tools.
2. Safety procedures, precautions and work habits established by accepted industry standards.

**Ingersoll-Rand** can not know of, nor provide all the procedures by which product operations or repairs may be conducted and the hazards and/or results of each method. If operation or maintenance procedures not specifically recommended by the manufacturer are conducted, it must be ensured that product safety is not endangered by the actions taken. If unsure of an operation or maintenance procedure or step, personnel should place the product in a safe condition and contact supervisors and/or the factory for technical assistance.

## SAFE OPERATING INSTRUCTIONS

The following warnings and operating instructions have been adapted in part from American National (Safety) Standard ASME B30.16 and are intended to avoid unsafe operating practices which might lead to injury or property damage.

An operator should be physically competent. The operator should have no health condition which might affect his ability to react, and he should understand the operation of the hoist, including reading the manufacturer's literature. The operator should have a working knowledge of hitching loads. The operator should have a good attitude regarding safety and should refuse to operate the hoist under unsafe conditions.

**Ingersoll-Rand** recognizes that most companies who use hoists have a safety program in force at their facility. If you are aware that some conflict exists between a rule set forth in this publication and a similar rule already set by an individual company, the more stringent of the two should take precedence.

Safe Operating Instructions are provided to make an operator aware of dangerous practices to avoid and are not necessarily limited to the following list. Refer to specific sections in the manual for additional safety information.

1. Only allow personnel trained in, safety and operation on this product to operate and maintain the hoist.
2. Only operate a hoist if you are physically fit to do so.
3. When a "DO NOT OPERATE" sign is placed on the hoist controls, do not operate the hoist until the sign has been removed by designated personnel.
4. Before each shift, the operator should check the hoist for wear or damage.
5. Never use a hoist which inspection indicates is worn or damaged.
6. Do not use hoist if hook latch on a hook has been sprung or broken.
7. Check that the hook latches are engaged before using.
8. Never splice a hoist chain by inserting a bolt between links.
9. Only lift loads less than or equal to the rated capacity of the hoist. See warning labels attached to the hoist.
10. When using two hoists to suspend one load, select two hoists each having a rated capacity equal to or more than the load. This provides adequate safety in the event of a sudden load shift.
11. Never place your hand inside the throat area of a hook.
12. Never use the hoist chain as a sling.
13. Only operate a hoist when the load chain is centered over the hook. Do not "side pull" or "yard".
14. Never operate a hoist with twisted, kinked, "capsized" or damaged load chain.
15. Do not force a chain or hook into place by hammering.
16. Never insert the point of the hook into a chain link.
17. Be certain the load is properly seated in the saddle of the hook.
18. Do not support the load on the tip of the hook.
19. Never run the load chain over a sharp edge. Use a sheave.
20. Pay attention to the load at all times when operating the hoist.
21. Make sure all people are clear of the load path. Do not lift a load over people.
22. Never use the hoist for lifting or lowering people, and never allow anyone to stand on a suspended load.
23. Ease the slack out of the chain and sling when starting a lift. Do not jerk the load.
24. Do not swing a suspended load.
25. Never suspend a load for an extended period of time.
26. Never leave a suspended load unattended.
27. Never weld or cut a load suspended by the hoist.
28. Never use the hoist chain as a welding electrode.
29. Do not operate hoist if chain jumping, excessive noise, jamming, overloading, or binding occurs.
30. Keep the load from hitting the load chain.
31. Do not use the up and down emergency stop limit protection as a normal means of stopping the hoist.
32. Avoid unnecessary jogging of hoist and/or trolley controls.
33. Always rig the hoist properly and carefully.
34. Shut off air supply before performing any maintenance.
35. Avoid collision or bumping of hoist.
36. After use, properly secure hoist and all loads.

## WARNING LABELS AND TAGS

Each hoist is supplied from the factory with the warning tags and labels shown. If the tags or labels are not attached to your hoist, order new tags or labels and install them. See Labels and Tags parts list in parts section. Read and obey all warnings and other safety information attached to this hoist. Tags and labels may not be shown actual size.

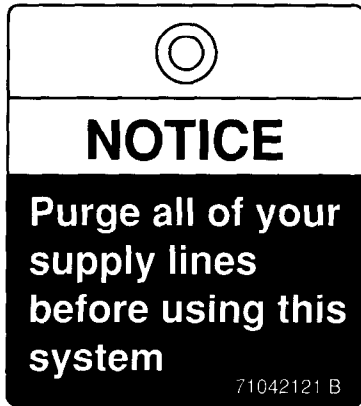

Tag part number 71042121/B is attached to the inlet air supply components.

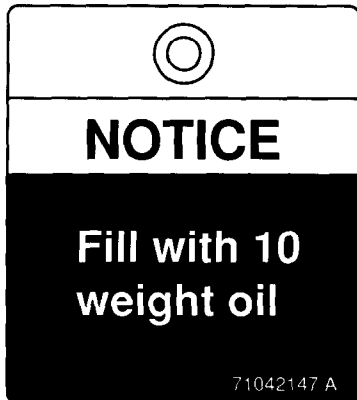

Tag part number 71042147/A is attached to the lubricator in the inlet air supply line .

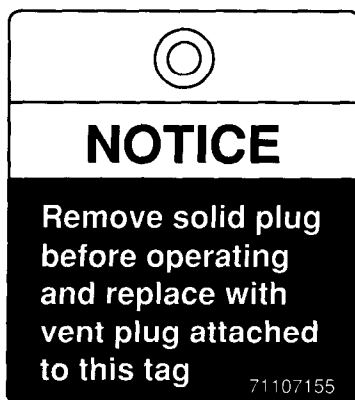

Tag part number 71107155 is attached to the power head reduction gear assembly fill plug.



Tag part number 71059612/B is attached to the pendant assembly.



Tag part number 71107148 is attached to the power head reduction gear assembly.



Label part number 71107130/A is attached to the inlet air supply components.

## SPECIFICATIONS

### Description of Hoist Operation

The HA1 air powered hoist primarily consists of a power head assembly which acts as the control for the lower hook block movement. The power head assembly is made up of three main sections. They are the motor and first gear reducer section, the brake and second gear reducer section and the sheave section.

The output shaft from the piston motor is connected to the first planetary reducer assembly. The output from the first planetary reducer assembly is connected to the brake by the input shaft which passes through the center of the sheave section. The input shaft also acts as the sun gear for the second stage planetary reducer. The output from the secondary planetary reduction assembly is transmitted directly to the load chain sheave.

The input shaft cannot rotate in either direction until the brake has been released. The brake is released by air pressure applied to the annular brake piston. The piston compresses the brake springs, releasing the brake discs. There are five sintered bronze type brake friction discs and six stationary brake discs.

The brake piston is actuated by air from the main control valve. When the control pendant "UP" or "DOWN" button is pushed it moves the main control valve spool. The spool is designed to send air to the brake.

When the pendant "UP" or "DOWN" button is released, quick exhaust valves allow the brake to set quickly and avoid downward load drift.

**Table 1**

Model No.	Capacity (metric tons)	Std. Lift		Speed				HP	Air Supply	
		ft	m	Lift (fpm)	Lift (m/min)	Lower (fpm)	Lower (m/min)		cfm	cu.m/min
HA1-005	5	10	3	10	3	15	4.6	3.8	165	4.67
HA1-010	10	10	3	5	1.5	7-1/2	2.3	3.8	165	4.67
HA1-015	15	10	3	3-1/4	1	5	1.5	3.8	165	4.67
HA1-020	20	10	3	2-1/2	0.76	3-3/4	1.14	3.8	165	4.67

**Table 2**

Model No.	Capacity (metric tons)	Load Chain Size (mm)	Head Room*				Unit Weight Hook Mount		Unit Weight with Trolley (Piston Motor)	
			Hook Mount		Trolley Mount		lbs	kg	lbs	kg
			in	mm	in	mm				
HA1-005	5	16	27-5/8	702	23-9/16	598	685	311	905	411
HA1-010	10	16	35-1/2	902	30-1/2	775	765	348	1105	502
HA1-015	15	16	41-7/8	1064	35-1/4	895	875	398	1315	590
HA1-020	20	16	42-1/2	1080	34-9/16	878	975	443	1425	640

\* Head room dimensions are for hoists without limit switches. Refer to sales brochure for head room dimensions of hoists with limit switches.

# Model Code Explanation

## Model Code Example

**HA1 - 010M - A3 - 30 - 27FLM**

<b>Series</b>	HA = Hercu-Link Air Powered Hoist			
<b>Frame Size</b>	1 = 16 mm Load chain			
<b>Capacity</b>	005 = 5 metric ton (11,000 lbs) 010 = 10 metric ton (22,000 lbs) 015 = 15 metric ton (33,000 lbs) 020 = 20 metric ton (44,000 lbs)			
<b>Suspension</b>	H = Hook mount C = Clevis mount* D = Deck Mount* P = Plain trolley G = Geared trolley V = Vane motor driven trolley M = Piston motor driven trolley			
<b>Trolley Flange Adjustment</b>	M = No trolley used with hook A = Standard B = 2 in. (51 mm) extension C = 4 in. (102 mm) extension D = 6 in. (152 mm) extension			
<b>Control</b>	1 = Pull rope		5 = 1 motor with emergency stop	
	2 = 1 motor pendant (2 button)		6 = 2 motor with emergency stop	
	3 = 2 motor pendant (4 button)		7 = 3 motor with emergency stop	
	4 = 3 motor pendant (6 button)			
<b>Lift</b>	XX = Length of lift. (XX = Specify length (ft). Max. 60 ft. (18 m))			
<b>Control Drop</b>	XX = Control Drop Pendant or Hand chain length			
<b>Options</b>	C = Corrosion resistant coating (SBCZ and Marine 812 top coat) L = Upper and lower limit switch N = Corrosion resistant load chain (zinc plated) M = Marine protection package T = Galvanized chain container (not available on 5 ton hook mounted models) Y = Hull bumper (for hook mounted shipyard hoists only) R = Copper plate S•COR•E package S = Solid bronze S•COR•E package (12-1/2 ton models only) Q = 60 psi application package			
<b>Trolley</b>	B = Trolley bumper G = Trolley guide rollers			
<b>Control</b>	F = Push button main air shutoff A = Accu-Trol® pendant			

\* Features not covered in this manual. For additional information contact your nearest **Ingersoll-Rand** Material Handling office or distributor.



## INSTALLATION

Prior to installing the hoist, carefully inspect it for possible shipping damage.

### WARNING

- Before installing hoist read "SAFETY INFORMATION" section.

Hoists are supplied from the factory with the correct grade and quantity of lubricating oil. Before operation all oil levels must be checked and/or topped off with the proper type of oil recommended in the "LUBRICATION" section. Lubricate load chain before operating hoist.

### CAUTION

- Owners and users are advised to examine specific, local or other regulations, including American National Standards Institute and/or OSHA Regulations which may apply to a particular type of use of this product before installing or putting hoist to use.

Remove cover from the shipping crate. Carefully remove steel straps. On units equipped with a trolley, carefully position wire rope sling around the hoist trolley side plates and slowly lift hoist assembly. Constantly monitor the position of the hoist and trolley to ensure the load is balanced and secure. On hook mounted units lift into position by using top hook of the hoist. Attach chain container to hoist with chain container pin and connect the container suspension hook as required.

### Hook Mounted Hoist Installation

Place hook over mounting structure. Make sure hook latch is engaged. Ensure the supporting member rests completely within the saddle of the hook and is centered directly above the hook shank.

### CAUTION

- Do not use a supporting member that tilts to one side or the other.

### Trolley and Hoist Installation

### WARNING

- A falling load can cause injury or death. Before installing trolley and hoist, read "SAFETY INFORMATION".
- Depending on the size of hoist selected it could weigh as much as 1425 lbs. (640 kg). If parts of the trolley or hoist are dropped, they could cause injury or damage property. Adequately support the hoist and trolley when lifting them into place on the beam.

### Installing Over the End of the Beam

Preadjust trolley width for the beam flange measurement. Refer to "Installing from Underneath the Beam." Remove the rail stop and slide trolley on end of the beam. Reinstall rail stop. If this procedure cannot be used, due to insufficient space or fixed limit stops, the trolley must be installed from underneath the beam using the procedure which follows.

### Installing from Underneath the Beam

(Ref. Dwgs. MHTPA0511 and MHTPC0532)

1. Measure beam flange width and compare with measurement between trolley wheel flanges. The correct total clearance between the beam and the trolley wheel flanges is 1/16 to 3/16 in. (2 to 5 mm). To adjust trolley wheel spacing remove cotter pins (178) and pins (177) at side plate. Remove adjusting spacers (157) and side plate and add or subtract an equal number of adjusting spacers (157) on suspension shafts (174) between top frame and side plates. Longer spacers (175) and (176) are used on trolleys which will be mounted to wider beam flange widths. Ensure that the same spacer configuration is used on either side of the hoist top frame.
2. When desired trolley wheel spacing measurement is achieved, carefully position wire rope sling around the hoist trolley side plates and slowly lift hoist and trolley assembly into place beneath the beam flange. Press side plates together on beam. Trolley wheels must rest on top of the beam flange.

### CAUTION

- To avoid an unbalanced load which may damage the trolley, the hoist must be centered under the trolley by the spacers (157).
3. Slide remaining adjusting spacers (157) over the free end of the suspension shafts (174). Insert pins (177) into the holes in the suspension shafts (174). Secure by installing cotter pins (178) and bending ends apart.
  4. The pin (177) and outside spacers (157) must hold the trolley to the adjustment in step 1. If the side plates can be spread farther apart, install more outside spacers (157) between side plate and the pin (177).

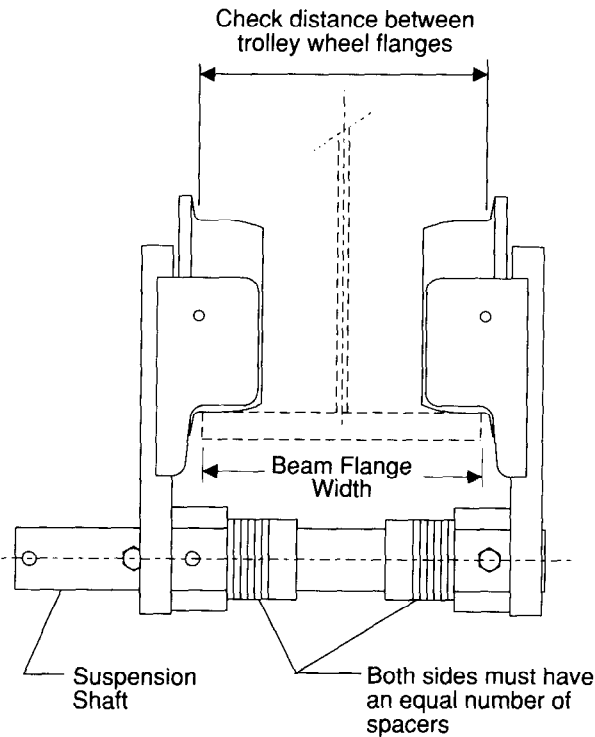

(Dwg. MHTPA0511)

### Trolley Installation

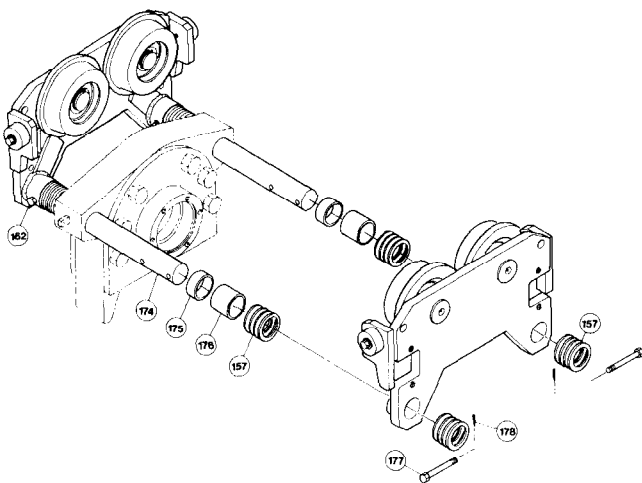

(Dwg. MHTPC0532)

### NOTICE

- Trolley wheels ride on the top of the lower flange of the beam.

5. If trolley is equipped with guide rollers measure beam flange width and compare with measurement between guide rollers. Side roller spacing measurement should be 1/16 to 3/16 in. (2 to 5 mm) greater than beam flange width.
6. Ensure beam stops are installed prior to operating hoist and trolley.
7. Prior to placing into service test the trolley. Check that the trolley side plates are vertical. Raise a load equal to the rated capacity of the hoist 6 to 7 ins. (130 to 180 mm) off the floor and operate the trolley along the entire length of the beam.

### Chain Container (optional feature)

### CAUTION

- Do not pile chain carelessly in the chain container. Piling the chain carelessly into the container by hand may lead to kinking or twisting that will jam the hoist.

1. Check the chain container size to make sure the length of load chain is within the capacity of the chain container. Replace with a larger chain container, if required.
2. Attach chain stopper (241) to the last link of the load chain free end.
3. Attach the chain container to the hoist.
4. Run bottom block to lowest point and run hoist in up direction to feed the chain back into the container.

### NOTICE

- When feeding chain into the chain container begin with the chain stopper end of the chain so that it piles naturally.

### Attaching Free End of Load Chain

1. Install chain stopper (241) on the end of the load chain.
2. Attach the free end of the load chain to the hoist or bottom hook assembly. See Chaining Drawings in the "MAINTENANCE" section.

After installing load chain, make sure it is not twisted or kinked. Fix before using hoist.

### Air Supply

The air supply must be clean and free from moisture. Due to efficiency losses in the air lines and air line components, air pressures should be checked at the hoist motor. A minimum of 105 psi (7.2 bar/724 Kpa) at the hoist motor is required to provide rated hoist capacity. Due to efficiency losses in air lines, pressures of up to 130 psi (8.9 bar/896 Kpa) at the air supply may be required to achieve the required operating pressure. (Contact the Technical Support Department for operating requirements with optional 60 psi system).

## Air Lines

The inside diameter of the hoist air supply lines must not be smaller than 1 in. (25 mm) based on a maximum of 50 ft. (15 m) between the air supply and the hoist. Contact the factory for recommended air line sizes for distances greater than 50 ft. (15 m). Before making final connections, all air supply lines should be purged before connecting to unit inlet. Supply lines should be as short and straight as installation conditions will permit. Long transmission lines and excessive use of fittings, elbows, tees, globe valves etc. cause a reduction in pressure due to restrictions and surface friction in the lines.

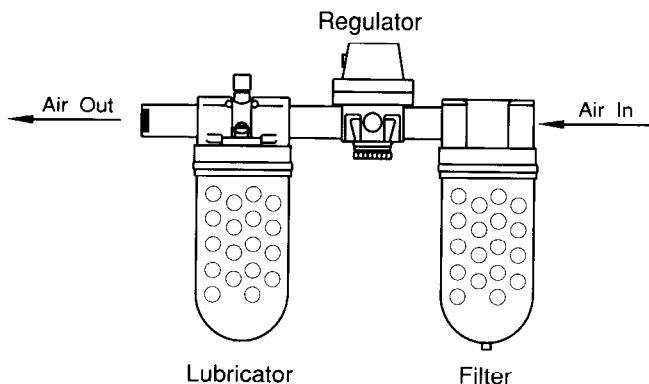

(Dwg. MHTPA0191)

## Air Line Lubricator

(Ref. Dwg. MHTPA0191)

Always use an air line lubricator with these motors. Use a lubricator having an inlet and outlet at least as large as the inlet on the motor. Install the air line lubricator as close to the air inlet on the motor as possible.

## CAUTION

- Lubricator must be located no more than 10 ft. (3 m) from the motor.

The air line lubricator should be replenished daily and set to provide 4 to 6 drops per minute of SAE 10W oil. A fine mist will be exhausted from the throttle control valve when the air line lubricator is functioning properly.

## Air Line Filter

(Ref. Dwg. MHTPA0191)

It is recommended that an air line strainer/filter be installed as close as practical to the motor air inlet port to prevent dirt from entering the motor. The strainer/filter should provide 20 micron filtration and include a moisture trap. Clean the strainer/filter periodically to maintain its operating efficiency.

## Moisture in Air Lines

Moisture that reaches the air motor through the supply lines is the chief factor in determining the length of time between service overhauls. Moisture traps can help to eliminate moisture and other methods, such as an air receiver which collects moisture before it reaches the

motor or an aftercooler at the compressor that cools the air prior to distribution through the supply lines, are also helpful.

## Motor and Reducer Assemblies

Remove shipping 'O' Ring (360) from breather on hoist motor and trolley motor if equipped.

## WARNING

- Failure to remove shipping 'O' Ring(s) on the motor breather(s) may result in premature failure of the motor seals.

## Hoist and Trolley Motors

For optimum performance and maximum durability of parts, provide an air supply to operate hoist and trolley motors with 105 psig at 165 scfm (7.2 bar/724 kpa at 4.67 cu.m/m). The air motor should be installed as near as possible to the compressor or air receiver. (Contact the Technical Support Department for operating requirements with optional 60 psi system)

## Hoist Pendant

The pendant control is installed at the factory. Hose fittings on the pendant are color coded to ensure correct assembly. Check all hose connections are tight and that hoses are not twisted or crimped. Refer to Dwg. MHTPA0095 and MHTPA0510 for correct pendant hose connections. If the optional Accu-trol® pendant is used refer to Accu-trol pendant manual form number MHD56014 for correct pendant hose connections.

## WARNING

- Disconnect air supply before performing any maintenance.
- Do not attempt to reverse air lines either at the pendant station or hoist. This will give a false indication of operation which may result in serious damage to the hoist.

## PENDANT CONTROL BLOCK (Looking Down On Top of Block)

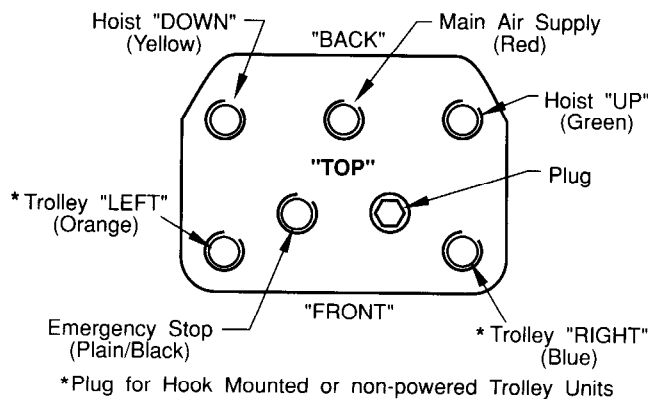

(Dwg. MHTPA0095)

Check strain relief chain (188) is properly connected to the hoist and pendant body. The chain is connected to the hoist at the piston motor assembly with capscrew (631). Ensure pendant is supported by the chain and not hose assemblies.

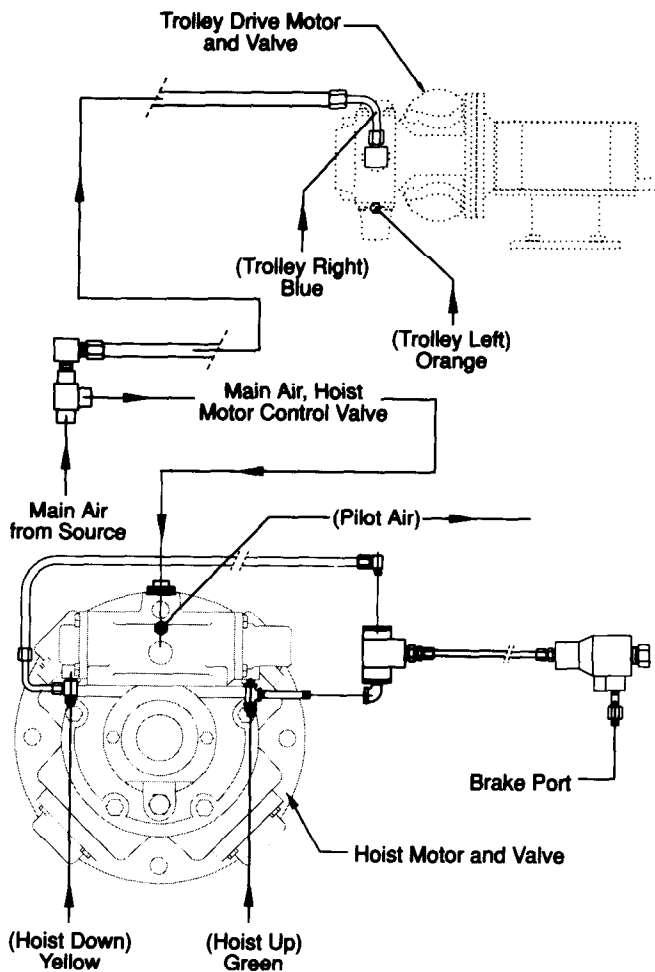

(Dwg. MHTPA0510)

**⚠ CAUTION**

• To avoid damaging the pendant hose, make sure the strain relief chain, not the pendant hoses, is supporting the weight of the pendant.

**Emergency Air Shutoff (optional feature)**

If supply air is wet and unfiltered, and/or the hoist is operated in a dirty environment, the hoist or trolley control valves may malfunction and become stuck "on". As a safeguard, an emergency main line shutoff valve is provided at the pendant. The emergency valve shuts off the air supply to the entire unit when the red pull/push button is depressed (pushed in).

If it is necessary to use the emergency air shut off valve, then the malfunctioning control valve should be disassembled, cleaned, and/or repaired as required to clear the malfunction before resuming operation.

**Initial Operating Checks**

Hoists are tested for proper operation prior to leaving the factory. Before the hoist is placed into service the following initial operating checks should be performed.

1. After installation of trolley mounted hoists, check to ensure the hoist is centered below the trolley.
2. Check for air leaks in the supply hose and fittings to pendant, and from pendant to manifold.
3. When first running the hoist or trolley motors some light oil should be injected into the inlet connection to allow good lubrication.
4. When first operating the hoist and trolley it is recommended that the motors be driven slowly in both directions for a few minutes.
5. Operate the trolley along the entire length of the beam.
6. Inspect hoist and trolley performance when raising, moving and lowering test load(s). Hoist and trolley must operate smoothly and at rated specifications prior to being placed in service.
7. Check that trolley (if equipped) and hook movement is the same direction as arrows or information on the pendant control.
8. Raise and lower a light load to check operation of the hoist brake.
9. Check hoist operation by raising and lowering a load equal to the rated capacity of the hoist a few inches (cm) off the floor.
10. Check operation of limit devices.
11. On trolley units check 'O' ring (360) on breather plug (362) in trolley drive piston motor has been removed.

**Storing the Hoist**

For hoists that have been in storage for a period of more than one month the following start-up procedure is required.

1. Give the hoist an inspection conforming to the requirements of "Hoists Not in Regular Use" in the "INSPECTION" section.
2. Pour a small amount of 10W oil in the motor inlet port(s).
3. Operate the motor for 10 seconds to flush out any impurities.
4. The hoist is now ready to work.

**Trolley Drive Assembly Run In Period**

Maximum efficiency of the trolley drive worm gear is obtained after a "run-in" period. The length of time required will depend on the load applied and will be two to four hours at rated load and considerably longer at lighter loads. (Overloading will not decrease the "run-in" time and it may damage the worm gear.)

During "run-in" higher than normal temperature rise, and lower efficiency and output torque can be expected.

# AIR SCHEMATICS

**Hoist without air powered trolley.**

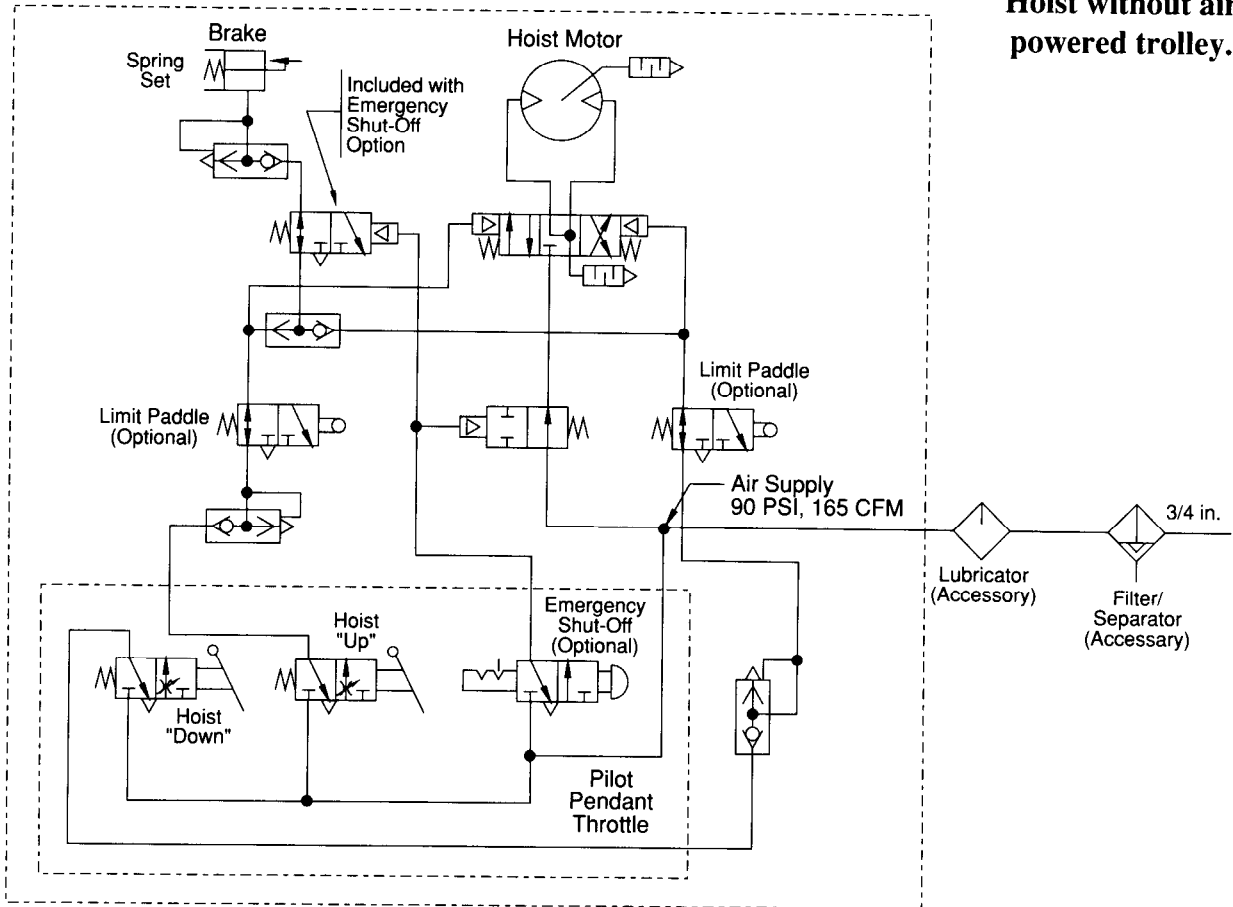

(Dwg. MHTPA0534)

**Hoist with air powered vane or piston motor trolley.**

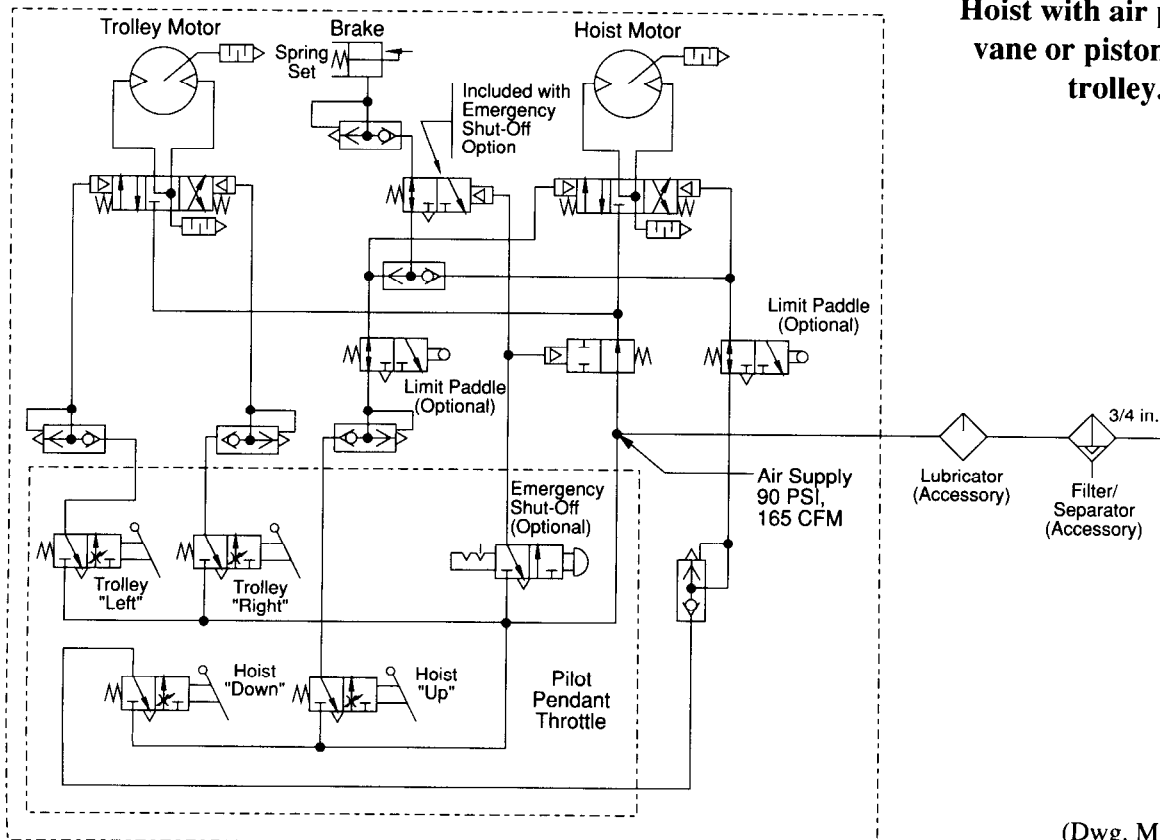

(Dwg. MHTPA0535)

## OPERATION

The four most important aspects of hoist operation are:

1. Follow all safety instructions when operating the hoist and trolley.
2. Allow only people instructed in safety and operation of this product to operate the hoist and trolley.
3. Subject each hoist to a regular inspection and maintenance procedure.
4. Be aware of the hoist capacity and weight of load at all times.

### **⚠ WARNING**

- Only allow personnel instructed in safety and operation of this product to operate the hoist and trolley.
- The hoist is not designed or suitable for lifting, lowering or moving persons. Never lift loads over people.

Operators must be physically competent. Operators must have no health condition which might affect their ability to act, and they must have good hearing, vision and depth perception. The hoist operator must be carefully instructed in his duties and must understand the operation of the hoist, including a study of the manufacturer's literature. The operator must thoroughly understand proper methods of hitching loads and should have a good attitude regarding safety. It is the operator's responsibility to refuse to operate the hoist under unsafe conditions.

### Initial Operating Checks

Hoists are tested for proper operation prior to leaving the factory. Before the hoist is placed into service perform the initial operating checks described in the "INSTALLATION" section.

### Hoist Controls

Refer to Dwg. MHTPA0094 and MHTPA0095 in the "INSTALLATION" section for correct pendant hose connections.

### Pilot Pendant Throttle with Emergency Stop

(Ref. Dwg. MHTPA0395)

The pendant control throttle is equipped with two separate levers for hoist operation. Pilot pressure from the pendant throttle activates the hoist control valve. Direction of hook travel is controlled by whichever lever is depressed.

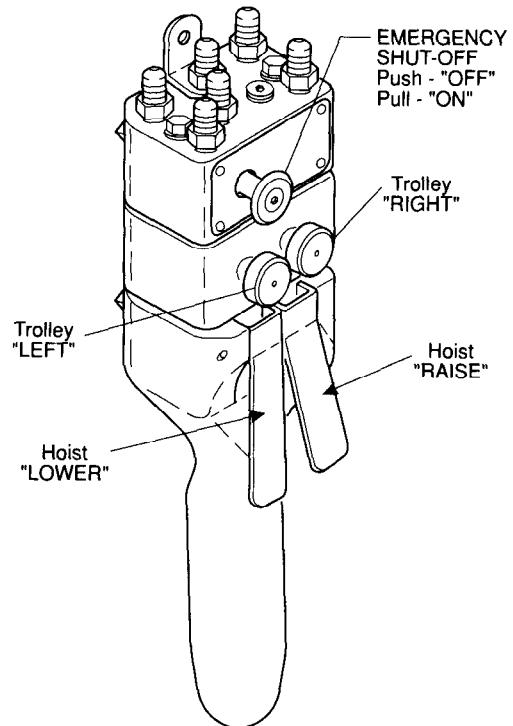

(Dwg. MHTPA0395)

### Pilot Two Lever Pendant

(Ref. Dwg. MHTPA0396)

The pilot two lever pendant is standard on hook mounted hoists without the emergency stop option.

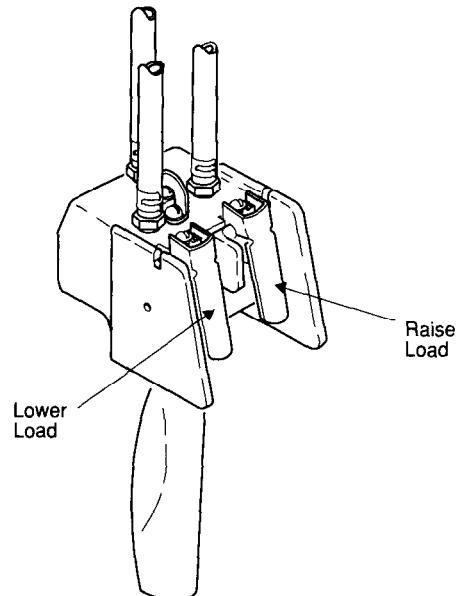

(Dwg. MHTPA0427)

**Accu-Trol® Pendant (Push Button Type) Optional**

The Accu-Trol® pendant is available with 2, 4 or 6 buttons. Refer to Accu-Trol® Pendant manual form number MHD56014 for additional information. (4 button pendant shown).

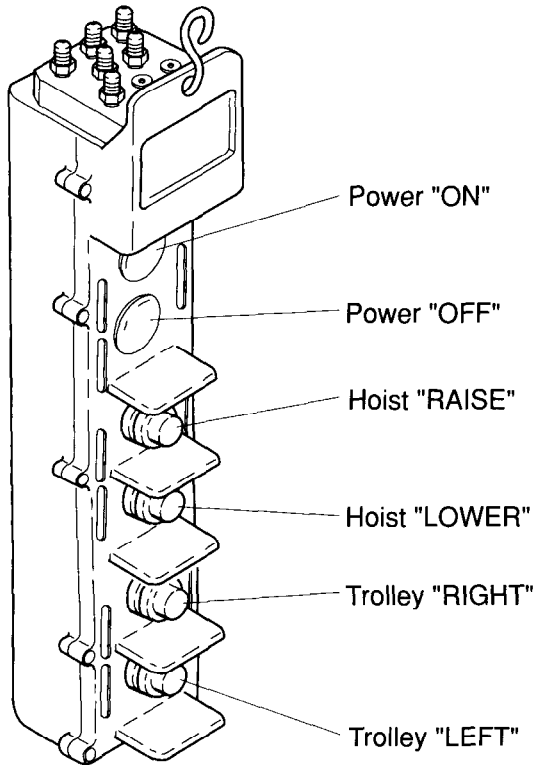

(Dwg. MHTPB0434)

**Attaching the Load**

**⚠ WARNING**

• The hook latch is intended to retain loose slings or devices under slack conditions. Hook latches are not intended to be an anti-fouling device, so caution must be used to prevent the latch from supporting any of the load.

**⚠ WARNING**

• All new, altered or modified equipment should be inspected and tested by personnel trained in safety, operation and maintenance of this equipment to ensure safe operation at rated specifications before placing equipment in service.

Frequent and periodic inspections should be performed on equipment in regular service. Frequent inspections are visual examinations performed by operators or personnel trained in safety and operation of this equipment and include observations made during routine equipment operation. Periodic inspections are thorough inspections conducted by personnel trained in the safety, operation and maintenance of this equipment. ASME B30.16 states inspection intervals depend upon the nature of the critical components of the equipment and the severity of usage. Frequent and periodic inspection intervals for equipment use under various operating conditions are listed below:

1. Frequent Inspection:

<b>NORMAL</b>	<b>HEAVY</b>	<b>SEVERE</b>
monthly	weekly	daily

2. Periodic Inspection:

<b>NORMAL</b>	<b>HEAVY</b>	<b>SEVERE</b>
yearly	semi-annually	quarterly

Careful inspection on a regular basis will reveal potentially dangerous conditions while still in the early stages, allowing corrective action to be taken before the condition becomes dangerous.

Deficiencies revealed through inspection, or noted during operation, must be reported to designated personnel trained in safety, operation and maintenance of this equipment. A determination as to whether a condition constitutes a safety hazard must be decided, and the correction of noted safety hazards accomplished and documented by written report before placing the equipment in service.

**Records and Reports**

Inspection records, listing all points requiring periodic inspection should be maintained for all load bearing equipment. Written reports, based on severity of service, should be made on the condition of critical parts as a method of documenting **periodic** inspections. These reports should be dated, signed by the person who performed the inspection, and kept on file where they are readily available for review.

**NOTICE**

• The external placement of coded marks on equipment identifying completed inspections and operationally certified equipment is an acceptable method of documenting periodic inspections in place of written records.

**Load Chain Reports**

Records should be maintained documenting the condition of load chain removed from service as part of a long-range load chain inspection program. Accurate records will establish a relationship between visual observations noted during frequent inspections and the actual condition of the load chain as determined by periodic inspection methods.

**Frequent Inspection**

On hoists in continuous service, frequent inspection should be made at the beginning of each shift. In addition, visual inspections should be conducted during regular service for any damage or evidence of malfunction.

1. OPERATION. Check for visual signs or abnormal noises (grinding etc.) which could indicate a defect. Make sure all controls function properly and return to neutral when released. Check chain feed through the hoist and bottom block. If chain binds, jumps, is excessively noisy or "clicks", clean and lubricate the chain. If problem persists, replace the chain. Do not operate the hoist until all defects have been corrected.
2. HOOKS. Check for wear or damage, increased throat width, bent shank or twisting of hook. Replace hooks which exceed the throat opening discard width specified in Table 3 (see Dwg. MHTPA0040) or exceed a 10° twist (see Dwg. MHTPA0111). If the hook latch snaps past the tip of the hook, the hook is sprung and must be replaced. Refer to the latest edition of ASME B30.10 "HOOKS" for additional information.

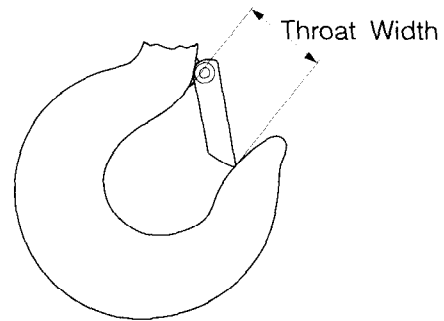

(Dwg. MHTPA0040)



**Table 3**

Hoist Model	Hook Throat Opening			
	New Hook		Discard Hook	
	in.	mm	in.	mm
HA1-005 (Steel)	1.87	47.6	2.15	54.6
HA1-005 (Bronze)	2.25	57.2	2.58	65.5
HA1-010 (Steel)	2.50	63.5	2.87	73.0
HA1-010 (Bronze)	3.37	85.7	3.88	98.5
HA1-015 (Steel)	3.37	85.7	3.88	98.5
HA1-015 (Bronze)	4.15	105.4	4.77	121.1
HA1-020 (Steel)	4.00	101.6	4.60	116.8
HA1-020 (Bronze)	4.50	114.3	5.17	131.3

3. **UPPER AND LOWER LIMIT DEVICE.** Test operation with no load. Upward travel must stop when the bottom block or stop buffer on chain hits hoist limit arm.
4. **AIR SYSTEM.** Visually inspect all connections, fittings, hoses and components for indication of air leaks. Repair any leaks found.
5. **CONTROLS.** During operation of hoist, verify response to pendant is quick and smooth. If hoist responds slowly or movement is unsatisfactory, do not operate hoist until all defects have been corrected.

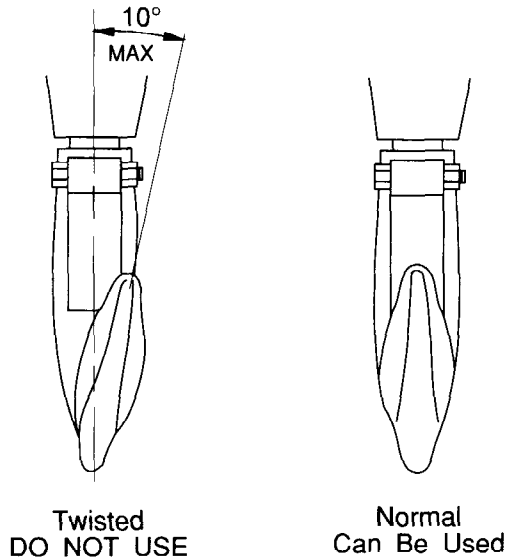

(Dwg. MHTPA0111)

6. **HOOK LATCH.** Make sure the hook latch is present and operating. Replace if necessary.

7. **CHAIN.** Examine each of the links for bending, cracks in weld areas or shoulders, traverse nicks and gouges, weld splatter, corrosion pits, striation (minute parallel lines) and chain wear, including bearing surfaces between chain links (see Dwg. MHTPA0102). Replace a chain that fails any of the inspections. Check chain lubrication and lubricate if necessary. Refer to "Load Chain" in "LUBRICATION" section.

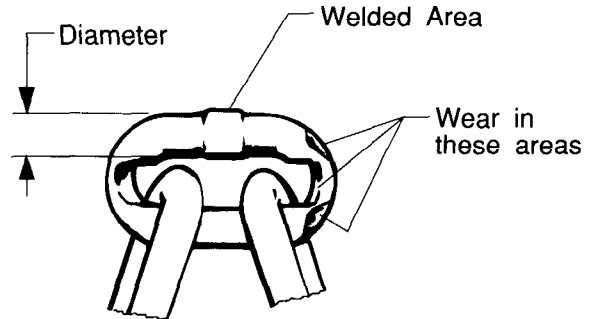

(Dwg. MHTPA0102)

**NOTICE**

• It may not be possible to determine the full extent of chain wear or stretching by visual observation. At any indication of wear or stretching inspect the chain in accordance with instructions in "Periodic Inspection".

8. **CHAIN REEVING.** Ensure welds on standing links are away from load sheave. Reinstall chain if necessary. Make sure chain is not capsized, twisted or kinked. Adjust as required.

**Periodic Inspection**

**NOTICE**

• Refer to "INSPECTION AND MAINTENANCE REPORT" for guidance on documenting periodic inspection items.

Disassembly may be required as a result of initial indications of inspections or in order to properly inspect the individual components. Disassembly steps are described in the "MAINTENANCE" section. Maintain written records of periodic inspections to provide an accumulative basis for continuing evaluation. Inspect all items listed in "Frequent Inspection." Also inspect the following:

1. **FASTENERS.** Check all rivets, split pins, capscrews and nuts. Replace if missing or tighten if loose.
2. **ALL COMPONENTS.** Inspect for wear, damage, distortion, deformation and cleanliness. If external evidence indicates the need, disassemble. Check gears, shafts, bearings, sheaves, chain guides, springs and covers. Replace worn or damaged parts. Clean, lubricate and reassemble.

3. **HOOKS.** Inspect hooks carefully for cracks using magnetic particle or other suitable non-destructive method. Inspect hook retaining parts. Tighten or repair, if necessary.
4. **CHAIN SHEAVES.** Check for damage or excessive wear. Replace if necessary.
5. **MOTOR (Hoist and Trolley).** If performance is poor, disassemble the motor and check for wear or damage to bearings and shafts. The parts should be cleaned, lubricated and reassembled. Replace worn or damaged parts.
6. **BRAKE.** Raise a load equal to the rated capacity of the hoist a few inches off the floor and check ability of hoist to hold the load without drift. If drift occurs, disassemble. Check rotating disc lining thickness as noted in the "MAINTENANCE" section.
7. **SUPPORTING STRUCTURE.** Check for distortion, wear and continued ability to support load.
8. **TROLLEY.** Check that the trolley wheels track the beam properly and clearance between side rollers and beam is correct, 1/16 to 3/16 in. (2 to 5 mm). Check side plates for spreading due to bending.
9. **LABELS AND TAGS.** Check for presence and legibility. Replace if necessary.
10. **LOAD CHAIN END ANCHORS.** Ensure end of load chain is securely attached to the hoist or bottom block. Secure if loose, repair if damaged, replace if missing. Check chain stopper is correctly installed and functional.
11. **LOAD CHAIN.** Measure the chain for stretching and wear by measuring across five link sections all along the chain paying particular attention to the most frequently reeved links. When any five links in the working length reaches or exceeds the discard length, replace the entire chain (see Dwg. MHTPA0041). Always use a genuine **Ingersoll-Rand** Material Handling replacement chain for regular and nickel-diffused load chains.

12. **CHAIN CONTAINER.** Check for damage or excessive wear and that chain container is securely attached to the hoist. Secure or replace if necessary.
13. **LIMIT ASSEMBLY.** Check limit arm moves freely and activates limit switches for maximum upper and lower hook travel.

#### Hoists Not in Regular Use

1. Hoists which have been idle for a period of one month or more, but less than six months shall be given an inspection conforming with the requirements of "Frequent Inspection" before being placed into service.
2. Hoists which have been idle for a period of over six months shall be given a complete inspection conforming with the requirements of "Periodic Inspection" before being placed into service.
3. Standby hoists shall be inspected at least semi-annually in accordance with the requirements of "Frequent Inspection". If abnormal operating conditions apply hoists may require a more frequent inspection.

Size (mm)	Normal Length		Discard Length	
	in.	(mm)	in.	(mm)
16.0	8.86	225	9.02	229

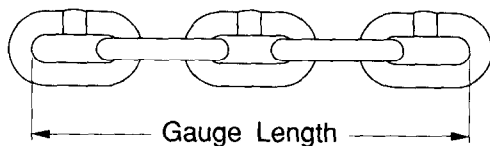

(Dwg. MHTPA0041)

### NOTICE

• A worn load chain may cause the load sheave to wear rapidly. Inspect the load sheave and replace if damaged or worn.

**INSPECTION AND MAINTENANCE REPORT  
MODEL HA1 AIR CHAIN HOIST**

<b>Model Number:</b>	<b>Date:</b>
<b>Serial Number:</b>	<b>Inspected by:</b>

**Reason for Inspection: (Check Applicable Box)**

<input type="checkbox"/>	1. Scheduled Periodic Inspection ( ___ Monthly ___ Quarterly ___ Yearly).
<input type="checkbox"/>	2. Discrepancy(s) noted during Frequent Inspection.
<input type="checkbox"/>	3. Discrepancy(s) noted during maintenance.
<input type="checkbox"/>	4. Other: _____

Refer to the Parts, Operation and Maintenance Manual "INSPECTION" section for general inspection criteria. Also, refer to appropriate National Standards and codes of practice. If in doubt about an existing condition contact the nearest INGERSOLL-RAND Distributor or the factory for technical assistance.

COMPONENT	CONDITION		CORRECTIVE ACTION		NOTES
	Pass	Fail	Repair	Replace	
Fasteners					
Gears					
Shafts					
Bearings			---		
Load Bearing Sheaves			---		
Chain Guides			---		
Springs			---		
Covers					
Hooks:					
Top	Actual Hook Throat Width: _____ inches / _____ mm (reference Table 3 for minimum/maximum acceptable widths).				
	Hook Twist			---	(maximum 10%)
	Hook Crack Test Method Used: ___ Dye Penetrant ___ Magnetic Particle ___ Other: _____				
Bottom	Actual Hook Throat Width: _____ inches / _____ mm (reference Table 3 for minimum/maximum acceptable widths).				
	Hook Twist			---	(maximum 10%)
	Hook Crack Test Method Used: ___ Dye Penetrant ___ Magnetic Particle ___ Other: _____				
Hook Latch			---		
Brake (10% Load Test)					
Brake (Visual Inspection)					
Tail Pin (Chain End Anchor)					
Load Chain			---		
Working length(s) maximum wear/stretch: _____ inches / _____ mm (ref. load chain dimensions for maximum acceptable wear/stretch).					
Supporting Structure					
Labels and Tags			---		
Other Components (list in NOTES section)					

Testing:	Pass	Fail
Operational (No Load)		
Operational (10% Load)		
Operational (Maximum Test Load *)		

\* Refer to the Parts, Operation and Maintenance manual "Testing" in the "MAINTENANCE" section to determine Maximum Test Load.

# LUBRICATION

To ensure continued satisfactory operation of the hoist, all points requiring lubrication must be serviced with the correct lubricant at the proper time interval as indicated for each assembly. Correct lubrication is one of the most important factors in maintaining efficient operation.

The lubrication intervals recommended in this manual are based on intermittent operation of the hoist eight hours each day, five days per week. If the hoist is operated almost continuously or more than the eight hours each day, more frequent lubrication will be required. Also, the lubricant types and change intervals are based on operation in an environment relatively free of dust, moisture, and corrosive fumes. Use only those lubricants recommended. Other lubricants may affect the performance of the hoist. Approval for the use of other lubricants must be obtained from your **Ingersoll-Rand** Technical Support Department or distributor. Failure to observe this precaution may result in damage to the hoist and/or its associated components.

INTERVAL	LUBRICATION CHECKS
Start of each shift	<p>Check flow and level of air line lubricator (approximately 4 to 6 drops per minutes required at maximum motor speed).</p> <p>Check oil levels in the hoist and trolley piston motors.</p>
Monthly	<p>Lubricate all grease fittings.</p> <p>Clean air line filter.</p> <p>Check oil level in the brake and reduction gear assembly.</p>
6 Monthly	<p>Drain and replace oil in trolley and hoist piston drive motors.</p>
Yearly	<p>Drain and refill oil in the hoist brake and reduction gear assembly.</p>

### Pivot Points and Bushings

Lubricate grease fittings monthly with 2 or 3 pumps from a grease gun or more frequently, depending on severity of service. For temperatures -20° to 50° F (-29° to 10° C) use a multipurpose lithium-based EP 1 grease. For temperatures 30° to 120° F (-1° to 49° C) use a multipurpose lithium-based EP 2 grease.

### Hoist Motor

The motor is splash lubricated by the oil in the motor housing and has no other means of lubrication. It is therefore important to use only high quality, non-detergent hydraulic oil to insure maximum performance and minimum down time for repairs. Allow oil to settle prior to topping off. Oil capacity for the HA1 hoist motor is 0.1 gals. (0.38 ltrs.).

Below 32° F (0° C)	SAE 10W Hydraulic Oil
32° to 80° F (0° to 27° C)	SAE 20W Hydraulic Oil*
Above 80° F (27° C)	SAE 30W Hydraulic Oil

\* Hoists are shipped from the factory with this oil

### Trolley Drive Motor (piston)

The motor is splash lubricated by the oil in the motor housing and has no other means of lubrication. It is therefore important to use only high quality, non-detergent hydraulic oil to insure maximum performance and minimum down time for repairs. Allow oil to settle prior to topping off. Oil capacity for the HA1 trolley drive motor is 0.1 pints (65 ml).

Below 32° F (0° C)	SAE 20W Hydraulic Oil
32° to 80° F (0° to 27° C)	SAE 30W Hydraulic Oil*
Above 80° F (27° C)	SAE 40W Hydraulic Oil

\* Hoists are shipped from the factory with this oil

### Bottom Hook Block Assembly

To prevent moisture entering the bottom block assemblies they should periodically be disassembled and repacked with grease. For temperatures -20° to 50° F (-29° to 10° C) use a multipurpose lithium-based EP 1 grease. For temperatures 30° to 120° F (-1° to 49° C) use a multipurpose lithium-based EP 2 grease. Add grease to bottom hook assemblies through grease fittings (39).

Hoist Capacity	Grease Required to Pack Hook Assembly	
	ozs.	grams
HA1-005 (5 ton)	0.33	31
HA1-010 (10 ton)	1.1	204
HA1-015 (15 ton)	1.1	468
HA1-020 (20 ton)	7.2	873

## Hoist Lubrication Points

### Hook Mounted Hoist

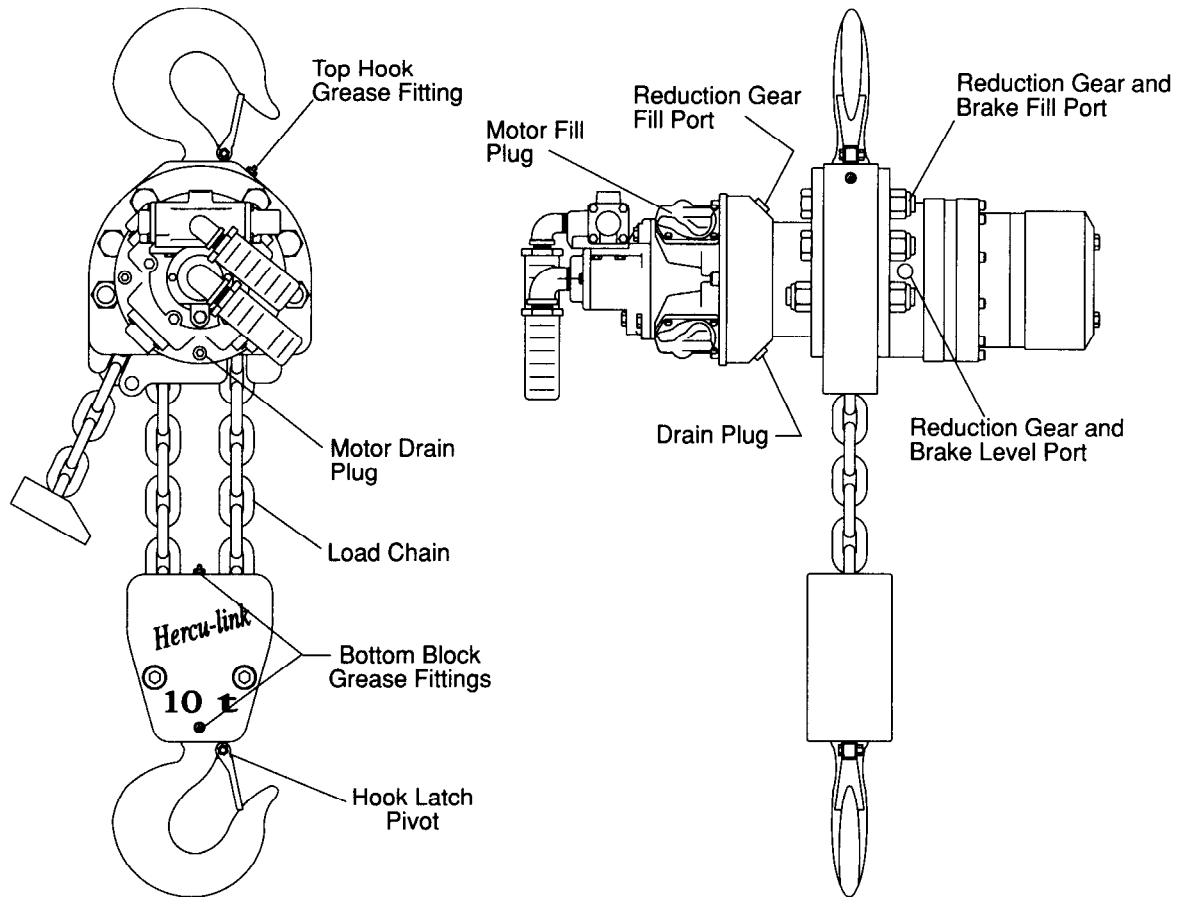

(Dwg. MHTPA0509)

### Load Chain



• Failure to maintain clean and well lubricated load chain will result in rapid load chain wear that can lead to chain failure which can cause severe injury, death or substantial property damage.

1. Lubricate load chain weekly, or more frequently, depending on severity of service.
2. In a corrosive environment, lubricate more frequently than normal.
3. Lubricate each link of the load chain and apply new lubricant over existing layer.
4. Lubricate hook and hook latch pivot points.
5. If required, clean chain with acid free solvent to remove rust or abrasive dust build-up and lubricate the chain.
6. Use **Ingersoll-Rand LUBRI-LINK®** or a SAE 50 to 90 EP oil.

### Trolley Drive Assembly

The gear housing is filled at the factory and shipped with the proper amount of oil, a non-toxic, rust inhibiting worm gear oil AGMA #7 compound that is suitable for an ambient temperature of 50° F to 125° F (10° C to 52° C). Before placing the hoist in operation, make certain that the breather (237) in the gear housing (212) is clean and unrestricted.

### Lubricant Chart

Temperature Range	Recommended Lubricant
50° to 125° F (10° to 52° C)	AGMA #7 (EP 7)
-10° to 50° F (-23° to 10° C)	AGMA #5 (EP 5)

Fill gear housing (212) through port with breather (237) to the height of level plug (201) hole located in the cover (202). The gear housing oil capacity is approximately 0.4 gals. (1.5 lts.)

After the first 10 hours of operation, the oil should be changed. Thereafter it should be changed every 100 hours of service or every 6 months whichever occurs first. The oil is drained by removing pipe plug (213) located underneath the gear housing (212). The oil should be replaced using one of the recommended lubricants or its equivalent.

### Reduction Gear Assemblies

The reduction gear assemblies are filled and shipped with oil from the factory. There are two reduction gear assemblies, check oil level on both sides before initial hoist operation. If the hoist is used at a normal frequency replace the oil in the reduction housing once every year.

To ensure correct performance, highest efficiency and long life, it is essential that the lubricating oil be maintained at the correct level. Brake side oil capacity for the reduction gear assembly is 0.3 gals (1.1 lts). Motor side oil capacity for the reduction gear assembly is 0.3 gals (1.1 lts). Refer to Dwg. MHTPA0509 for fill, level and drain port locations.

### CAUTION

• **Do not over fill. Excess oil will reduce operating efficiency and increase oil temperature.**

Use only high quality lubricants in the reduction gear assembly such as SAE 90 EP motor oil or high grade EP4 gear oil.

The recommended grade of oil must be used at all times since the use of unsuitable oil may result in excessive temperature rise, loss of efficiency and possible damage to the gears. Check breathers (24) are clean and unrestricted.

### Brake Assembly

The brake assembly is lubricated from oil in the reduction gear assembly on the brake side of the hoist. If oil has been drained or hoist has been disassembled check oil level in reduction gear assembly prior to operating hoist.

### CAUTION

• **Do not over fill. Excess oil will reduce operating efficiency and increase oil temperature.**

Use only high quality lubricants in the disc brake housing assembly such as SAE 90 EP motor oil or high grade EP4 type gear oil.

The recommended grade of oil must be used at all times since the use of unsuitable oil may result in excessive temperature rise, loss of efficiency and possible damage to the brake discs.

### Seals and Bearings

If hoist is disassembled, clean all parts thoroughly and coat bearings and seals with clean grease. Use sufficient grease to provide a good protective coat. Lubricate grease fittings monthly with 2 or 3 squirts from a grease gun.

For temperatures -20° to 50° F (-30° to 10° C) use a multipurpose lithium-based EP 1 grease.

For temperatures 30° to 120° F (-1° to 49° C) use a multipurpose lithium-based EP 2 grease.

### Trolley

Lubricate grease fittings monthly with 2 to 3 squirts from a grease gun. Grease fittings are located on trolley side plates at each trolley wheel location. Use grease as recommended for seals and bearings.

## TROUBLESHOOTING

This section provides the information necessary for troubleshooting this hoist. The troubleshooting guide provides a general outline of problems which could be experienced with normal use of this hoist. It lists the symptom, the possible cause, and the possible remedy for the trouble being experienced.

SYMPTOM	CAUSE	REMEDY
Hoist will not operate.	No air supply to hoist, or too little CFM or PSI.	Check PSI (bar) at valve inlet. Refer to "SPECIFICATIONS" section for correct CFM (cu.m/min) and PSI (bar).
	Valve or limit arm sticking.	Check limit arm for free movement.
	Emergency valve "OFF".	Turn air "ON".
	Pendant malfunction.	Check PSI (bar) at pendant. Minimum operating pressure in pendant line is 55 PSI (3.8 bar).
	Hoist is overloaded.	Reduce load to within rated capacity.
	Motor is damaged.	Repair or replace. See "MAINTENANCE" section. Check oil level in motor and gearbox.
	Lubricator is low on oil.	Fill lubricator.
Load continues to move when hoist is stopped. "UP" direction.	Valve sticking.	Check limit arm for free movement.
	Dump valves not releasing.	Check pendant dump valves.
	Pendant lever sticking.	Check lever and restore free movement.
Load continues to move when hoist is stopped. "DOWN" direction.	Valve sticking.	Check limit arm for free movement.
	Dump valves not releasing.	Check pendant dump valves.
	Brake is slipping.	Check brake springs and rotating disc linings. See "MAINTENANCE" section.
	Hoist is overloaded.	Reduce load to within rated capacity.
Hoist will not lift load.	Pendant lever sticking.	Check lever and restore free movement.
	Hoist is overloaded.	Reduce load to within rated capacity.
	No air supply to hoist, or too little CFM or PSI.	Check PSI (bar) at valve inlet. Refer to "SPECIFICATIONS" section for correct CFM (cu.m/min) and PSI (bar).
	Main air valve travel is restricted.	Check limit arm and linkage for free movement.
	Exhaust restricted.	Inspect vents and replace mufflers.
	Motor is damaged.	Check for worn motor bearings.
Motor or gearbox out of oil.	Check oil levels in motor and gearbox and fill to required level. Check oil level in lubricator.	

<b>SYMPTOM</b>	<b>CAUSE</b>	<b>REMEDY</b>
Hook lowers, but will not raise.	No air supply to hoist, or too little CFM (cu.m/min).  Hoist is overloaded.  Pendant malfunction.	Check power supply and connections, in power supply line.  Reduce load to within rated capacity.  Check PSI (bar) at green colored fitting connection on pendant.
Hook can be raised but not lowered.	Pendant malfunction.	Check PSI (bar) at yellow colored fitting connection on pendant.
Load chain jumps on sheave or is making a snapping sound.	No oil on load chain.  Worn or rusted chain.  Worn load sheave.  Hoist not in-line with load.  Incorrectly reeved load chain.	Lubricate load chain. See "LUBRICATION" section.  See "INSPECTION" to determine wear limit. Replace if necessary.  Replace worn parts.  Align hoist with load. Do not "yard" or side pull.  Check load chain is correctly reeved.
<b>Trolley</b> Trolley won't stop or trolley wheels slip.	Damaged beam.  Too much oil, grease or paint on track of beam.  Trolley not spaced for beam clearance.	Repair or replace beam.  Clean off oil, grease or paint.  Check trolley spacing. Refer to "INSTALLATION" section.
Trolley won't run.	Pendant lever sticking.  Emergency valve "OFF".  No air supply to trolley, or too little CFM (cu.m/min) or PSI (bar).  Control valve is sticking.  No oil in trolley motor or gearbox.  Wheels may be obstructed.  Motor is damaged.	Check lever and restore free movement.  Turn air "ON".  Check PSI (bar) at trolley valve.  See "MAINTENANCE" section.  Check oil levels in trolley motor and gearbox and fill to required level.  Remove obstruction.  Repair or replace. See "MAINTENANCE" section.



**⚠ WARNING**

- Never perform maintenance on the hoist while it is supporting a load.
- Before performing maintenance, tag controls:  
**DANGER - DO NOT OPERATE - EQUIPMENT BEING REPAIRED.**
- Only allow personnel trained in service and repair on this hoist to perform maintenance.
- After performing any maintenance on the hoist, dynamically test hoist to 100% of its rated capacity, in accordance with ASME B30.16 standards, before returning hoist to service.
- Turn off air system and depressurize air lines before performing any maintenance.

INTERVAL	MAINTENANCE CHECKS
Start of each shift	Lubricate as recommended in "LUBRICATION" section. Make a thorough visual inspection of the hoist for damage. Do not operate the hoist if damage is found. Check the operation of the pendant control and brake.
See "INSPECTION" section for recommended intervals	Conduct maintenance as needed to correct problems noted during inspection.
Annually	Inspect the gearing, shafts, and bearings for damage or wear. Check all of the supporting members, including the trolley if used.

**Disc Brake Adjustment**

No brake adjustment is required.

**NOTICE**

- When any part of the friction disc thickness measures 0.200 in. (5.08 mm) or less, or if oil groove pattern is not clearly visible, the friction discs must be replaced.

**Load Chain Replacement**

It is suggested that a short length of 16 mm load chain be available when replacing the hoist load chain. Feeding a short length of load chain through the bottom block assembly or power head assembly prior to installing the new load chain may simplify installation.

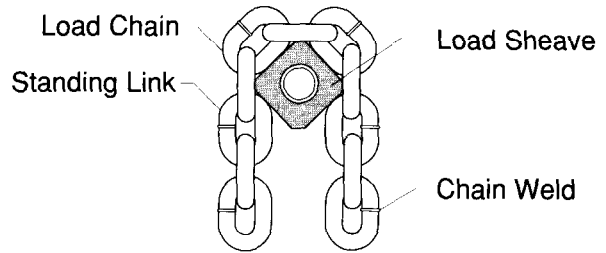

(Dwg. MHTPA0042)

Weld on perpendicular load chain must always face away from sheaves. See Dwg. MHTPA0042.

**HA1-005 Hoist (Ref. Dwg. MHTPA0428)**

1. The hoist should be hung and connected to the air supply. Reduce hoist air pressure to 60 psi (4 bar).
2. Remove chain bucket, if used.
3. Remove capscrew (242) and load chain stopper (241).
4. Remove bottom block assembly (400).
5. Cut new load chain to length. Load chain must have an even number of links (first and last links must be at 90° to each other).
6. Run hoist slowly in the lifting direction until the load chain free end is approximately 2 ft (60 cm) from the hoist.
7. Using a "C" link (Ref. Dwg. MHTPA0016) which is the same size as the load chain join the new load chain to the old taking care that the weld on the perpendicular "standing" links on the new load chain are facing away from the hoist load sheave. Feed new load chain alphabetically as indicated on Dwg. MHTPA0428.



**"C" Link**

(Dwg. MHTPA0016)

8. Run the hoist slowly until the new load chain has passed 2 to 3 feet (60 to 90 cm) through the hoist. Remove the "C" link and old chain.
9. Install chain stopper (241) in last link of the load chain free end and secure with capscrew (242).
10. Install bottom block assembly (400).
  - a. Install washer on load chain for hoists equipped with limit switches.

- Lubricate entire length of load chain before operating hoist. Refer to "LUBRICATION" section.

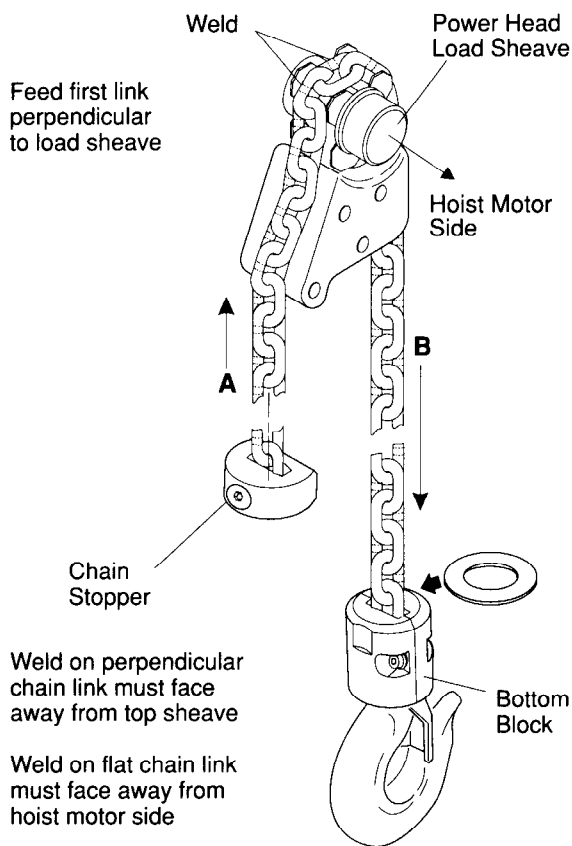

(Dwg. MHTPA0428)

### Chain Replacement

#### HA1-010 Hoist (Ref. Dwg. MHTPA0337)

- The hoist should be hung and connected to the air supply. Reduce hoist air pressure to 60 psi (4 bar).
- Remove chain bucket, if used.
- Remove capscrew (242) and load chain stopper (241).
- Run hoist slowly in the lifting direction until the bottom block assembly (400) is approximately 3 ft (1 m) from the hoist power head. Firmly support and secure the bottom block assembly (400) in this position.



• Do not begin chain replacement until bottom block assembly is fully secured and supported. If the bottom block assembly or chain are dropped, they could cause injury or damage property.

- Cut new load chain to length. Load chain must have an even number of links (first and last links must be at 90° to each other).
- Remove capscrew (48) and nut (46) which anchor the load chain to the chain stripper (45) on the power head assembly.

- Using a "C" link (Ref. Dwg. MHTPA0016) which is the same size as the load chain join the new load chain to the free end on the old chain taking care that the weld on the perpendicular "standing" links on the new chain are facing away from the hoist load sheave.
- Run the hoist slowly until the new load chain has passed through the hoist. Continue running hoist and pull chain by hand through bottom block assembly (400). Begin feeding chain at position 'A' and work alphabetically. Remove the "C" link and old chain.
- Anchor the end of the load chain to the power head assembly with capscrew (48) and nut (46). Install chain stopper (241) in last link of load chain free end and secure with capscrew (242).
- Lubricate entire length of load chain before operating hoist. Refer to "LUBRICATION" section.

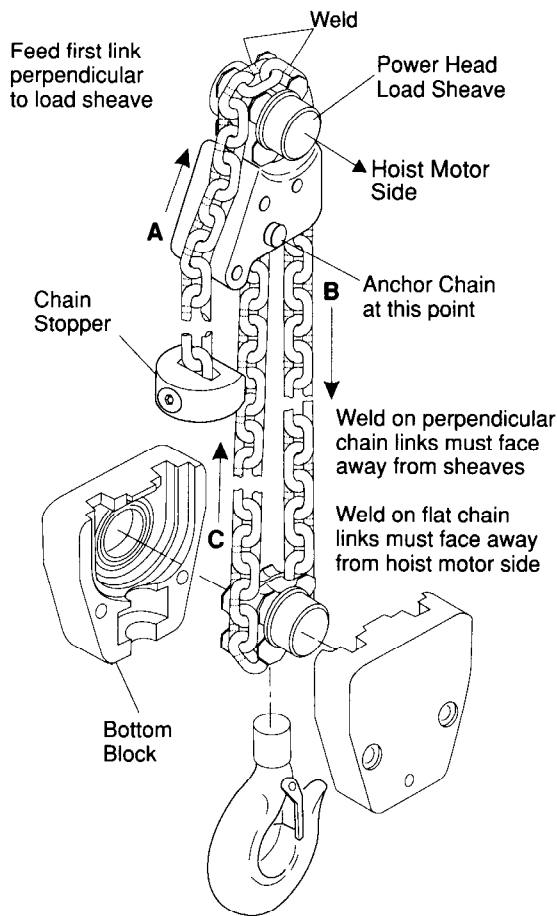

(Dwg. MHTPA0337)

### Chain Replacement

#### HA1-015 Hoist (Ref. Dwg. MHTPA0516)

- The hoist must be hung and connected to the air supply. Reduce hoist air pressure to 60 psi (4 bar).
- Remove chain bucket, if used.
- Remove capscrew (242) and load chain stopper (241).
- Run hoist slowly in the lifting direction until the bottom block assembly (400) is approximately 3 ft (1 m) from the hoist power head. Firmly support and secure the bottom block assembly (400) in this position.

## ⚠ WARNING

• Do not begin chain replacement until bottom block assembly is fully secured and supported. If the bottom block assembly or chain are dropped, they could cause injury or damage property.

5. Cut new load chain to length. Load chain must have an odd number of links (first and last links must be in the same plane/parallel to each other).
6. Remove plug (408) and pin (402) which anchor load chain to bottom block assembly.
7. Using a "C" link (Ref. Dwg. MHTPA0016) which is the same size as the load chain join the new load chain to the free end on the old chain taking care that the weld on the perpendicular "standing" links on the new chain are facing away from the hoist load sheave.

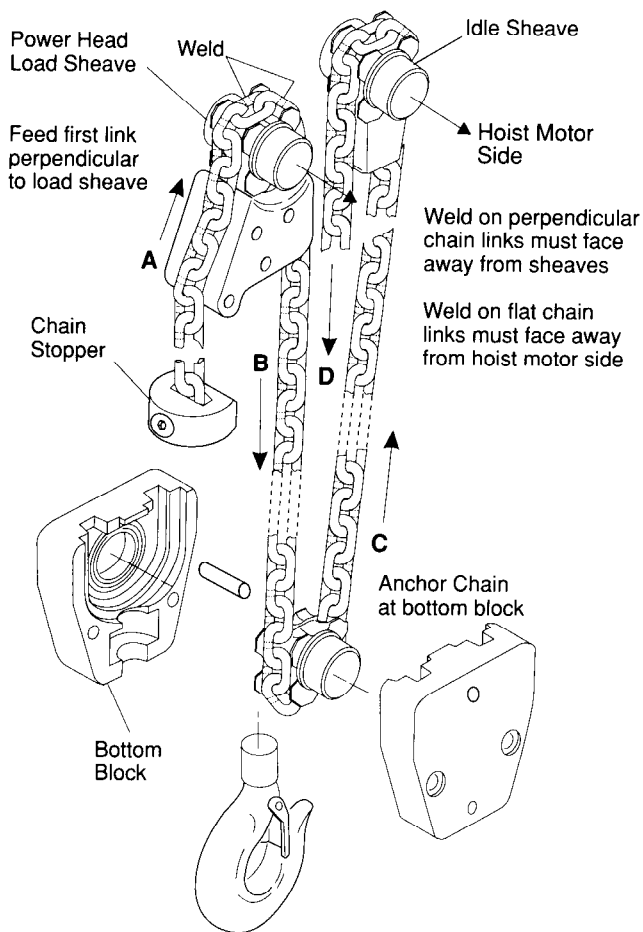

(Dwg. MHTPA0516)

8. Run the hoist slowly until the new load chain has passed through the hoist. Continue running hoist and pull chain by hand through the bottom block assembly (400). Begin feeding chain at position 'A' and work alphabetically. Remove the "C" link and old chain.

9. Attach the end of the load chain to the bottom block assembly with pin (402) and plug (408). Install chain stopper (241) in last link of load chain free end and secure with capscrew (242).
10. Lubricate entire length of load chain before operating hoist. Refer to "LUBRICATION" section.

## Chain Replacement

**HA1-020 Hoist** (Ref. Dwg. MHTPA0331)

1. The hoist must be hung and connected to the air supply. Reduce hoist air pressure to 60 psi (4 bar).
2. Remove chain bucket, if used.
3. Remove capscrew (242) and load chain stopper (241).
4. Run hoist slowly in the lifting direction until the bottom block assembly (400) is approximately 3 ft (1 m) from the hoist power head. Firmly support and secure the bottom block assembly (400) in this position.

## ⚠ WARNING

• Do not begin chain replacement until bottom block assembly is fully secured and supported. If the bottom block assembly or chain are dropped, they could cause injury or damage property.

5. Cut new load chain to length. Load chain must have an even number of links (first and last links must be at 90° to each other).
6. Remove retainer ring (79) and pin (78) which anchor load chain to the chain stripper on the power head assembly.
7. Using a "C" (Ref. Dwg. MHTPA0016) link which is the same size as the load chain join the new load chain to the free end on the old load chain taking care that the weld on the perpendicular "standing" links on the new load chain are facing away from the hoist load sheave.
8. Run the hoist slowly until the new load chain has passed through the hoist. Continue running hoist and pull chain through the bottom block assembly (400). Begin feeding chain at position 'A' and work alphabetically. Remove the "C" link and old chain.
9. Anchor the end of the load chain to the power head assembly with pin (78) and retainer rings (79). Install chain stopper (241) in last link of load chain free end and secure with capscrew (242).
10. Lubricate entire length of load chain before operating hoist. Refer to "LUBRICATION" section.

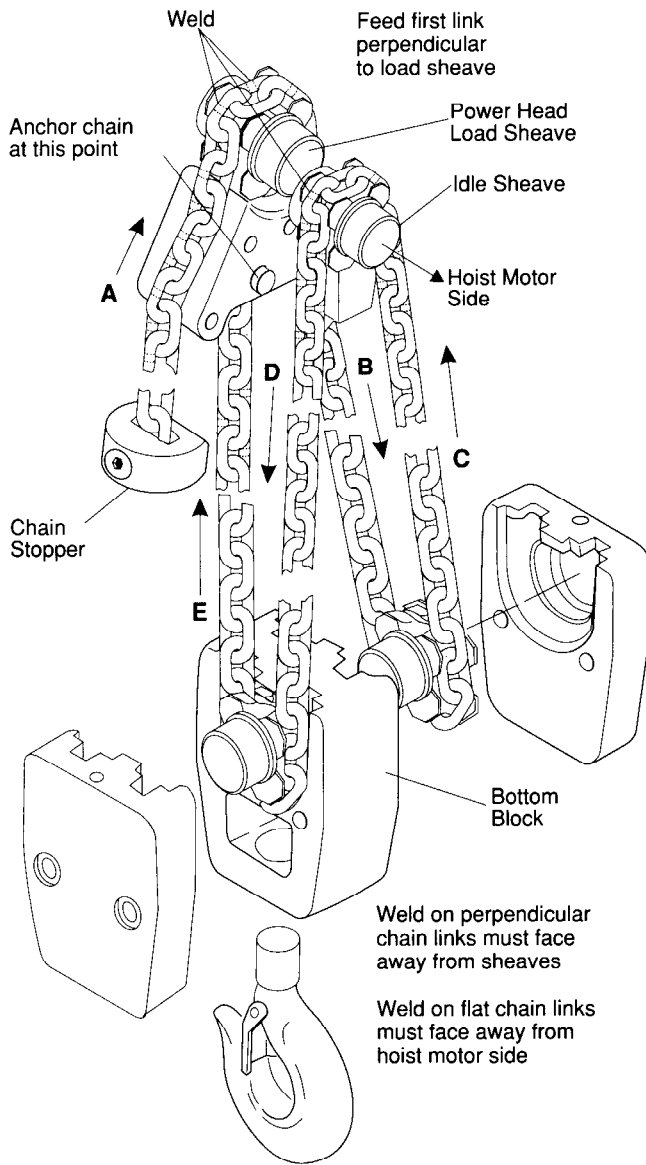

(Dwg. MHTPA0331)

### General Disassembly

The following instructions provide the necessary information to disassemble, inspect, repair, and assemble the hoist. Parts drawings of the hoist assembly are provided in the Parts Section.

If a hoist is being completely disassembled for any reason, follow the order of the topics as they are presented.

It is recommended that all maintenance work on the hoist be performed on a bench in a clean dust free work area.

In the process of disassembling the hoist, observe the following:

1. Turn off air system and depressurize air lines before performing any maintenance. Disconnect hoses from hoist and trolley. Plug or cap openings to keep out dirt and contaminants.

2. Never disassemble the hoist any further than is necessary to accomplish the needed repair. A good part can be damaged during the course of disassembly.
3. Never use excessive force when removing parts. Tapping gently around the perimeter of a cover or housing with a soft hammer, for example, is sufficient to break the seal.
4. Do not heat a part with a flame to free it for removal, unless the part being heated is already worn or damaged beyond repair and no additional damage will occur to other parts.

In general, the hoist is designed to permit easy disassembly and assembly. The use of heat or excessive force should not be required.

5. Keep the work area clean to prevent dirt and other foreign matter from getting into bearings and other moving parts.
6. All seals, 'O' rings and back-up rings should be discarded once they have been removed. New seals, 'O' rings and back-up rings should be used when assembling the hoist.
7. When grasping a part in a vise, always use leather or copper covered vise jaws to protect the surface of the part and help prevent distortion. This is particularly true of threaded members and machined surfaces.
8. Do not remove any part which is press fit in or on a subassembly unless the removal of that part is necessary for repairs or replacement.
9. To avoid damaging bearings during hoist assembly or disassembly always tap or press on the bearing inner race for shaft fit bearings or the outer race for bore fit bearings.

### Trolley Disassembly

(Ref. Dwg. MHTPC0530)

1. On motorized trolley's remove capscrews (236) and lockwashers (235) then separate trolley drive assembly from side plate (173).
2. Remove cotter pin (178) and pin (177) from suspension shaft (174).
3. Remove side plate (150) or (173) and spacers (157) from suspension shafts (174). Record the position of spacers (157) for later reassembly.
4. Remove hoist assembly from suspension shafts (174) with remaining spacers (157), (175) and (176).
5. Remove capscrews (162) and nuts (164) from side plate (150) and pull out suspension shafts (174).
6. Remove retainer ring (156) and spacer (155) and pull wheels (153) or (172) from side plates.

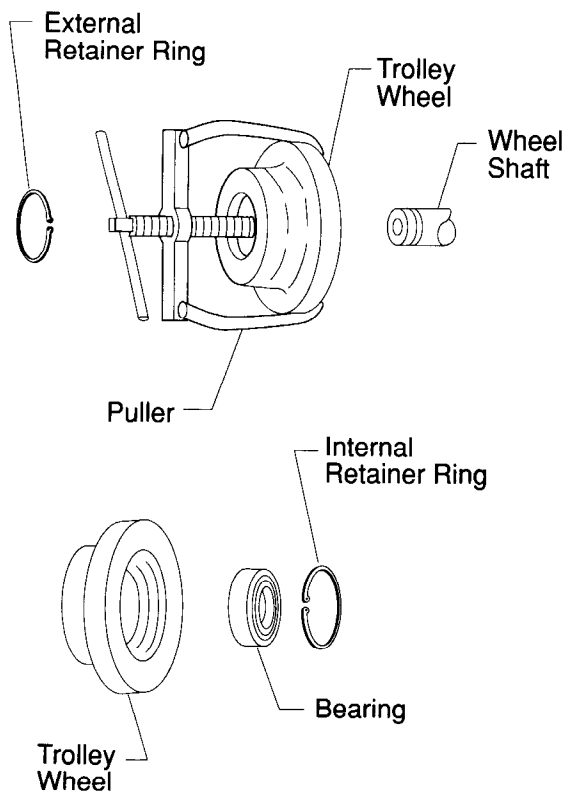

(Dwg. MHTPA0414)

7. Remove oil seal (151) and retainer ring (152) from wheels (153) or (172). Press bearing (154) out of wheels (153) or (172). Refer to Dwg. MHTPA0414.

#### Hand Chain Trolleys

(Ref. Dwg. MHTPA0528)

- a. Remove split pin (294), nut (293) and washer (292) from pinion extension (287).
- b. Remove handwheel (290) and washer (288).
- c. Remove retainer rings (289) and bushings (295).
- d. Pull pinion extension (282) from trolley side plate.

#### Power Head Disassembly

(Ref. Dwg. MHTPD0506, MHTPC0519 and MHTPC0520)

1. Disconnect all hoses from hoist motor. On trolley mounted hoists remove hoist assembly from trolley. Drain oil from reduction gear assemblies, brake and motor assembly. Position power head assembly vertically so brake end is up.
2. Remove four capscrews (86) and lockwashers (235) and pry motor assembly (328) from adapter (67). Check location of pinion (64) it may remain attached to the motor crank shaft assembly. Remove gasket (68). Set motor assembly to one side. Refer to piston motor disassembly if motor repairs are required.
3. Remove capscrews (70) and lockwashers (69). Pry motor adapter (67) from ring gear (56) and reducer adapter (50).
4. Remove planet gear assembly and ring gear (56).

5. Position power head assembly so motor end is down. Remove four capscrews (118) and lockwashers (235) which secure brake assembly (1) to brake adapter (5). Remove brake cover (116) and gasket (115). Pull brake assembly (1) and gasket (115) from brake adapter.
6. Remove capscrews (3) and lockwashers (4). Pry brake adapter (5) from ring gear (7). Carefully pull out input shaft (53).
7. Remove planet gear assembly, ring gear (7) and thrust washers (8) from internal gear (17).
8. Remove capscrews (18), (19) and nuts (22) from large gear housing (26).
9. Pry large gear housing (26) from top frame (38). On 20 ton hoists also remove frame drive side (82).

#### 15 ton Hoist Only

Remove capscrews (76) and retainer plates (75) from large gear housing (26) and reducer adapter (50).

10. Remove stud (33), chain stripper (45) and pins (49). Tap out load sheave (44) with bearings (28).

#### 15 and 20 ton Hoists

Remove idle stripper (73) and idle sheave (74).

11. Pull bearings from load sheave (44) and remove 'O' ring retainers (32), 'O' rings (30) and quad rings (29). On 15 and 20 ton hoists also pull bearings from idle sheave (74).
12. Pry reducer adapter from top frame (38). On 20 ton hoists also remove frame idle side (83).
13. Drive out pin (43) and unscrew nut (42) from threaded hook section. Remove bearing (40).
14. Pull hook (36) from top frame (38).
15. Remove screws (34) and inserts (35).

If planet gear assemblies require disassembly proceed as follows:

16. Using a punch with a diameter slightly smaller than the spring pin hole in the planet carrier tap pins (11) or (60) completely into the center of planet gear pins (14) or (62).
17. Tap planet gear pins (14) or (62) out of planet carrier (9) or (63). Remove planet gears (16) or (59), thrust washers (10) or (52) and needle rollers (12) or (58). Avoid dropping or losing needle rollers as they are removed from planet gears.

#### Brake Disassembly

(Ref. Dwg. MHTPB0527)

1. Position brake assembly with shaft protrusion downward. Capscrews (118), lockwashers (117), brake cover (116) and gasket (115) should have been removed during disassembly of brake from the power head assembly.
2. Alternately and evenly loosen capscrews (114) until brake spring compression is relaxed. Remove capscrews (114), washers (113) and housing (93).

3. The following parts can now be removed, spring retainer (95), primary disc (99), rotating discs (100), springs (96), stationary discs (102) and pins (98).
4. Further disassembly is not recommended and should not be attempted unless necessary for the replacement of specific parts, i.e., seal (90), retainer ring (91), bearing (92), and shaft (97) from housing (93). If necessary proceed as follows:
  - a. Remove seal (90). The seal will be damaged in the process and must be replaced. Be extra careful not to damage the adjacent bearing seal.
  - b. Remove retainer ring (91), then shaft (97) with bearing (92) by lightly tapping the shaft with a plastic mallet.
  - c. Remove shaft from bearing by supporting the inner race of the bearing and applying pressure to the shaft.
5. Remove the piston (103) from the power plate (109) by introducing low pressure air 15 psi (1 bar) into the air inlet port. Make sure piston is directed away from the operator.
6. Remove O-rings (105 and 107) and back-up rings (104 and 106) from the grooves in the piston bore and on the outside diameter. Back-up rings will be damaged and should not be removed if replacement is not planned. Remove retainer ring (91) from power plate (109). Bearing (92) may be removed by tapping it lightly with a plastic mallet.

### **Top Hook Disassembly**

#### **Hook Mount Hoist**

(Ref. Dwg. MHTPD0506)

1. Remove hoist from mounting structure.
2. The top hook can only be removed after partial disassembly of the power head assembly. Refer to power head disassembly for instructions.

### **Bottom Block Disassembly**

#### **HA1-005 Hoist**

(Ref. Dwg. MHTPA0503)

1. Remove capscrews (405), lockwashers (403) and nuts (404) securing side blocks (401). Pry side blocks (401) apart.
2. Remove pin (402).
3. Drive out pin (43) and remove nut (42) on threaded hook section. Remove bearing (40).

#### **HA1-010 Hoist**

(Ref. Dwg. MHTPA0512)

1. Always make sure load chain is removed before disassembly.
2. Remove capscrews (405), lockwashers (403) and nuts (404) securing side blocks (401). Pry side blocks (401) apart.
3. Drive out pin (43) and unscrew nut (42) from threaded hook section. Remove bearing (40).
4. Remove sheave assembly and pull bearings (406) from sheave (407).

#### **HA1-015 Hoist**

(Ref. Dwg. MHTPA0513)

1. Always make sure load chain is removed before disassembly.
2. Remove plug (408) and pin (402) if not already done for load chain removal.
3. Remove capscrews (405), lockwashers (403) and nuts (404) securing side blocks (401). Pry side blocks (401) apart.
4. Drive out pin (43) and unscrew nut (42) from threaded hook section. Remove bearing (40).
5. Remove sheave assembly and pull bearings (406) from sheave (407).

#### **HA1-020 Hoist**

(Ref. Dwg. MHTPB0514)

1. Always make sure load chain is removed before disassembly.
2. Remove capscrews (405), lockwashers (403) and nuts (404) securing side blocks (401) to hook center block (409) and pry side blocks (401) from both sides of hook center block (409).
3. Drive out pin (43) and unscrew nut (42) from threaded hook section. Pull hook (36) from hook center block (409) and remove bearing (40).
4. Remove sheave assemblies and pull bearings (406) from sheaves (407). Remove retainer ring (410) from hook center block (409).

### **Trolley Drive Disassembly**

(Ref. Dwg. MHTPC0306)

1. Remove capscrews (236) and lockwashers (235) then pull trolley drive assembly from trolley side plate (173).
2. Remove retainer ring (180) and drive gear (182) from shaft (208).
3. Remove capscrews (234) and lockwashers (233) from reducer adapter (232). Carefully pry reducer adapter (232) from housing (212).
4. Remove spacer (230) and sleeve (229) from shaft (208). Remove oil seal (228) from reducer adapter (232). Pull shaft (208) with worm gear (226) and bearing (cones) (205) from housing (212).
5. Remove motor adapter (220) from housing (212) with bearing cup (218).
6. Remove four screws (200), cover (225) and cover shims.
7. Pull worm (214) from housing (212).
8. Carefully pull bearing cones (217) from worm (214).
9. Remove oil seal (219) from motor adapter (220).
10. Pull bearing cup (218) out of cover (225).
11. Remove screws (200), cover (202) and gaskets (203) from housing (212).
12. Remove worm gear (226) from shaft (208).
13. Remove bearing cone (205) and spacer (206).

## **Piston Motor Disassembly (Power Head and Trolley Drive)**

(Ref. Dwg. MHTPC0380 and MHTPC0381)

Remove the motor assembly (328 or 329) from the power head or trolley drive assembly and move to a clean work area.

Drain the oil from the motor housing (369) into a suitable container by removing pipe plug (379).

Disassembly and re-assembly will be simplified if the crankshaft (354) is held vertically in a soft-jawed vice or supported vertically on suitable packing, to raise the shaft clear of the work surface.

1. Remove capscrews (334) and valve assembly (625).
2. Remove capscrews (340) and cover (339).
3. Remove capscrews (334) and rotary valve housing (332).
4. Support the rotary valve housing evenly on the flange face. Tap rotary valve (337) out of rotary valve housing (332) from inside outwards. The normal clearance between the rotary valve (337) and rotary valve housing (332) is 0.002 - 0.003 in. (0.05 - 0.075 mm). Replace parts if wear is excessive.
5. Remove the retaining ring (335) and bearing (336) from rotary valve housing (332).
6. Remove setscrew (346) and balance weight (345). Remove spacer washers (347) and note the thickness for subsequent re-assembly.

Instructions 7 through 9 apply to the Trolley Motor Only.

7. Remove the ring (351) now exposed.
8. Remove capscrews (334) and cylinders (375) from motor housing (369). Slide connecting rod (349) along the bearing (352) towards the open end of the motor housing (369), until the connecting rod slipper end is clear of the ring (351). Push out the complete piston assembly, from inside the motor housing (369).
9. When all four piston assemblies (373) have been removed, remove the bearing (352), ring (351) and spacer (353).

Instructions 7A through 9A apply to the Power Head Motor Only.

- 7A. Remove pins (348). This procedure can be accomplished with a bent rod to apply pressure from inside outwards.
- 8A. Remove capscrews (334) and cylinders (375) from motor housing (369). Push out the complete piston assembly, from inside the motor housing (369).
- 9A. When all four piston assemblies (373) have been removed, remove the bearings (352), crank (350) and spacer (353).

Instructions 10 through 12 apply to both the Power Head and Trolley Motors.

10. Remove the retainer ring (366) and spacer (367) and shims (365).

11. Press out crankshaft (354), aligning oil thrower with opening in motor housing (369).
12. Clean off jointing compound from rotary valve housing bore (332) and the outside of the valve bush (136) with "Hermetite" 1325B solvent or similar.

## **Vane Motor Disassembly (Trolley Drive)**

### **Optional Feature**

(Ref. Dwg. MHTPB0379)

1. Remove capscrews (262) from cover (260) and pull vane motor assembly from trolley drive assembly.
2. Remove capscrews (273) and (274). Pull pilot control valve (270) from valve manifold (267).

Pilot control valve (270) repair should be limited to the removal of the end caps, bushings and plunger to replace the 'O' rings. See Dwg. MHTPB0407.

3. Remove capscrews (268) and valve manifold (267) from cylinder (256).
4. Remove capscrews (265) and pry cover (260) from cylinder (256).
5. Remove cover (253) from cylinder (256).
6. Slide shaft and rotor (259) from cylinder (256). Be careful not to drop or damage vanes (258) during removal.
7. Remove capscrews (264) and cap (263) from cover (260).
8. Tap bearings (251) from motor adapter (220) and cover (260).

## **Cleaning, Inspection and Repair**

Use the following procedures to clean, inspect, and repair the components of the hoist.

### **Cleaning**



- **Bearings that are loose, worn or rotate in the housing must be replaced. Failure to observe this precaution will result in additional component damage.**
- **Do not use trichloroethylene to clean parts.**

Clean all hoist component parts in solvent (except for the friction discs). The use of a stiff bristle brush will facilitate the removal of accumulated dirt and sediments on the gears and frames. If bushings have been removed it may be necessary to carefully scrape old Loctite® or gasket material from the bearing bores and gasket surfaces. Dry each part using low pressure, filtered compressed air.

### **Inspection**

All disassembled parts should be inspected to determine their fitness for continued use. Pay particular attention to the following:

1. Inspect all gears for worn, cracked, or broken teeth.
2. Inspect all bushings for wear, scoring, or galling.

3. Inspect shafts for ridges caused by wear. If ridges caused by wear are apparent on shafts, replace the shaft.
4. Inspect all threaded items and replace those having damaged threads.
5. Measure the thickness of the friction rotating discs (100). If the friction rotating discs are less than 0.200 in. (5.08 mm), if oil groove pattern is not clearly visible or surfaces are heavily scored replace the friction rotating discs (100). Thickness of a new friction rotating disc is 0.226 in. (5.74 mm).
6. Check mufflers (266), (144) and (145) for damage or excessive dirt.
8. Check bearings for freeness of rotation and wear. Replace bearings if rotation is rough or bearings are excessively worn.

### Repair

Actual repairs are limited to the removal of small burrs and other minor surface imperfections from gears and shafts.

Use a fine stone or emery cloth for this work.

1. Worn or damaged parts must be replaced. Refer to the applicable parts listing for specific replacement parts information.
2. Inspect all remaining parts for evidence of damage. Replace or repair any part which is in questionable condition. The cost of the part is often minor in comparison with the cost of redoing the job.
3. Smooth out all nicks, burrs, or galled spots on shafts, bores, pins, or bushings.
4. Examine all gear teeth carefully, and remove nicks or burrs.
5. Polish the edges of all shaft shoulders to remove small nicks which may have been caused during handling.
6. Remove all nicks and burrs caused by lockwashers.
7. Replace all seals, 'O' rings and gaskets.

### Assembly Instructions

#### Trolley Assembly

(Ref. Dwg. MHTPC0530)

Preassemble side plate on Hand Chain Trolleys. Skip to instruction 1 for Plain and Motorized Trolleys.

- a. Lubricate and install bushings (286) and pinion extension (287) in side plate (173). Install spacer (285) and retainer ring (179).
- b. Install washer (288) and handwheel (290) on pinion extension. Ensure splines in handwheel align with splines on pinion extension.
- c. Install bushings (295) in side frame (173) and secure with retainer rings (289).
- d. Install washer (292) and nut (293). Tighten nut until snug and back off approximately one quarter turn until cotter pin hole is aligned. Install cotter pin (294) and bend ends apart.
1. Press bearings (154) into wheels (153) or (172). Install retainer rings (152) and oil seals (151) in wheels (153) or (172).

2. Lubricate oil seal lips with grease then install wheels (153) or (172) on side plates. Install spacers (155) and retainer rings (156).
3. Coat suspension shaft (174) ends with grease then install in side plate (150). Install capscrews (162) and nuts (164).
4. Install spacers (157), (175) and (176) in same location as noted during disassembly. Slide assembled side plate and suspension shafts through holes in hoist frame. Install remaining spacers.
5. Install side plate (173). Install pins (177). Secure pins (177) with cotter pins (178) and bend ends apart.
6. Install beam roller guides and bumpers if used.
7. Install trolley drive assembly on side plate (184). Refer to "INSTALLATION" section for trolley adjustment procedure.

### Power Head Assembly

(Ref. Dwg. MHTPD0506, MHTPC0519 and MHTPC0520)

Preassemble planet gear assemblies:

- a. Use a liberal amount of grease on each needle roller (12) or (58). Position needle rollers in bore of planet gears (16) or (59). Use sufficient grease to hold needle rollers in position.
- b. Install planet gear in planet carrier and carefully slide or tap planet shaft (14) through planet carrier and gear. Align pin holes.
- c. Install pins (11) or (60).

### NOTICE

- **Never use pins that are longer than the diameter of planet shaft or later removal will not be possible.**

Assemble brake and planet gear assemblies prior to beginning assembly of power head.

1. Ensure flanged sleeve is tight in reducer adapter (50) and that flange side of sleeve is toward chain sheave.
2. Lubricate and install 'O' rings (30) and quad rings (29) in grooves provided in 'O' ring retainers (32). Install assembled 'O' ring retainers on sheave(s) with seal side facing away from the sheave. Use a small amount of Loctite® 609 on bearing bores and press a bearing (28) onto each side of the sheave(s). Press needle bearing (54) into bore of sheave (44).
3. Install chain stripper (45) on reducer adapter (50) and locate with two pins (49) or one pin (49) and one pin (77) on 20 ton hoists. Install a short length of 16 mm starter chain around sheave(s).

On 15 ton hoists install retainer plate (75) on reducer adapter (50) with four capscrews (76).

On 15 and 20 ton hoists install idle sheave (74) and idle stripper (73). Position idle stripper with pins (49) and (77) on 15 ton hoists and pins (77) and (85) on 20 ton hoists.



4. Install inserts (35) in top frame (38). On 20 ton hoists install one insert on frame drive side (82). Apply Loctite® 242 to flat head screws (34) and secure inserts on each side.
5. Install top frame (38) so it fits over 16 mm starter chain(s). Install capscrews (18) and (19). On 20 ton hoists also install frame idle side (83).
6. Position bearing (40) and nut (42) in top frame (38) and install hook (36) through top frame and bearing. Tighten nut until parts clamp top frame. Back nut off until first dowel pin hole is lined up. Install pin (43). Do not attempt to drive dowel pin (43) into nut until holes are aligned or threads on hook (36) will be damaged. Pack cavity with grease.
7. Ensure flanged sleeve is tight in large gear housing (26) and that flange side of sleeve is toward chain sheave.
8. Apply Loctite® 609 to the bearing outside diameter and sleeve inside diameter in large gear housing (26). Install large gear housing on top frame (38) install studs (33) with nuts (22). On 20 ton hoists also install frame drive side (82). Install remaining nuts (22) and (52). Torque capscrews or nuts to 500-550 lbs. ft. (675-745 N.m). On 15 ton hoists install retainer plate (75) on large gear housing (26) with capscrews (76).

Position Power Head assembly on bench with splined end of load sheave up.

9. Install thrust washer (27) on load sheave (44) spline. Install internal gear (17) on spline of load sheave. Install thrust washer (8).
10. Set timing marks on planet gears and install planet gear assembly in internal gear. (Ref. Dwg. MHTPA0508).

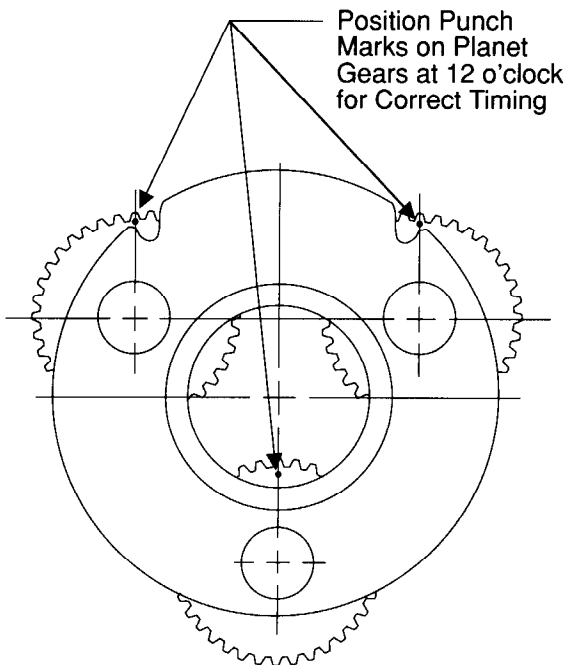

(Dwg. MHTPA0508)

11. Lubricate and install 'O' ring (6) in bore of large gear housing (26). Install ring gear (7). Ring gear may be installed either way. Align capscrew holes.
12. Lube and install 'O' ring (6) in bore of brake adapter (5).
13. Grease thrust washer (8) and place on boss in brake adapter (5) to keep in place as it is assembled.
14. Install brake adapter (5). Position brake adapter so capscrew holes for brake assembly match drawing MHTPA0543.

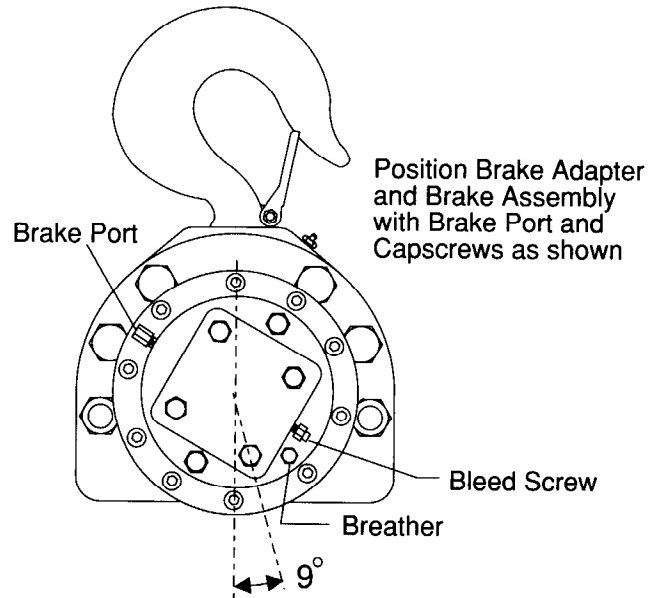

Viewed from Brake Side

(Dwg. MHTPA0543)

15. Install ten capscrews (3) and lockwashers (4) to secure brake adapter (5) to ring gear (7) and large gear housing (26). Torque to 45 lbs. ft dry or 36 lbs. ft. lubricated (61 N.m dry or 50 N.m lubricated).
16. Install drain plugs (23) in large gear housing (26).
17. Install input shaft (53) so gear meshes with planet gears (16). On 20 ton hoists install spacers (78) in the end of input shaft (53) to establish 0.12 in. (3 mm) end play.
18. Install gasket (115) on brake assembly and install brake assembly on brake adapter (5) so brake release port is in line with brake tube hole through top frame (38). When viewed from brake end, it must be located in the 10 o'clock position. Ref. Dwg. MHTPA0543.
19. Position gasket (115) and brake cover (116) on brake assembly. Secure brake assembly in position with capscrews (118) and lockwashers (235). Torque to 63 lb.ft. (85 N.m).

20. Turn power head over so motor end is up. Install spacer (55) on input shaft (53). Install planet gear assembly so spline fits over input shaft. Install plug (66) in motor adapter (67). Apply Loctite® 515 sealant to ring gear (56) face and install ring gear on reducer adapter (50) so it fits over planet gear assembly. Planet gears do not require to be timed. Align capscrew holes.
21. Apply Loctite® 515 to outer face of ring gear (56) and install motor adapter (67) on ring gear. Position motor adapter so plug is located at the bottom (6 o'clock position). Install capscrews (70) and lockwashers (69) to secure motor adapter and torque to 65 to 70 lb. ft. (88 to 95 N.m).
22. Install key (355) and pinion gear (64) on motor crank shaft assembly (354). (refer to instructions for motor assembly.) Install gasket (68) on motor mounting face.
23. Install motor assembly (328) on motor adapter so motor oil filler and valve are to the top. Apply a small amount of Loctite® 242 on capscrew (86) threads and install with lockwashers (235). Torque to 110 lb.ft. (150 N.m).
24. Install valve assembly (625) on motor assembly (238). Ensure gasket (330) is in place. Secure with four capscrews (334). Install piping fittings in valve assembly. Ref. Piping Dwg. MHTPB0552.
25. Install elbow fittings (142) and (143) and mufflers (144) and (145) in valve and motor assembly exhaust ports. Ref. Muffler Dwg. MHTPA0540.
26. Install dump valve (676), brake tube (674) and fittings between valve and brake release port. To prevent brake tube rubbing in the bore of the top frame, install a 5 in. (130 mm) length of 1/4 in. hose material on the outside diameter of brake tube (674). Position brake tube and hose so that it passes through the hole provided in the top frame.
27. Connect pendant hoses. If hoist is equipped with limit switches, pendant hoses connect to the limit switches. If hoist does not have limit switches, pendant hoses connect to the fittings on the valve assembly.

### Brake Assembly

(Ref. Dwg. MHTPB0527)

## NOTICE

• All parts must be thoroughly clean prior to reassembly.

1. Install retainer ring (91) and bearing (92) in power plate if previously removed.
2. Lubricate and install 'O' Rings (105 and 107) and back-up rings (104 and 106) on piston (103).
3. Assemble piston (103) into power plate (109) using a shop press, being careful not to damage the 'O' rings or the Teflon back-up rings. Visually align the center of the cutouts in the piston (103) with the torque pin (98) holes in the power plate (109).

If the shaft and housing were disassembled follow instructions 4 through 6 otherwise skip to instruction 7.

4. Install bearing on shaft (97) by supporting the inner race of the bearing (92) and applying pressure to the shaft.
5. Insert the shaft and bearing in housing (93) and push into position. Secure with retainer ring (91).
6. Install new seal (90).
7. Install spring retainer (95) and springs (96). Position springs as shown in Dwg. MHTPA0525.

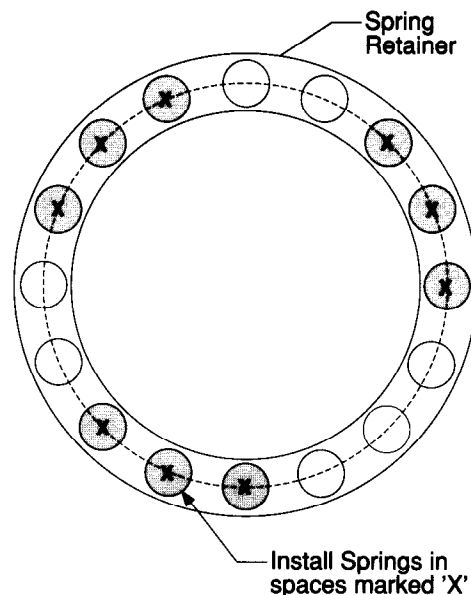

(Dwg. MHTPA0525)

8. Install pins (98) in housing (93). Install primary disc (99) so that the outside slots locate with the pins.
9. Alternately install the rotating discs (100) and stationary discs (102) in housing (93).
10. Alternately tighten capscrews (119) to prevent binding, until snug. Then torque the capscrew to 75 to 85 lb. ft. (100 to 115 N.m) Note: Both shafts must slide together freely. **DO NOT** use capscrews to force the brake assembly together.
11. Install gasket (115) and brake cover (116). Secure in position with capscrews (118) and lockwashers (117).
12. Install gasket (115) on the mounting face of the brake.
13. Place the brake shaft into the gear reducer with the brake fitting (108) in the vertical position.
14. Re-connect air line to the brake port fitting (108).

### Trolley Drive Assembly

(Ref. Dwg. MHTPC0306)

1. Press or tap bearing cup (218) into housing (212) on cover (225) side.
2. Place shims (222, 223 and 224) on shoulder of cover (225).
3. Install cover (225) and gaskets on housing (212). Secure with four screws (200).
4. Press bearing cones (217) onto worm (214). Ensure bearings are fully seated against worm shoulder. Install worm and bearings in housing (212). Tap or press second bearing cup (218) into housing bore.

5. Tap or press bearing cup (204) into cover (202). Place gaskets (203) on shoulder of cover (202).
6. Install cover (202) and gaskets on housing (212). Secure with six screws (200).

### NOTICE

• **Rotate cover (202) so oil level hole is in the 3 o'clock position.**

7. Install keys (207) in shaft (208) and press worm gear (226) onto shaft making sure it aligns with and fits over the keys (207).
8. Install spacers (206) and (227) on shaft. Press bearing cones (205) on shaft (208) until they contact the spacers.
9. Install shaft and worm gear assembly in gear housing (212) so worm gear teeth mesh with worm.
10. Tap or press bearing cup (204) into reducer adapter (232).
11. Install reducer adapter (232) and gaskets (203) on housing (212). Secure with capscrews (234) and lockwashers (233). Check to see if shaft (208) turns freely without binding or moving from side to side.

### NOTICE

• **Adjust gasket (203) quantity to provide zero side to side motion of the worm gear assembly.**

12. Install oil seal (219) in motor adapter (220) so oil seal lip faces into the housing.
13. Install oil seal (228) in reducer adapter (232) so lip faces into the housing.
14. Install motor adapter (220) on housing (212) and secure with screws (200) (piston motor) or screws (234) (vane motor).
15. Install spacer (230) on shaft (208). Take care not to damage the lip of oil seal (228).
16. Install key (183) in shaft (208). Slide drive gear (182) onto shaft (208) so it aligns with and fits over key (183). Install retainer ring (180). Ensure drive gear (182) is installed with recessed side correctly positioned. Ref. Dwg. MHTPA0504.

### NOTICE

• **The first bearing cup (218) must be flush against cover (225) for accurate backlash reading.**

17. Rotate worm to check for tight spots and to see if backlash is between 0.004 - 0.008 in. (0.10 - 0.20 mm). Adjust shims (222, 223 or 224) until correct backlash is achieved.

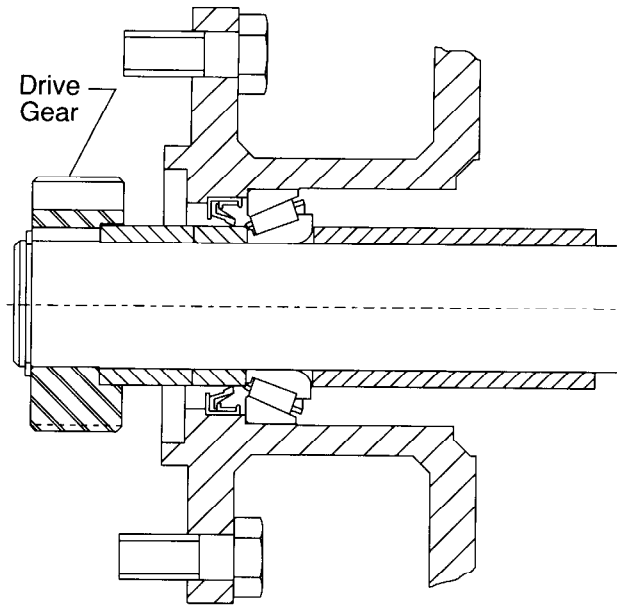

HA1-005, HA1-010 and HA1-015 Hoists  
Install Drive Gear with recess on Retainer Ring side

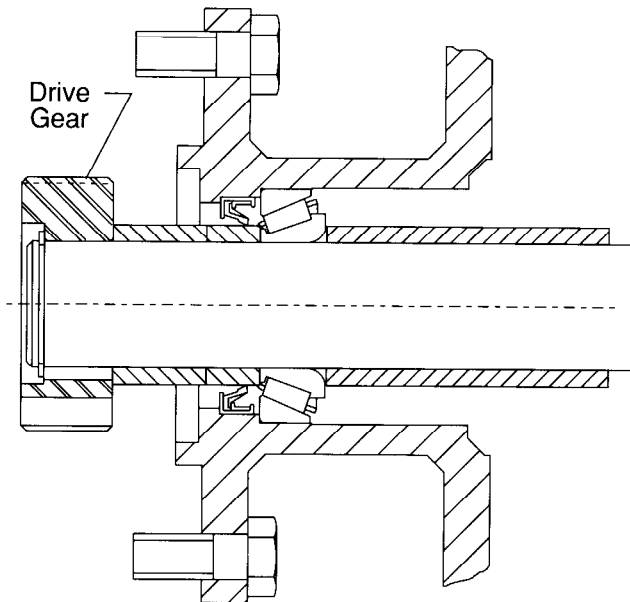

HA1-020 Hoist  
Install Drive Gear with recess on Bushing side

(Dwg. MHTPA0504)

### Piston Motor Assembly (Power Head and Trolley Drive)

(Ref. Dwg. MHTPC0381)

1. Install oil seal (358) and bearings (356) on crankshaft (354). Lip of oil seal (358) must face into motor housing (369). Tap assembled parts into position in flange plate (363).
2. Install shims (365), spacer (367) and retainer ring (366) on the end of crankshaft (354).

3. Lubricate and install 'O' ring (368) on flange plate (363). Align oil-thrower on crankshaft (354) with opening in motor housing (369) and assemble flange plate to motor housing (369) with screws (364).
4. Clamp the crankshaft vertically in a soft-jawed vice. (shaft down)
5. Install spacer (353) so radius on inside bore of spacer is toward the crank pin shoulder.
6. Install ring (351) and bearing (352). Radius on inside bore of ring (351) must face outward.
7. Assemble the connecting rods (349) to the pistons (373). Ensure retainer rings (378) are fully seated in the grooves on wrist pins (377). Install the oil rings (370) and compression rings (372) on the pistons (373). Check gap on rings is 0.003 to 0.004 ins. (0.076 to 0.1 mm). **Note:** The upper compression ring (372) is plain and the lower oil ring (370) acts as an oil control.
8. Carefully install the cylinders (375) on pistons. Do not use force during this procedure and avoid damaging oil rings (370) and compression rings (372).
9. Install a gaskets (374) on each cylinder. Insert the piston assemblies into the motor housing (369) bores, with the connecting rod (349) positioned correctly to seat on the needle bearing (352). When the slipper end is seated on the bearing (352), slide the connecting rod (349) inward to enter the ring (351). Install capscrews (334) so they are finger tight. When all cylinders have been installed tighten capscrews (334) evenly.
10. Install second ring (351) with the radius of the bore innermost. Install spacer (347). Rotate crankshaft 360° to ensure parts are correctly fitted.
11. Install rotary valve (337) in rotary valve housing (332). Press bearings (336) and (338) into rotary valve housing (332). Install retainer ring (335).
12. Install balance weight (345). Secure balance weight with setscrew (346).
13. Rotate the crankshaft (354) until the balance weight is at the bottom dead center position, rotate the rotary valve (337) until the balance weight is at the bottom position.
14. Install gasket (331) on rotary valve housing then assembly to motor housing and secure with capscrews (334). Rotate the output shaft in both directions and viewing the rotary valve (337) through the exhaust cover (339) opening ensure that the valve is correctly following the output shaft direction. This checks that both crank and valve slot are correctly engaged.
15. Install cover (339) and secure with capscrews (340).
4. Install cap (263) on cover (260) with capscrews (264).
5. Apply gasket sealant to the motor cylinder (256) surface for cover (253). Use a minimal amount but enough to create a total seal. Install cover (253) to motor cylinder (256).
6. Install dowels (255) to align cover (253) with motor cylinder (256).

## NOTICE

• **Replacement rotors and cylinders must be supplied as matched sets in order to maintain the proper end running clearance of 0.002 to 0.004 in. (0.05 to 0.1 mm).**

7. Apply a film of 10W oil to the cylinder wall. Install shaft and rotor (259) in cylinder (256). Place one vane (258) in each rotor slot so that the long straight vane edge is towards the cylinder wall.
8. Apply gasket sealant to the motor cylinder (256) surface for cover (260). Use a minimal amount but enough to create a total seal. Install motor cover (260) to motor cylinder (256). Align cover with dowel pin (255) holes and carefully tap cover (260) into position until flush with the cylinder (256).
9. Install dowel pins (255) in cover (260) and cylinder (256). The relationship of the motor end covers (253) and (260) with motor cylinder (256) is very critical. In order to provide proper running clearance for the rotor, the rotor has to run exactly parallel with the cylinder (256) and perpendicular to the covers. Dowel pins (255) are used to locate these parts within 0.007 in. (0.18 mm) of correct alignment.
10. Install capscrews (256). The correct alignment is established by snugging down the capscrews (265) which retain the covers to the cylinder and checking the motor for free turning. If any drag is noted, tap around the edges of the motor covers until the shaft turns freely. Tighten capscrews to 30 in. lbs. (3.3 N.m).
11. Tap shaft key (257) into the keyway on shaft and motor (259).
12. Install valve manifold (267) on cylinder (256) with capscrews (268).
13. Lubricate and install 'O' rings (269) in recesses in pilot control valve (270). Install pilot control valve (270) on valve manifold (267) secure with capscrews (273) and (274).

### Vane Motor Assembly (Trolley)

(Ref. Dwg. MHTPB0379)

1. Install seal (252) in cover (253) so seal (252) is flush with cover face. Seal lip must face towards motor.
2. Install seal (254) in cover (253) so seal lip faces towards the motor.
3. Install bearings (251) in covers (253) and (260) using a small amount of Loctite® 609 on the outside bearing diameter. Pack grease between seal (252) and bearing (251) in cover (253) filling the cavity.

## **Top Hook Assembly Hook Mounted Hoists**

(Ref. Dwg. MHTPD0506)

1. The top hook assembly can only be assembled after partial disassembly of the power head assembly. Refer to the assembly instructions for the power head assembly.

## **Bottom Block Assembly**

### **HA1-005 Hoist**

(Ref. Dwg. MHTPA0503)

1. Pack bearing (40) with grease and install bearing (40) on hook (36) swivel face of bearing (40) should be located nearest the nut (42). Screw nut (42) onto threaded shank of hook (36).
2. Place hook with bearing and nut in one half of side block (401) and tighten nut until parts clamp side block. Back nut off until first dowel pin hole is lined up. Install pin (43). Do not attempt to drive dowel pin (43) into nut until holes are aligned or threads on hook (36) will be damaged.
3. Install pin (402).
4. Pack cavities in side blocks (401) with grease and place side blocks (401) together. Apply a small amount of Loctite® 242 to capscrews threads and install capscrews (405), lockwashers (403) and nuts (404) to clamp parts. Torque capscrews to 85 lb. ft (115 N.m). Check that hook swivels freely.
5. Install grease fitting (39) and fill block with grease. Refer to "LUBRICATION" section.
6. Check latch is installed and functional.

On 10, 15 and 20 ton hoists it is suggested that a short length of 16 mm chain be available when assembling the bottom block assembly. The chain should be installed around the sheave prior to final assembly of the block sections. If this procedure is followed it will simplify the installation of the load chain later.

### **HA1-010 Hoist**

(Ref. Dwg. MHTPA0512)

1. Pack bearing (40) with grease and install bearing (40) on hook (36) swivel face of bearing (40) should be located nearest the nut (42). Screw nut (42) onto threaded shank of hook (36).
2. Place hook with bearing and nut in one half of side block (401) and tighten nut until parts clamp side block. Back nut off until first dowel pin hole is lined up. Install pin (43). Do not attempt to drive dowel pin (43) into nut until holes are aligned or threads on hook (36) will be damaged.
3. Using a press against the inner race of bearing (406) press the bearing (406) onto the sheave (407). Install bearing so shielded side is toward sheave. Repeat the process for the opposite side.
4. Install the assembled sheave in the bottom block. Pack cavities in side blocks (401) with grease and place side blocks (401) together.

5. Secure side blocks (401) with capscrews (405), lockwashers (403) and nuts (404). Use Loctite® 242 on capscrew threads and torque to 360 lb. ft. (488 N.m).
6. Install grease fitting (39) and fill block with grease. Refer to "LUBRICATION" section.
7. Check latch is installed and functional.

### **HA1-015 Hoist**

(Ref. Dwg. MHTPA0513)

1. Pack bearing (40) with grease and install bearing (40) on hook (36) swivel face of bearing (40) should be located nearest the nut (42). Screw nut (42) onto threaded shank of hook (36).
2. Place hook with bearing and nut in one half of side block (401) and tighten nut until parts clamp side block. Back nut off until first dowel pin hole is lined up. Install pin (43). Do not attempt to drive dowel pin (43) into nut until holes are aligned or threads on hook (36) will be damaged.
3. Using a press against the inner race of bearing (406) press the bearing (406) onto the sheave (407). Install bearing so shielded side is toward sheave. Repeat the process for the opposite side.
4. Install the assembled sheave in the bottom block. Pack cavities in side blocks (401) with grease and place side blocks (401) together.
5. Secure side blocks (401) with capscrews (405), lockwashers (403) and nuts (404). Use Loctite® 242 on capscrew threads and torque to 360 lb. ft. (488 N.m).
6. Install grease fitting (39) and fill block with grease. Refer to "LUBRICATION" section.
7. Install pin (402) and plug (408) when anchoring load chain to bottom block assembly.
8. Check latch is installed and functional.

### **HA1-020 Hoist**

(Ref. Dwg. MHTPB0514)

1. Pack bearing (40) with grease and position bearing (40) in hook center block (409) cavity. Swivel face of bearing (40) should be located nearest the nut (42).
2. Install threaded hook end into hook center block (409) and through bearing (40).
3. Install nut (42) being careful that threads are not crossed. Tighten nut (42) until snug then back nut (42) off until first dowel pin hole is lined up. Install dowel pin (43) until flush with nut (42) diameter. Do not attempt to drive dowel pin (43) into nut until holes are aligned or threads on hook (36) will be damaged.
4. Using a press against the inner race of bearing (406) press the bearings (406) onto both sides of sheaves (407). Install bearings so shielded sides are toward sheaves.
5. Install retainer ring (410) in bore of center block (409).
6. Install the assembled sheaves in the hook center block (409). Pack cavities in hook center block (409) and side blocks (401) with grease.

7. Install side plates (401) over bearings (406) and sheaves (407). Secure side plates (401) with capscrews (405), lockwashers (403) and nuts (404). Use Loctite® 242 on capscrew threads and torque to 525 lb. ft. (712 N.m).
8. Install grease fitting (39) and fill block with grease. Refer to "LUBRICATION" section.
9. Check latch is installed and functional.

**Limit Switch (optional feature)**

1. Mount limit switches (454) to spacers (450) with capscrews (458), nuts (453) and lockwashers (451). Do not use the slotted holes in spacers for attaching limit switches.
2. Install spacers with limit switches on reducer adapter (50) with capscrews (452) and lockwashers (451).
3. Adjust the position of the limit switch plunger to ensure a maximum of 1/16 in. (1.6 mm) clearance between limit switch plunger and spring (460). Ref. Dwg. MHTPA0544.

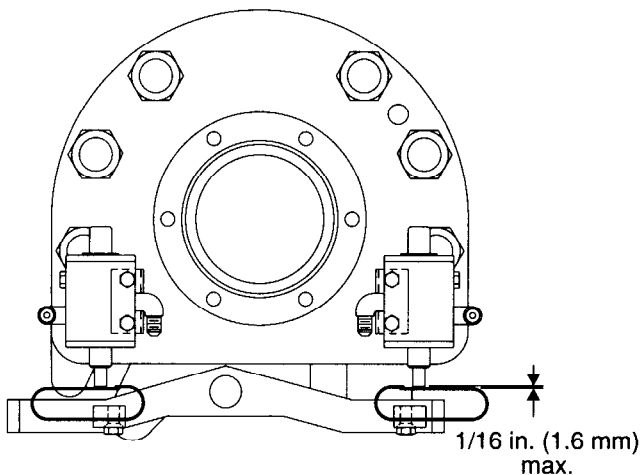

(Dwg. MHTPA0544)

**Load Test**

Prior to initial use, all new, extensively repaired, or altered hoists shall be load tested by or under the direction of a qualified person, and a written report furnished confirming the rating of the hoist. Dynamically load test hoist to 100% of its rated capacity in accordance with ASME B30.16 standards. Testing to more than 100% may be necessary to comply with standards and regulations set forth in areas outside of the USA.

**SERVICE NOTES**

# HOIST DRAWINGS AND PARTS LISTS TABLE OF CONTENTS

Description	Page No.
<b>Hoist</b>	
Power Head Assembly Drawing (MHTPD0506) .....	40
Power Head Assembly Parts List .....	41
Power Head Assembly Drawings for 15 and 20 ton hoists (MHTPC0519 and MHTPC0520) .....	42
Power Head Assembly Parts List (continued) .....	43
Power Head Brake Assembly Drawing (MHTPB0527) .....	44
Power Head Brake Assembly Parts List .....	45
Power Head Piston Motor Assembly Drawing (MHTPC0380) .....	46
Power Head Piston Motor Assembly Parts List .....	47
Bottom Block Assembly Drawings for 15 and 20 ton hoists (MHTPA0513 and MHTPB0514) .....	48
Bottom Block Assembly Drawings 5 and 10 ton hoists (MHTPA0513 and MHTPB0514) .....	49
Load Chain and Chain Stopper Assembly Drawing (MHTPA0507) and Parts List .....	69
<b>Trolley</b>	
Trolley Assembly Drawings (MHTPA0528, MHTPA0529 and MHTPC0530) .....	50
Trolley Assembly Parts List .....	51
Trolley Drive Assembly Drawing (MHTPC0551) .....	52
Trolley Drive Assembly Parts List .....	53
Trolley Drive Piston Motor Assembly Drawing (MHTPC0381) .....	54
Trolley Drive Piston Motor Assembly Parts List .....	55
Trolley Drive Vane Motor Assembly Drawing (MHTPB0379) .....	56
Trolley Drive Vane Motor Assembly Parts List .....	57
Trolley Drive Vane Motor Valve Assembly Drawing (MHTPB0407) and Parts List .....	58
<b>Accessories</b>	
Chain Bucket Assembly Drawings (MHTPA0517 and MHTPA0518) and Parts List .....	59
Limit Switch Assembly Drawing (MHTPA0526) .....	60
Limit Switch Assembly Parts List .....	61
<b>Piping and Controls</b>	
Piping Assembly Drawing (MHTPB0552) .....	62
Piping Assembly Parts List .....	63
Pendant Assembly Drawing (MHTPA0396) .....	64
Pendant Assembly Parts List .....	65
Piston Motor Valve Assembly Drawing (MHTPA0415) and Parts List .....	66
Hose Assembly Drawing (MHTPA0425) and Parts List .....	67
Pendant Assembly Drawing (MHTPA0416) and Parts List .....	68
Rope Control Assembly Drawing (MHTPA0505) .....	70
Rope Control Assembly Parts List .....	71
<b>Miscellaneous</b>	
Trailing Trolley Assembly Drawings (MHTPA0524 and MHTPC0531) .....	72
Trailing Trolley Assembly Parts List .....	73
Hull Bumper Assembly Drawings (MHTPA0521 and MHTPA0522) and Parts List .....	74
Muffler Assembly Drawing (MHTPA0540) and Parts List .....	75
Accessories and Repair Kits .....	75
60 psi Power Head Reducer Assembly Drawing and Parts List (MHTPB0553) .....	76
Label and Tag Parts List (MHTPA0545) .....	77



# HOIST POWER HEAD ASSEMBLY PARTS DRAWING

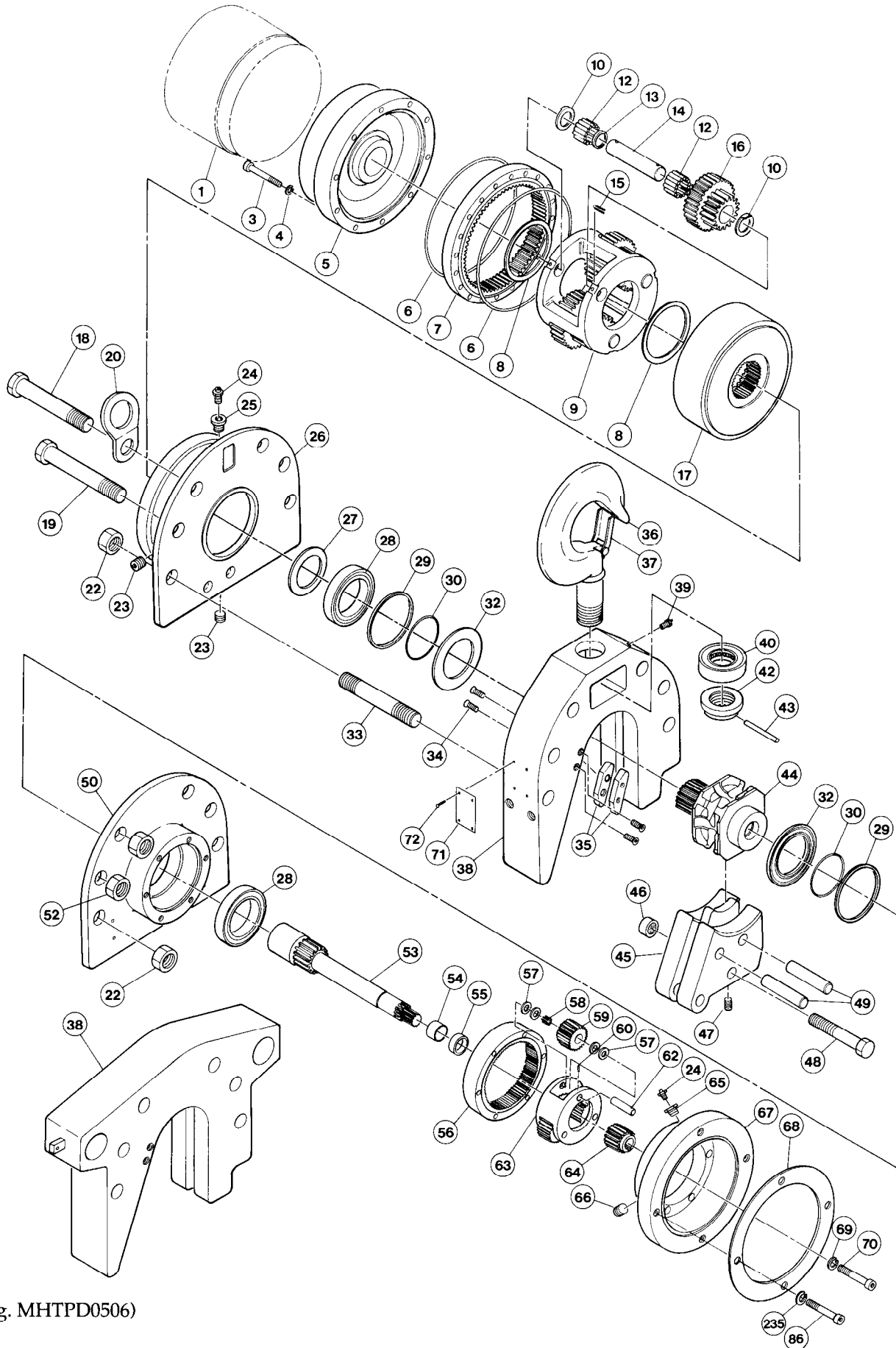

(Dwg. MHTPD0506)

## HOIST POWER HEAD ASSEMBLY PARTS LIST

ITEM NO.	DESCRIPTION OF PART	QTY TOTAL	PART NO.
1	Brake Assembly	1	11864
3	Capscrew	10	54184
4	Lockwasher	10	50200
5	Brake Adapter	1	B-10067
• 6	'O' Ring	2	52553
7	Ring Gear	1	52740
8	Thrust Washer	2	52554
9	Planet Carrier	1	52545
10	Thrust Washer	6	52546
12	Needle Roller	114	52547
13	Spacer	3	52548
14	Planet Shaft	3	52549
15	Pin	3	51124
16	Planet Gear	3	52739
17	Internal Gear	1	12239
20	Lifting Eye	2	9575-1F
22	Nut	4	55037
23	Pipe Plug	4	54912
24	Breather	2	52024
25	Fitting	2	54012
27	Thrust Washer	1	8646-9
28	Bearing (5 and 10 ton hoists)	2	50140
	Bearing (15 and 20 ton hoists)	4	
• 29	Quad Ring	2	71033872
• 30	'O' Ring	2	52025
32	'O' Ring Retainer	2	9454

ITEM NO.	DESCRIPTION OF PART	QTY TOTAL	PART NO.
34	Screw	4	50870
35	Insert	2	9458-1
39	Grease Fitting	1	53095
44	Load Sheave	1	B-10066
47	Setscrew	1	50975
52	Nut	4	51774
54	Bearing	1	50141
55	Spacer	1	11048
56	Ring Gear	1	52738
57	Thrust Washer	12	52733
58	Needle Roller	57	52734
59	Planet Gear	3	52736
60	Pin	3	52737
62	Planet Shaft	3	52735
63	Planet Carrier	1	71008700
64	Pinion	1	10998
65	Reducer Fitting	1	71056824
66	Pipe Plug	1	50801
67	Motor Adapter	1	10999
• 68	Gasket	1	19689
69	Lockwasher	6	50893
70	Capscrew	6	53127
71	Nameplate	1	71070098-R
72	Drive Screw	4	50915
86	Capscrew	4	52317
235	Lockwasher	4	50181

• Recommended Spare

\* Not shown on parts drawing

If replacing complete Reducer Assembly (Brake Side) order part number 12238.  
 If replacing complete Reducer Assembly (Motor Side) order part number 9456.

### Hoists with 60 psi Operation Package (optional Feature)

Refer to page 76 for Reducer Assembly drawing and parts list used in optional 60 psi (4 bar) application.

# POWER HEAD ASSEMBLY PARTS DRAWING (cont'd)

15 ton Hoist

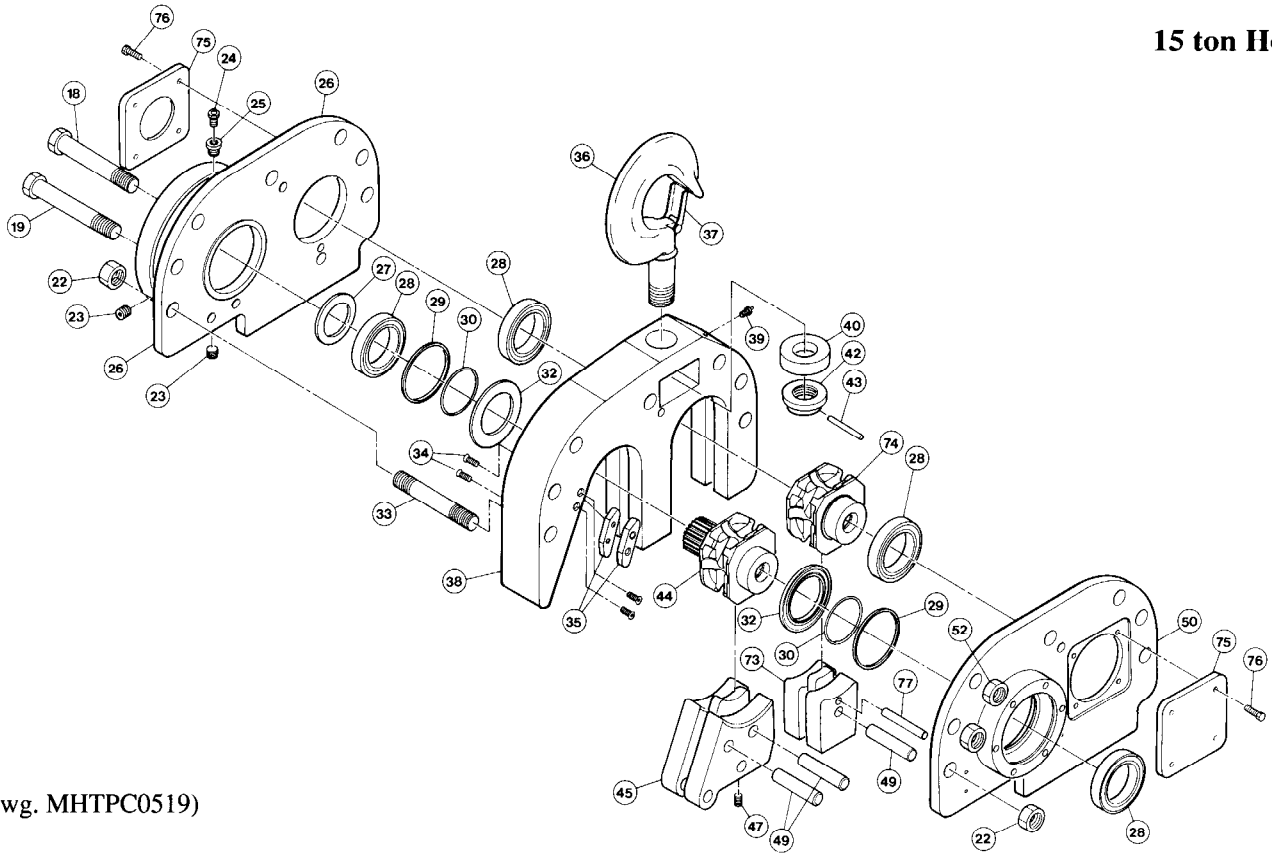

(Dwg. MHTPC0519)

20 ton Hoist

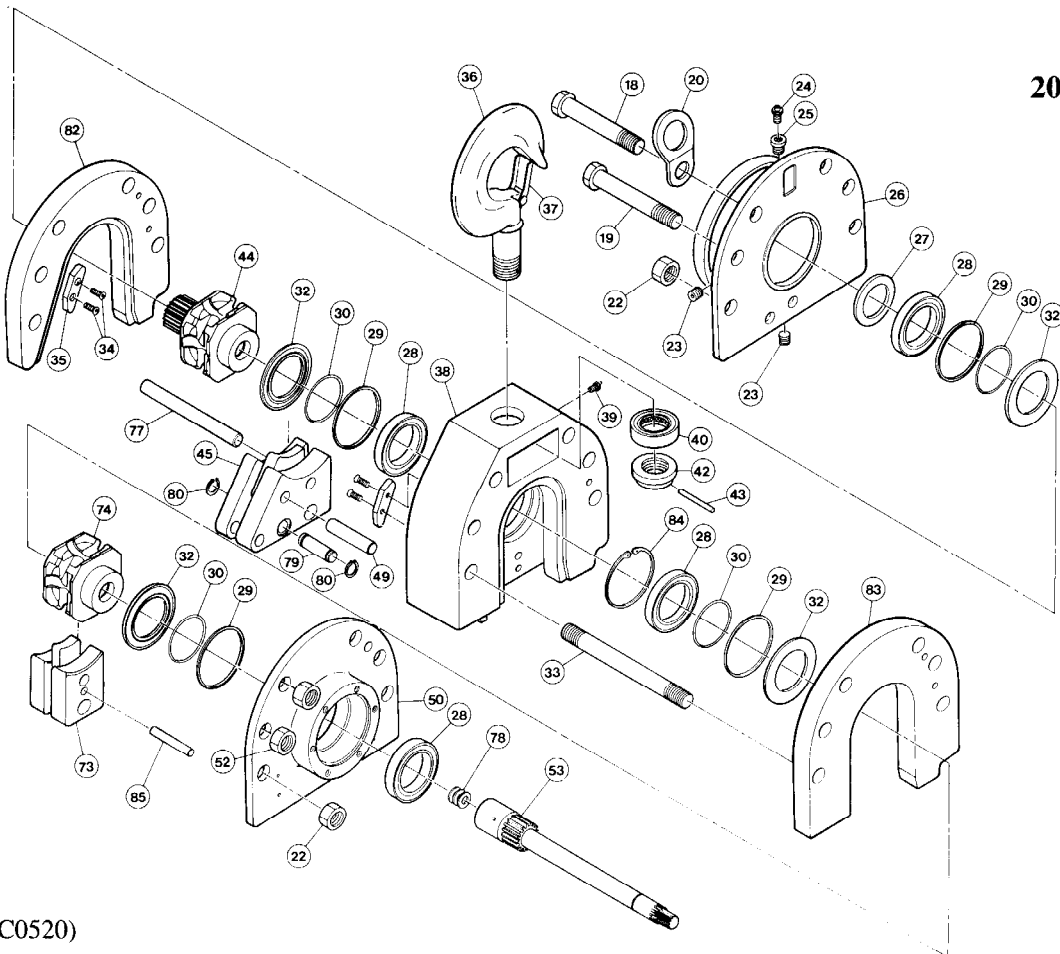

(Dwg. MHTPC0520)

**POWER HEAD ASSEMBLY PARTS LIST (cont'd)**

ITEM NO.	DESCRIPTION OF PART	QTY TOTAL	PART NO.			
			5 ton	10 ton	15 ton	20 ton
18	Capscrew	See ( )	53438 (4)	71068233 (2)		71068241 (4)
19	Capscrew	See ( )		53438 (2)	53438 (3)	
26	Large Gear Housing (Hook Mount)	1	10070-1		10110	10070-1
	Large Gear Housing (Trolley Mount)		10070			10070
33	Stud	2	9457-2			9457-1
36	Top Hook Assembly Steel (incl's Hook Latch Kit item 36)	1	9569	8474-3	9079-1	13702
	Top Hook Assembly Copper Plated (incl's Hook Latch Kit item 36)		18838	18839	18840	18841
	Top Hook Assembly Bronze (incl's Hook Latch Kit item 36)		18036	8937-1	16072	19431
37	Hook Latch Kit	1	51202	50597	50779	52173
	Hook Latch Kit (Bronze)		50597		52894	71054803
38	Top Frame (Hook Mount)	1	9574	9506	11266	10100-2
	Top Frame (Trolley Mount)		10189		10190	10441-2
40	Bearing	1	52291	50144	---	50394
	Washer		---	---	8519-5	---
42	Nut	1	9571	8476	9081	8827
43	Pin	1	52311	50958	50917	50958
45	Chain Stripper	1	9509			9446
46	Nut	1	---	51011		---
48	Capscrew	1	---	53356		---
49	Pin	See ( )	9453-1 (2)	9453-4 (2)	9453-4 (3)	9453-2 (2)
50	Reducer Adapter (Hook Mount)	1	10072-1			10072-1
	Reducer Adapter (Trolley Mount)		B-10072		10111	B-10072
53	Input Shaft	1	12237			13831
73	Idle Stripper	1	---		9550	9447
74	Idle Sheave	1	---		B-10068	B-10069
75	Retainer Plate	2	---		19357	---
76	Capscrew	8	---		51780	---
77	Pin	1	---		9453-7	9453-1
78	Spacer	3	---			71084289
79	Pin	1	---			9449
80	Retainer Ring	2	---			51478
82	Frame Drive Side	1	---			B-10075-1
83	Frame Idle Side	1	---			B-10075-2
84	Retainer Ring	1	---			51069
85	Pin	1	---			9453-3

# POWER HEAD BRAKE ASSEMBLY PARTS DRAWING

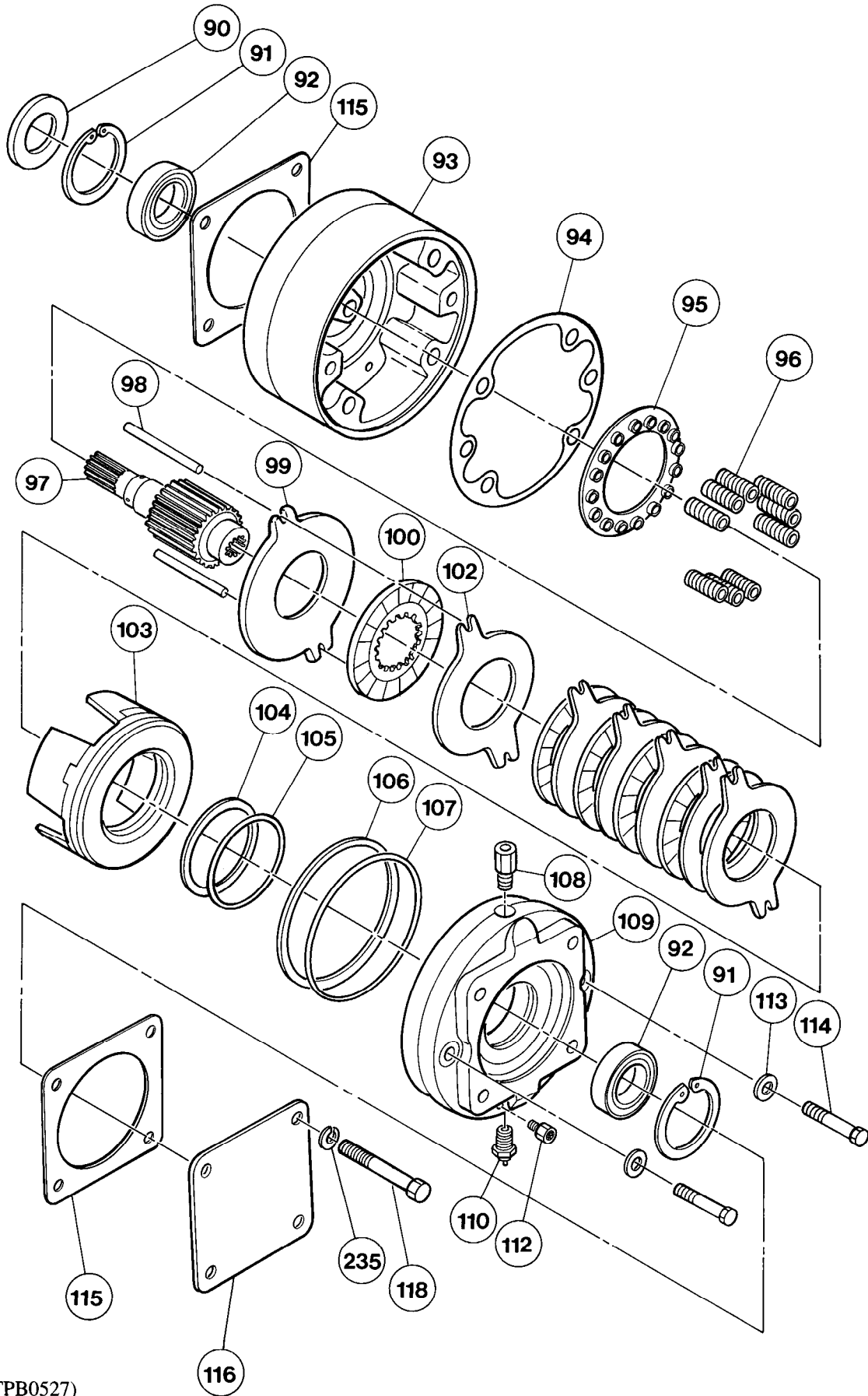

(Dwg. MHTPB0527)

## POWER HEAD BRAKE ASSEMBLY PARTS LIST

ITEM NO.	DESCRIPTION OF PART	QTY TOTAL	PART NO.
1	Brake Assembly (incl's items 90 thru 118 and 235)	1	11864
• 90	Oil Seal	1	52455
91	Retainer Ring	2	55048-21
92	Bearing	2	55048-22
93	Housing	1	52602*
• 94	Gasket	1	52603
95	Spring Retainer	1	71086771
96	Spring	9	71086789
97	Shaft	1	52605
98	Pin	2	52604
99	Primary Disc	1	52606
• 100	Rotating Disc	5	52607
102	Stationary Disc	6	52608
103	Piston	1	52609
• 104	Backup Ring (packing)	1	52203
• 105	'O' Ring	1	50228-13
• 106	Backup Ring (packing)	1	52610
• 107	'O' Ring	1	52611
108	Fitting	1	52184
109	Power Plate	1	52613
110	Bleeder Screw	1	52612
112	Breather	1	71086797
113	Washer	2	50181
114	Capscrew	2	52614
• 115	Gasket	2	52615
116	Brake Cover	1	71086805
118	Capscrew	4	51036
235	Lockwasher	4	50181
• ---	Brake Rebuild Kit (incl's items 90, 94, 96, 100, 105, 106 and 112)	As Req'd	HA1-BRK

\* Part not sold separately. Order complete brake assembly item 1.

•  Recommended Spare

# POWER HEAD PISTON MOTOR ASSEMBLY PARTS DRAWING

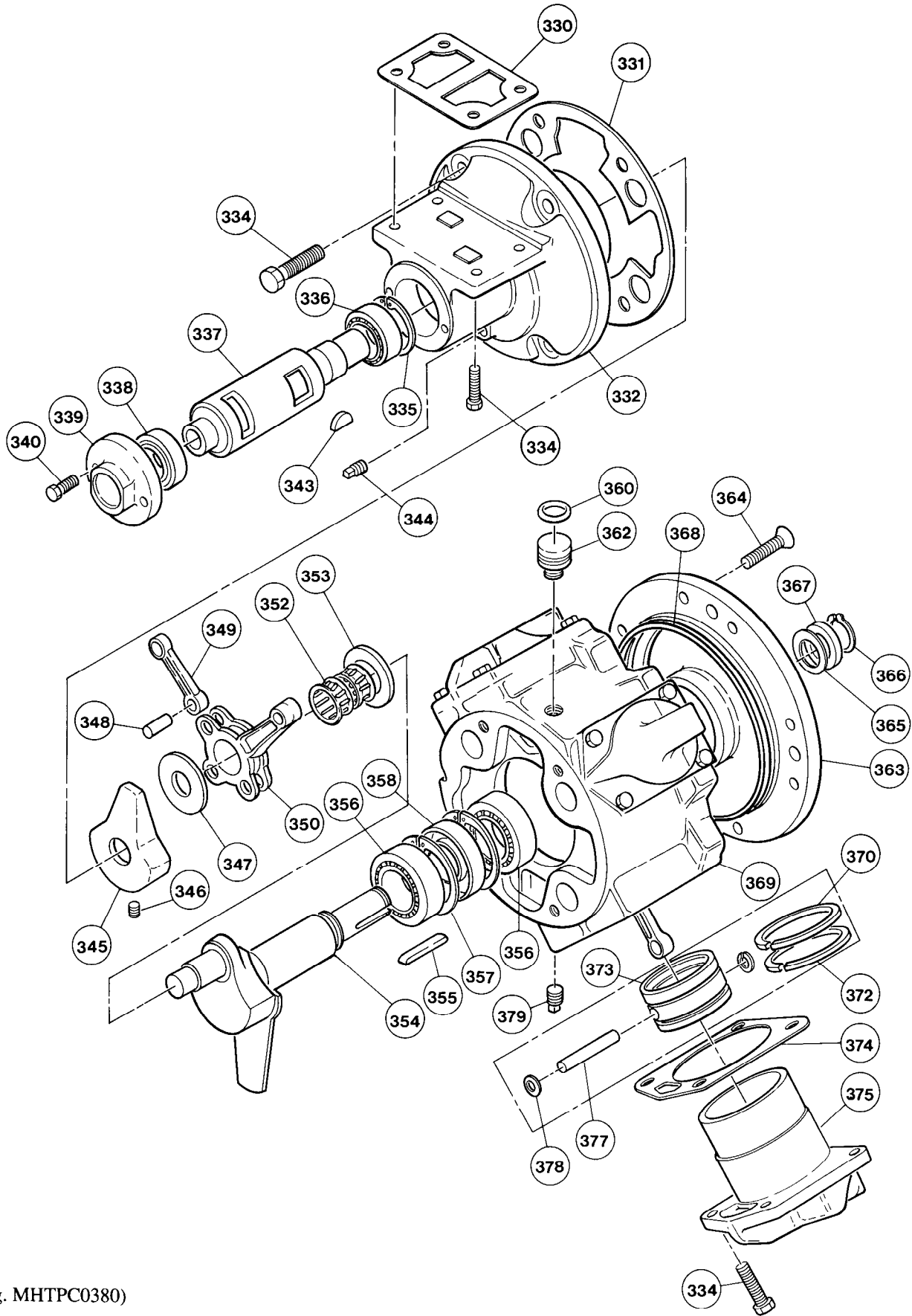

(Dwg. MHTPC0380)

## POWER HEAD PISTON MOTOR ASSEMBLY PARTS LIST

ITEM NO.	DESCRIPTION OF PART	QTY TOTAL	PART NO.
328	Motor Assembly (Incl's items 330 thru 379)	1	52154
• 330	Gasket	1	71018477
• 331	Gasket	1	71018485
332	Rotary Valve Housing	1	71028260
334	Capscrew	4	71030118
335	Retainer Ring	1	71028328
• 336	Bearing	1	71028310
337	Rotary Valve	1	71025589
• 338	Bearing	1	71028237
339	Cover	1	71029862
340	Capscrew	2	71030134
343	Key	1	71030076
344	Pipe Plug (Steel)	1	54658
	Pipe Plug (Brass)		71112247
345	Balance Weight	1	71030050
346	Setscrew	1	71030217
347	Spacer 0.098 in (2.5 mm)	1	71029987
	Spacer 0.118 in (3 mm)	2	71030019
	Spacer 0.138 in (3.5 mm)		71030035
348	Rod Pivot	3	71029953
349	Connecting Rod	3	71029961
350	Crank	1	71029565
• 352	Bearing	1	71030191
353	Spacer	1	71029581

ITEM NO.	DESCRIPTION OF PART	QTY TOTAL	PART NO.
354	Crank Shaft Assembly	1	71029672
355	Key	1	71030233
• 356	Bearing	2	71029912
357	Retainer Ring	2	71029656
• 358	Seal	1	71018535
360	'O' Ring (Shipping Only)	1	Not sold separately
362	Breather Plug	1	71030175
363	Flange Plate	1	71029698
364	Screw	4	71029888
• 365	Shim	5	71029649
366	Retainer Ring	1	71029607
367	Spacer	1	71029623
• 368	'O' Ring	1	71029714
369	Motor Housing	1	Order item 328
• 370	Oil Ring	4	71018519
• 372	Compression Ring	4	71018501
373	Piston Assembly (Incl's items 370, 372, 377 and 378)	4	71025563
• 374	Gasket	4	71018493
375	Cylinder	4	71025571
376	Capscrew	16	71030092
377	Pin	4	Order item 373
378	Retainer Ring	8	Order item 373
379	Pipe Plug	1	71029821

• Recommended spare



# BOTTOM BLOCK ASSEMBLY PARTS DRAWINGS

20 ton

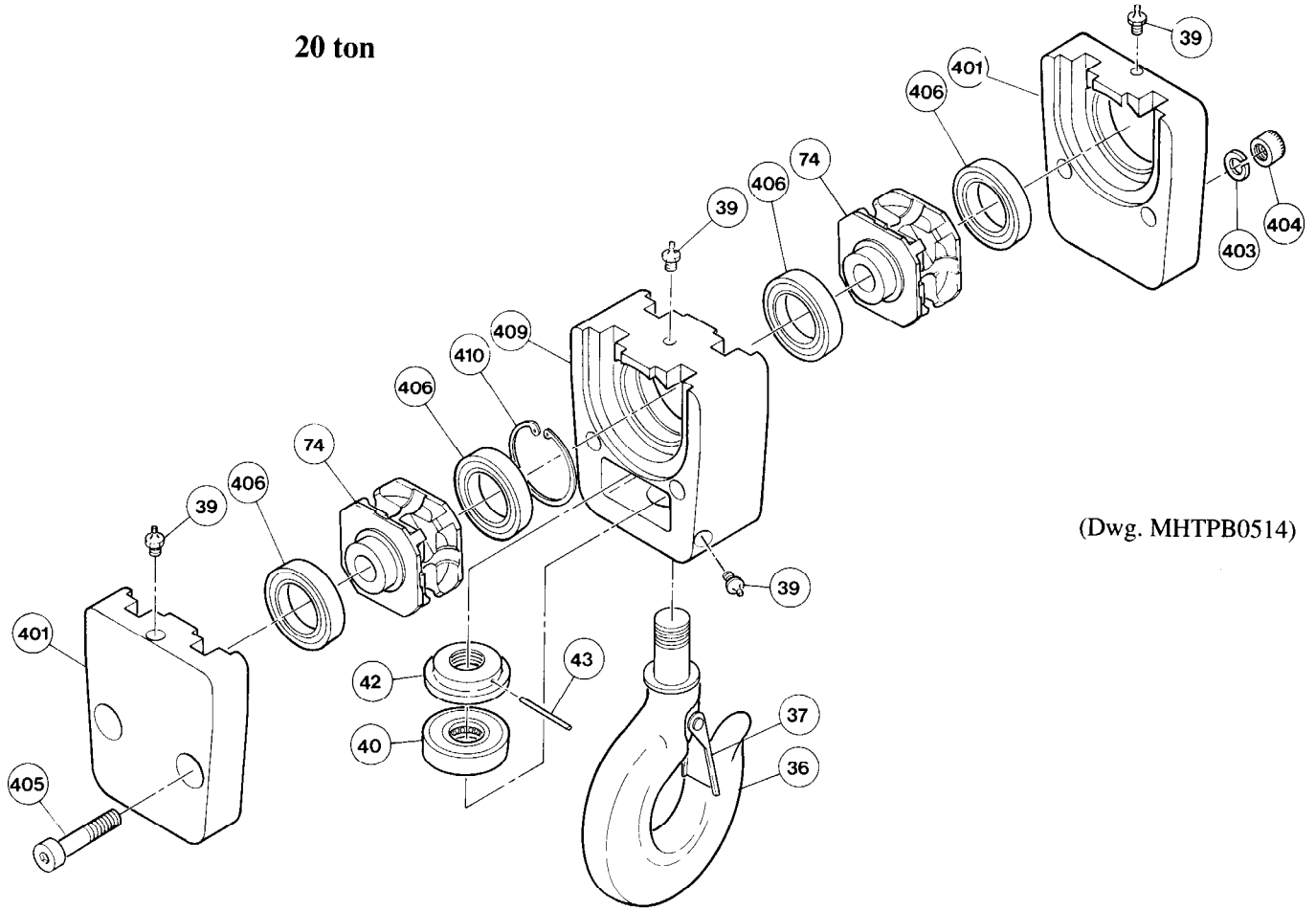

(Dwg. MHTPB0514)

15 ton

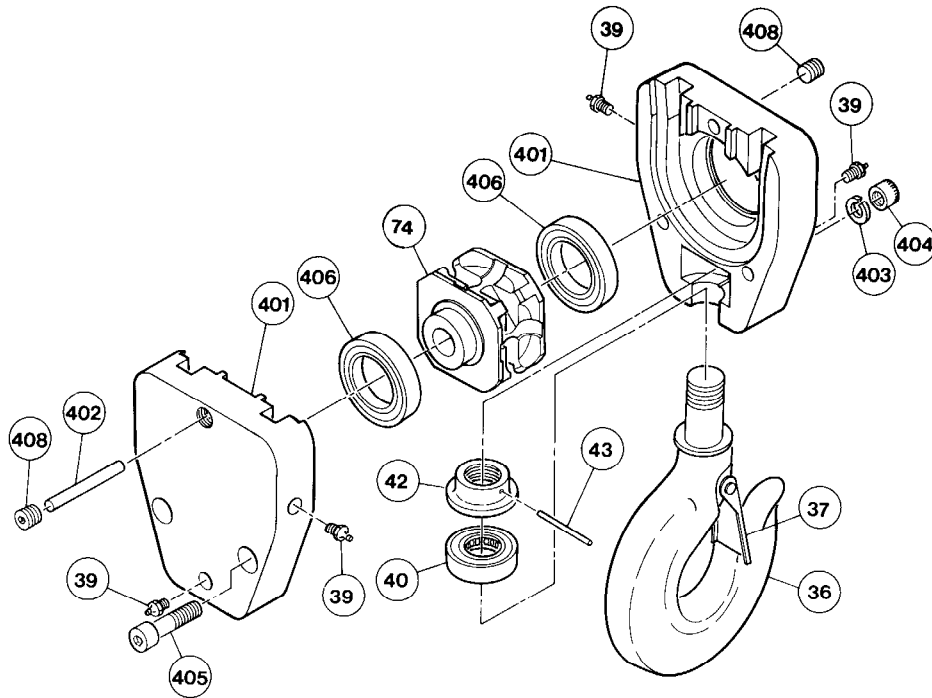

(Dwg. MHTPA0513)

## BOTTOM BLOCK ASSEMBLY PARTS LIST

ITEM NO.	DESCRIPTION OF PART	QTY TOTAL	PART NO.			
			5 ton	10 ton	15 ton	20 ton
400	Bottom Block Assy	1	19152-1	19153-1	19154-1	19155-1
	Bottom Block Assy (Bronze)		19152-2	19153-2	19154-2	19155-2
	Bottom Block Assy (Copper Plate)		19152-3	19153-3	19154-3	19155-3
36	Hook (Incl's item 37)	1	9569	8474-3	9079-1	13702
	Hook Copper Plate (Incl's item 37)		18838	18839	18840	18841
	Hook Solid Bronze (Incl's item 37)		18036	8937-1	16072	19431
• 37	Hook Latch Kit	1	51202	50597	50779	52173
	Hook Latch Kit (Bronze)		50597		52894	71054803
39	Grease Fitting	See ( )	51753 (1)	51753 (2)	53095 (4)	51753 (4)
39A	Grease Fitting		---	53477 (2)	---	---
• 40	Bearing	1	52291	50144	50468	50394
42	Nut	1	9571	8476	9081	8827
43	Pin	1	52311	50917		50958
74	Idler Sheave	See ( )	---	B-10068 (1)	B-10104 (1)	B-10068 (2)
401	Side Block	1 pair	9572-SET	B-10089-SET	B-10106	B-10065-SET
402	Pin	1	9453-5	---	9453-4	---
403	Lockwasher	2	54083	53477	53437	54953
404	Nut	2	52313	51752		50951
405	Capscrew	2	50910	51781	51778	51772
• 406	Bearing	2	---	50138	51585	50138
408	Plug	2	---	---	51782	---
409	Hook Center Block (included in side block set item 401)	1	---	---	---	*B-10065-2
410	Retainer Ring	1	---	---	---	51069

• Recommended Spare

\* Not available as a spare. Order item 401

**5 ton**

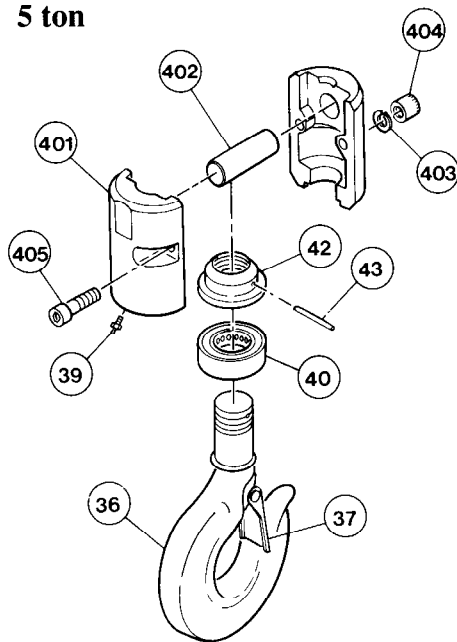

(Dwg. MHTPA0503)

**10 ton**

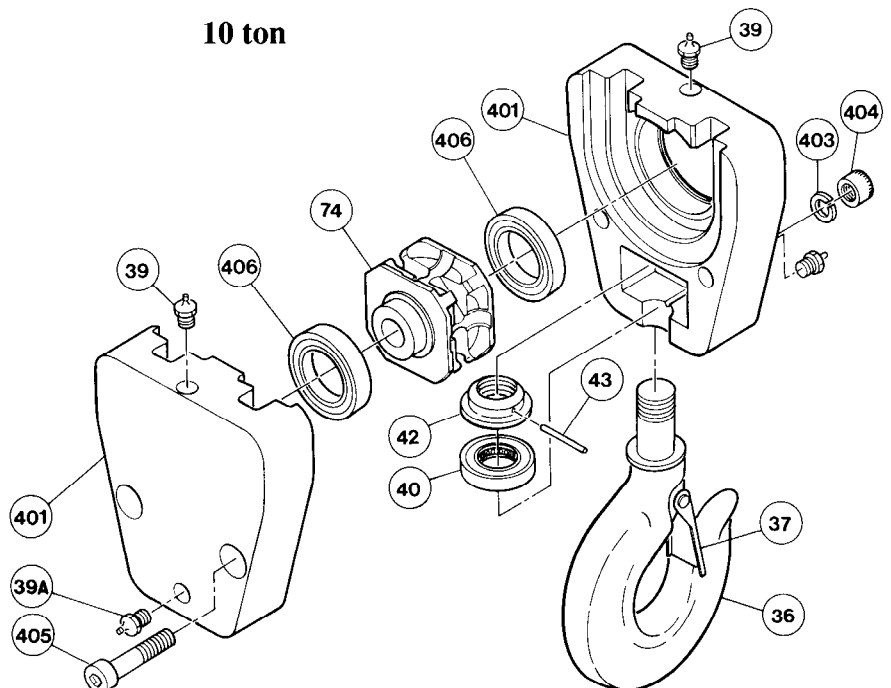

(Dwg. MHTPA0512)



## TROLLEY ASSEMBLY PARTS LIST

ITEM NO.	DESCRIPTION OF PART	QTY TOTAL	Part No.			
			5 ton	10 ton	15 ton	20 ton
39	Grease Fitting	4	53095			
71	Nameplate	1	71070098-R			
72	Drive Screw	4	50915			
150	Side Plate (Plain)	See ( )	18842		18844	18846
• 151	Oil Seal	4	51760		50539	50540
152	Retainer Ring	4	51764		51069	51045
153	Plain Wheel (Steel)	4*	8943-1		8212	8402
	Plain Wheel (Copper Plate)		19477		19478	19479
	Plain Wheel (Bronze)		8943-2		8212-1	8402-2
• 154	Bearing	4	51586		51066	50455
155	Spacer	4	54374		---	
156	Retainer Ring	4	51761		52355	51046
157	Spacer	See ( )	8424-5 (24)		8424-6 (48)	8424-7 (44)
158	Capscrew	4	50829			
159	Washer	4	50177			
160	Bumper	4	51722			
162	Capscrew	2	51763		51876	51036
164	Nut	2	51750			
165	Pin	4	70709**			
166	Roller	4	70712**			
167	Spacer/Washer	See ( )	52915 (4)			8439 (8)
169	Lockwasher	8	50203			
170	Capscrew	8	50850			
171	Roller Guide	4	21908**			
172	Gear Wheel (Steel)	2	8944-1		8234	8403
	Gear Wheel (Copper Plate)		19480		19481	19482
	Gear Wheel (Bronze)		8944-2		8234-1	8403-1
173	Side Plate (Geared Handwheel)	1	18843		19087	19142
	Side Plate (Motorized)		18969		18845	18847
174	Suspension Shaft (6-8 in.) Std.	2	9910-2		9914	10459-1
	Suspension Shaft (8-10 in.)		18971		19093	10459-2
	Suspension Shaft (10-12 in.)		19151		19846	10459-3
	Suspension Shaft (12-14 in.)		20309		23126	10459-4
175	Spacer	See ( )	18135-1 (4)		18336-1 (6)	---
176	Spacer	2	18135-2		18336	17853
177	Pin	2	8328-3		8328-6	8328-8
178	Pin, Cotter	2	51937			50157
179	Retainer Ring	1	71684			
285	Spacer	2	10414			
286	Bushing	2	50508			
287	Pinion Extension	1	15022			
288	Washer	1	50166			
289	Retainer Ring	2	52258			
290	Handwheel	1	70763			
292	Washer	1	70876			
293	Nut	1	71701			
294	Pin	1	71100			
295	Bushing	2	2982-2			
296	Chain	(1) Specify lift length	HCCF005			
	Chain Zinc Plated		HCCF005ZP			

\*\* Not available as replacement parts order kit 18975-1

Guide Rollers and End Bumpers are optional assemblies which do not come standard with the trolley.

• Recommended Spare

\* Geared/Motorized trolleys require quantity (2) plain wheels

# TROLLEY DRIVE ASSEMBLY PARTS DRAWING

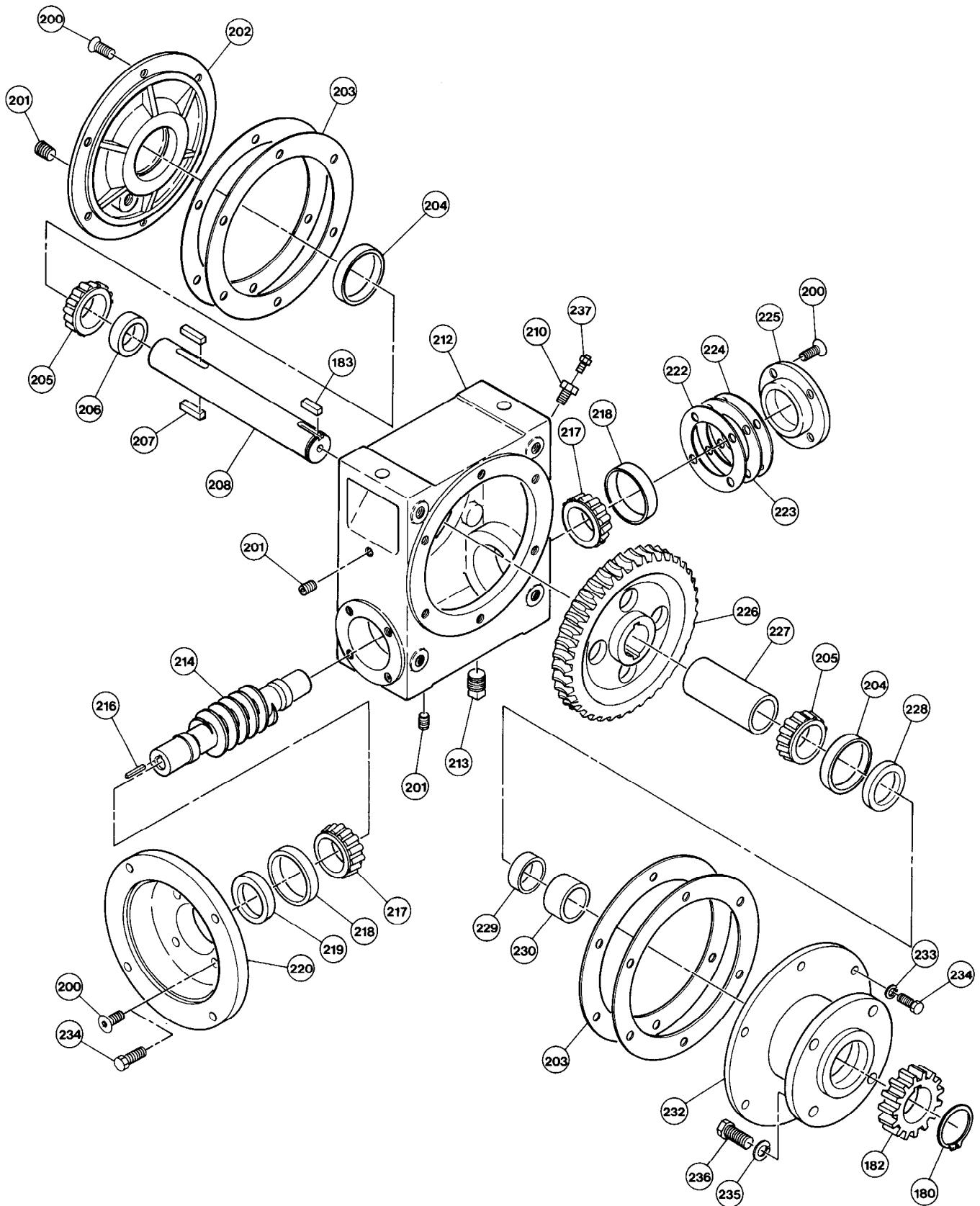

(Dwg. MHTPC0551)

## TROLLEY DRIVE ASSEMBLY PARTS LIST

ITEM NO.	DESCRIPTION OF PART	QTY TOTAL	PART NO.	
			PISTON MOTOR	VANE MOTOR
180	Retainer Ring	1	52645	51192
182	Drive Gear (5 ton)	1	18661	
	Drive Gear (10, 15 and 20 ton)		17690	
183	Key	1	19523-075	
200	Screw	14	51596	
201	Pipe Plug	3	51599	
202	Cover	1	3117	
• 203	Gasket (set)	2 (sets)	3118	
204	Bearing (Cup)	2	Order Bearing Assembly 71073407	
205	Bearing (Cone)			
206	Spacer	1	4147	
207	Key	2	3667	
208	Shaft	1	3112-2B	
210	Fitting, Bushing	1	51803	
212	Housing	1	B-5060	
213	Pipe Plug	1	51600	
214	Worm	1	11291	3829
216	Key	1	50273	
217	Bearing (Cone)	2	Order Bearing Assembly 71073415	
218	Bearing (Cup)			
• 219	Oil Seal	1	51283	
220	Motor Adapter	2	11252	6553
222	Shim 0.007 in. (0.178 mm)	3	Order Shim Kit 6550-50	
223	Shim 0.005 in. (0.127 mm)	3		
224	Shim 0.020 in. (0.508 mm)	1		
225	Cover	1	3115	
226	Worm Gear	1	3830	
227	Spacer	1	4147-1	
• 228	Oil Seal	1	51578	
229	Sleeve	1	3114	
230	Spacer	1	4147-9	
232	Reducer Adapter	1	8333-2	
233	Lockwasher	6	50200	
234	Capscrew	See ( )	51597 (6)	51597 (6)
235	Lockwasher	4	50181	
236	Capscrew	4	50827	
237	Breather	1	52024	
238	Pipe Plug	1	54912	
239	Washer	4	50182	
• ---	Trolley Drive Repair Kit (incl's items 203, 204, 205, 217, 218, 222, 223, 224 and 228)	1	HA1-TGSK	

• Recommended spare



## TROLLEY DRIVE PISTON MOTOR ASSEMBLY PARTS LIST

ITEM NO.	DESCRIPTION OF PART	QTY TOTAL	PART NO.
329	Motor Assembly (Incl's items 330 thru 379)	1	52151
28	Pipe Plug (steel)	1	54658
	Pipe Plug (brass)		71112247
• 330	Gasket	1	71018386
• 331	Gasket	1	71018394
332	Rotary Valve Housing	1	71028252
334	Capscrew	24	71030084
335	Retainer Ring	1	71028328
• 336	Bearing	1	71028310
337	Rotary Valve	1	71028245
• 338	Bearing	1	71028237
339	Cover	1	71029854
340	Capscrew	2	71028518
343	Key	1	71030068
345	Balance Weight	1	71030043
346	Setscrew	1	71030209
347	Spacer 0.060 in. (1.5 mm)	2	71029979
	Spacer 0.010 in. (0.25 mm)		71029995
	Spacer 0.075 in. (1.9 mm)		71030001
	Spacer 0.105 in. (2.7 mm)		71030027
349	Connecting Rod	4	71029896
351	Ring	2	71029946
• 352	Bearing	1	71030183

ITEM NO.	DESCRIPTION OF PART	QTY TOTAL	PART NO.
353	Spacer	1	71029573
354	Crankshaft	1	71029664
355	Key	1	71030225
• 356	Bearing	2	71029904
• 358	Seal	1	71018444
360	'O' Ring (Shipping Only)	1	Not sold separately
362	Breather Plug	1	71030175
363	Flange Plate	1	71029680
364	Screw	4	71029870
365	Shim	5	71029631
366	Retainer Ring	1	71029599
367	Spacer	1	71029615
• 368	'O' Ring	1	71029706
369	Motor Housing	1	Order item 329
• 370	Oil Ring	4	71018428
• 372	Compression Ring	4	71018410
373	Piston Assembly (Incl's items 370, 372, 377 and 378)	4	71029557
• 374	Gasket	4	71018402
375	Cylinder	4	71028336
377	Wrist Pin	4	Order item 373
378	Retainer Ring	8	Order item 373
379	Pipe Plug	1	71029722

• Recommended spare



# TROLLEY DRIVE VANE MOTOR ASSEMBLY PARTS DRAWING

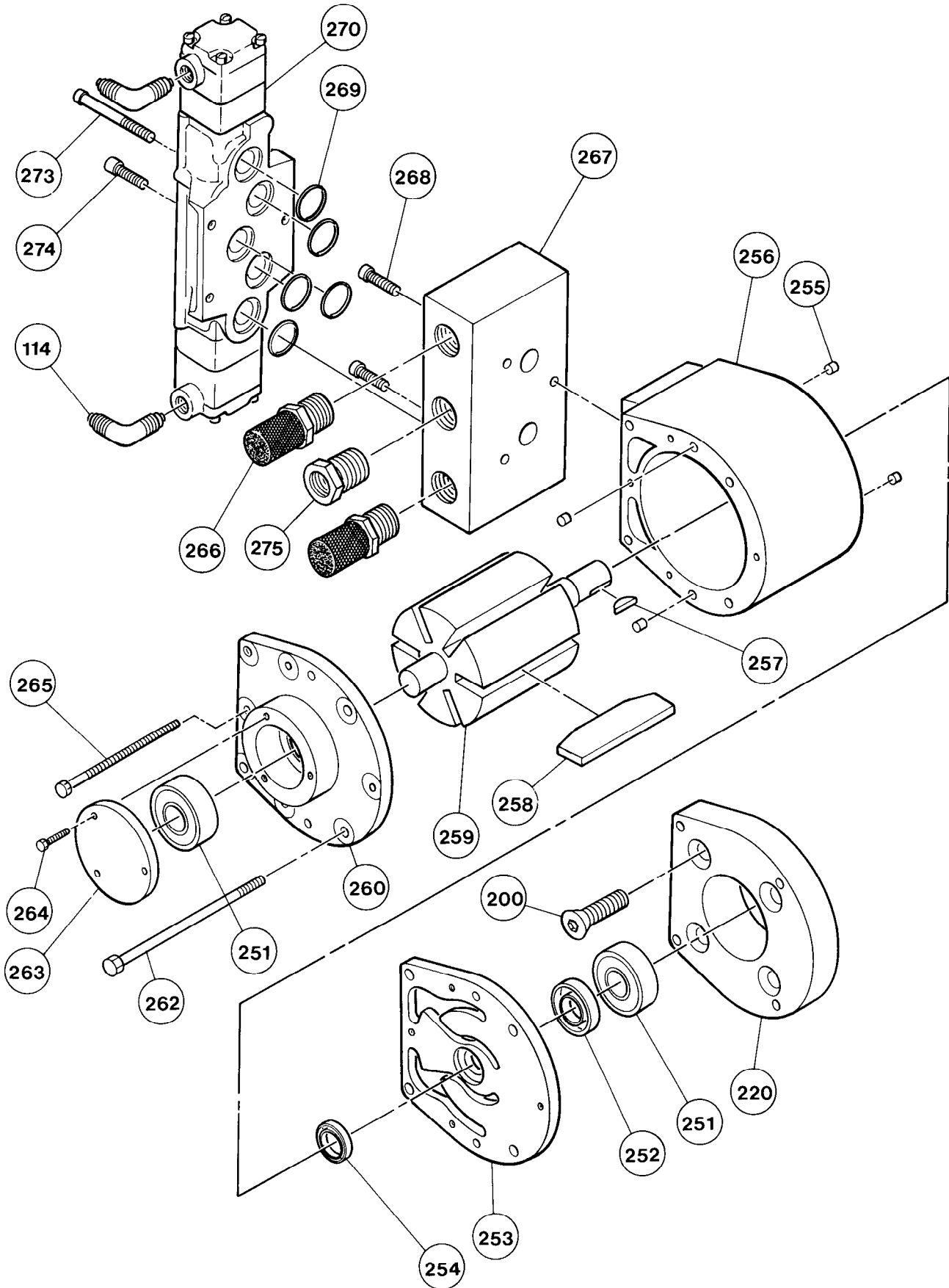

(Dwg. MHTPB0379)

## TROLLEY DRIVE VANE MOTOR ASSEMBLY PARTS LIST

ITEM NO.	DESCRIPTION OF PART	QTY TOTAL	PART NO.
199	Motor Assembly (Incl's items 251 thru 265)	1	4864
114	Fitting	2	51281
200	Screw	2	51596
220	Motor Adapter	1	6553
• 251	<b>Bearing</b>	2	<b>51074</b>
• 252	<b>Seal</b>	1	<b>50840</b>
253	Cover	1	6554
• 254	<b>Seal</b>	1	<b>51591</b>
255	Dowel	4	51084
256	Cylinder	1	3131
257	Shaft Key	1	50273
• 258	<b>Vane</b>	<b>1 kit</b>	<b>(4335-6) Order kit 1000P60-VMK</b>
259	Shaft and Rotor	1	4333-A
260	Cover	1	3761
262	Capscrew	4	51080
263	Cap	1	4334
264	Capscrew	3	51081
265	Capscrew	4	51078
266	Muffler	2	50593
267	Valve Manifold	1	8466
268	Capscrew	2	51095
• 269	<b>'O' Ring</b>	<b>5</b>	<b>P-1100-13</b>
270	Pilot Control Valve	1	50431
273	Capscrew	1	51079
274	Capscrew	2	
275	Fitting	1	54913
---	Repair Kit (Incl's items 251, 252, 254, 258, 262, 264 and 265)	As Req'd	1000P60-VMK

•   Recommended Spare

The vane motor is an optional component which can be used in place of the standard piston motor (329)

# VANE MOTOR VALVE ASSEMBLY DRAWING AND PARTS LIST

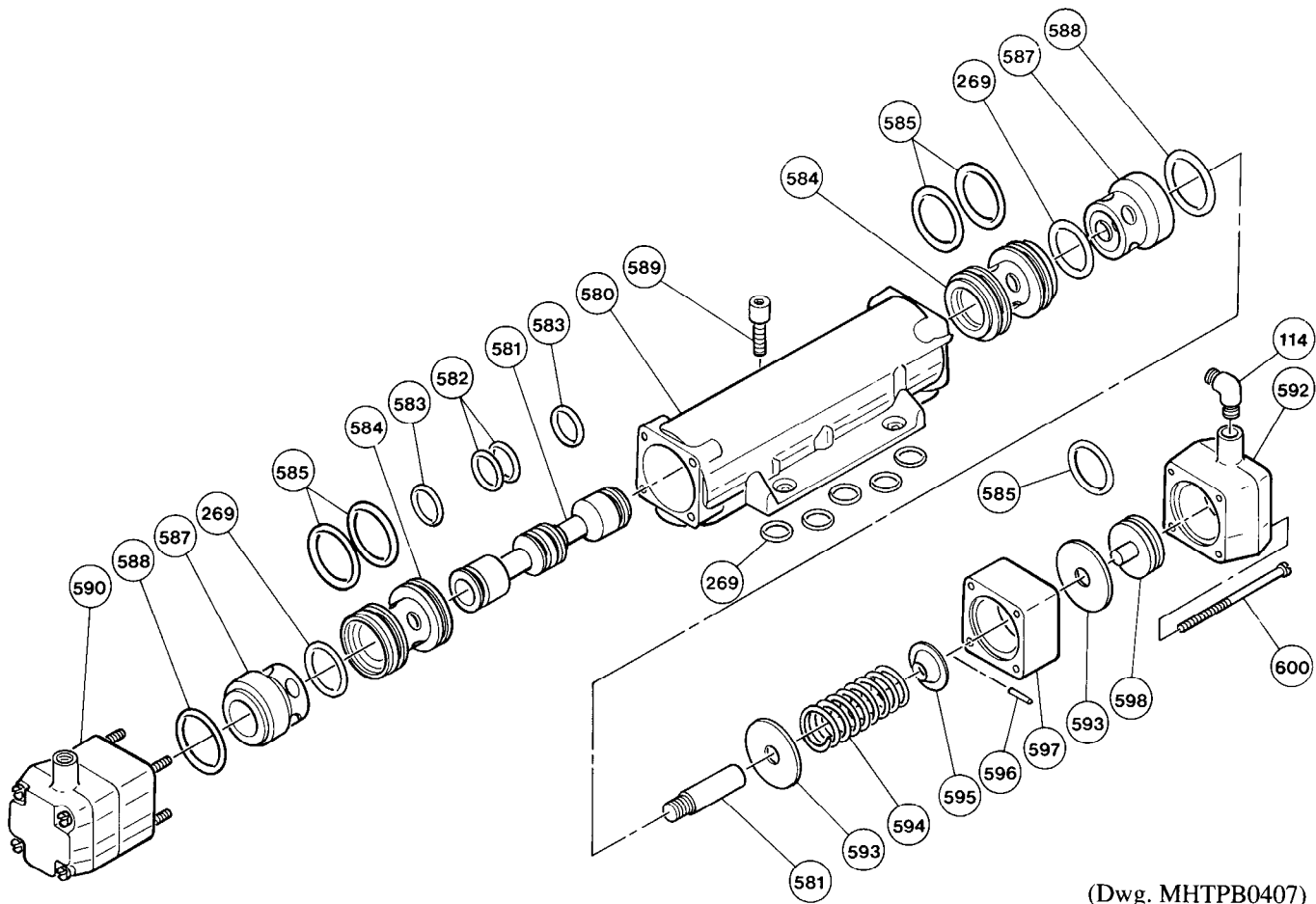

(Dwg. MHTPB0407)

ITEM NO.	DESCRIPTION OF PART	QTY TOTAL	PART NO.	ITEM NO.	DESCRIPTION OF PART	QTY TOTAL	PART NO.
270	Pilot Control Valve (Incl's items 114, 269 and 580 thru 600)	1	50431	589	Capscrew	1	71128748
114	Fitting	2	51281	590	Spring Center Cap Assembly	1	71128755
• 269	'O' Ring	7	P-1100-13	592	Pilot Cap	2	71128763
580	Body	1	Order item 270	593	Washer	4	71128771
581	Plunger	1	71060198	594	Spring	2	71060206
• 582	'O' Ring	2	P-1100-10	595	Spring Cap	2	71064604
• 583	'O' Ring	2	P-1000-10	596	Pin	2	71064596
584	Bushing	2	71128722	597	Pilot Spacer	2	71128789
• 585	'O' Ring	6	P-1000-17	598	Piston	2	71128797
587	Retainer	2	71128730	600	Screw	8	71128805
• 588	'O' Ring	2	P-1000-19				

• Recommended spare

# CHAIN BUCKET ASSEMBLY DRAWINGS AND PARTS LIST

## Hook Mount

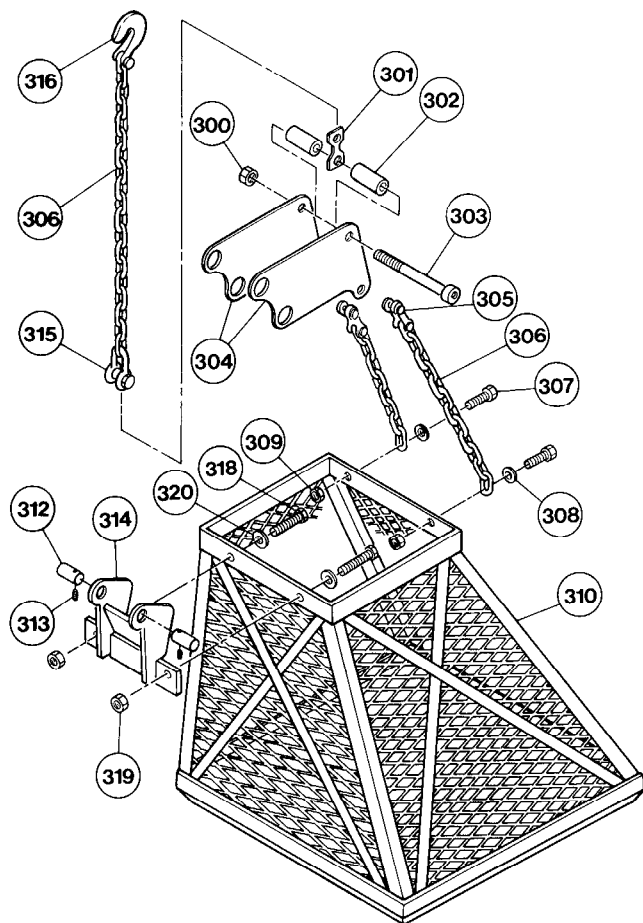

(Dwg. MHTPA0518)

## Trolley Mount

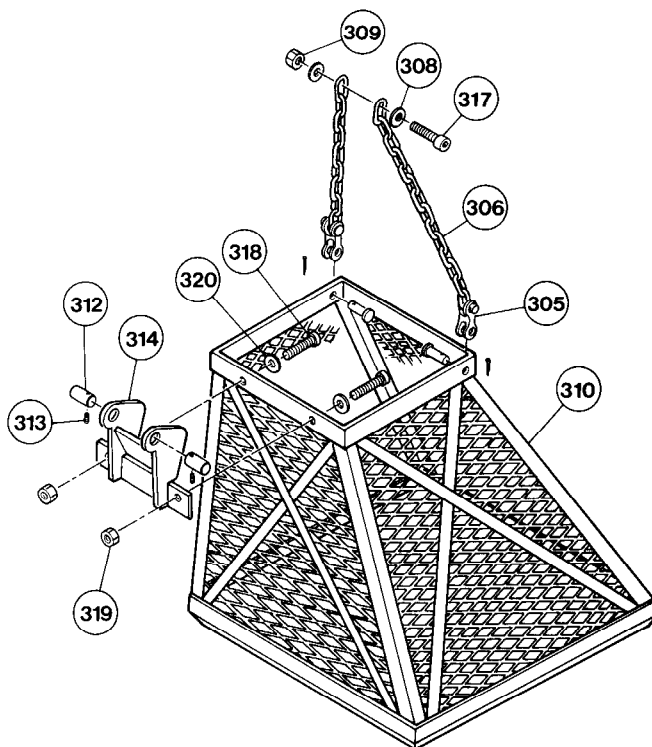

(Dwg. MHTPA0517)

ITEM NO.	DESCRIPTION OF PART	QTY TOTAL	PART NO.	ITEM NO.	DESCRIPTION OF PART	QTY TOTAL	PART NO.
300	Nut	1	51750	309	Nut	1 Trolley Mount 2 Hook Mount	50170
301	Tension Link (5 ton)	1	21620	310	Chain Bucket	1	20512-*
	Tension Link (10 ton)	2		312	Pin	2	9466-1
	Tension Link (15 & 20 ton)	3		313	Setscrew	2	51771
302	Spacer (5, 10 and 15 ton)	2	23435-200	314	Bracket (5, 10 and 15 ton)	1	20514
	Spacer (20 ton)		23435-425		Bracket (20 ton)		20518
303	Capscrew (5, 10 & 15 ton)	1	71098073	315	Shackle	1	71098099
	Capscrew (20 ton)		71098537	316	Hook	1	71098081
304	Bracket	2	21599	317	Capscrew	1	51769
305	Clevis	2	54645	318	Capscrew	2	54240
306	Chain	Specify Length	50962	319	Nut	2	71061584
307	Capscrew	2	50847	320	Washer	2	54650
308	Washer	2	51833				

\* Specify hoist capacity and length of load chain lift.

# LIMIT SWITCH ASSEMBLY PARTS DRAWING

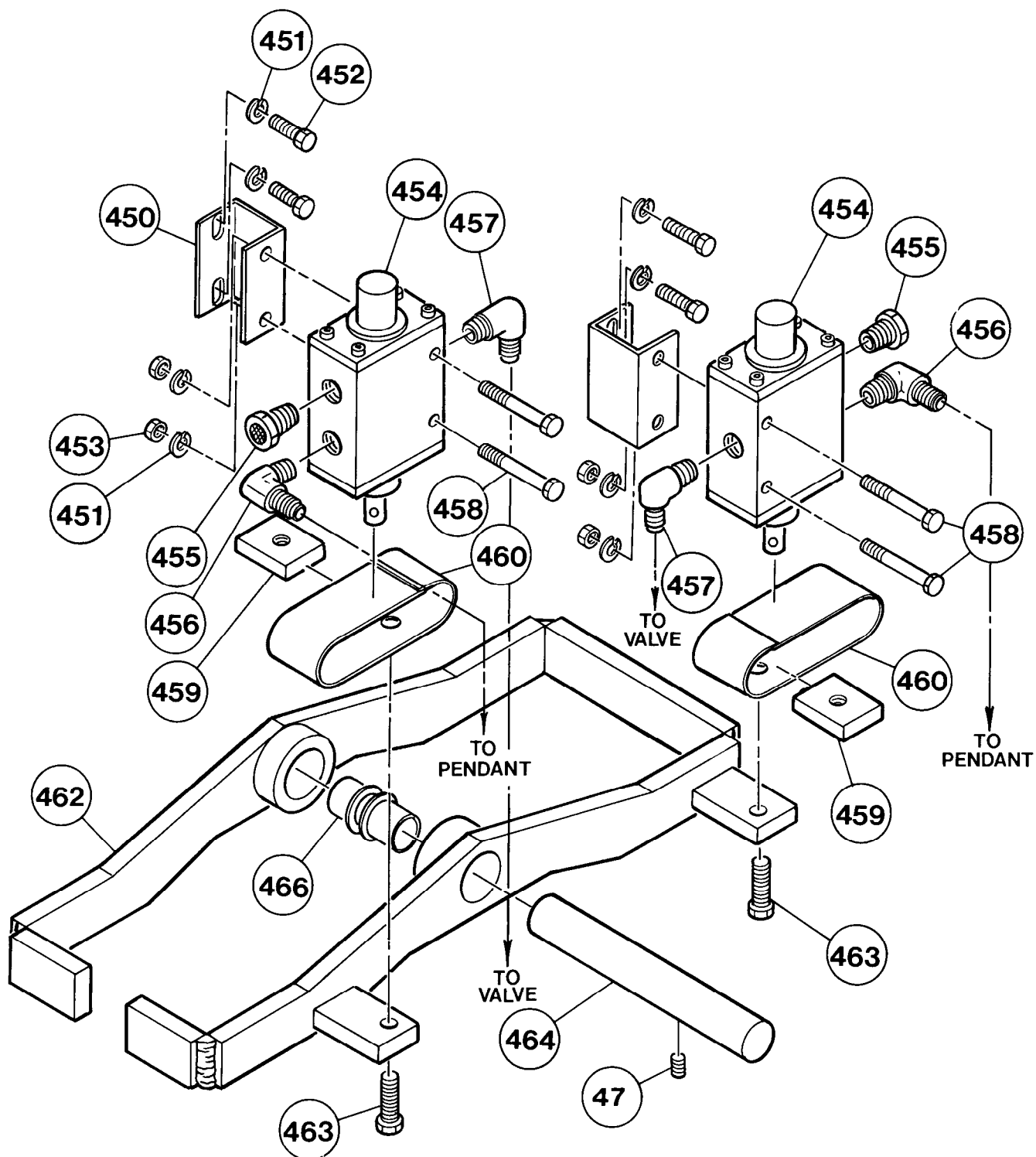

Limit Arm (462) shown is for 5 and 10 ton hoists. Design varies for 15 and 20 ton hoists.

(Dwg. MHTPA0526)

## LIMIT SWITCH ASSEMBLY PARTS LIST

ITEM NO.	DESCRIPTION OF PART	QTY TOTAL	PART NO.			
			5 ton	10 ton	15 ton	20 ton
47	Setscrew	See ( )	50975 (1)			71069074 (2)
450	Spacer	2	19271			
451	Lockwasher	8	51801			
452	Capscrew	4	54113			
453	Nut	4	53390			
454	Limit Switch	2	53040			
455	Breather	2	50595			
456	Vented Fitting	2	19628			
457	Fitting	2	51805			
458	Capscrew	4	54277			
459	Retainer	2	13051			
460	Spring	2	13049			
462	Limit Arm	1	9513		19267	9452
463	Capscrew	2	52263			
464	Shaft	1	9542			9451
• 466	Bushing	2	50146			
467	Washer	1	14600	---		
468*	Spacer	1	---			23434-063



Recommended Spare

\* Not shown on drawing

### Assembly Information:

Limit arm (462) attaches to chain stripper (45) with shaft (464). Spacer brackets (450) attach to reducer adapter (50) with capscrews (452) and lockwashers (451).

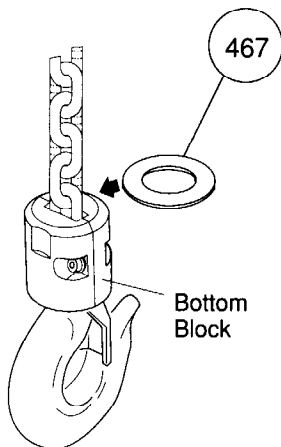

Item 467 washer is required on 5 ton units equipped with the limit switch option only. The washer is installed on the load chain and rests on top of the bottom block assembly. Refer to Dwg. MHTPA0539.

(Dwg. MHTPA0539)

# PIPING ASSEMBLY PARTS DRAWING

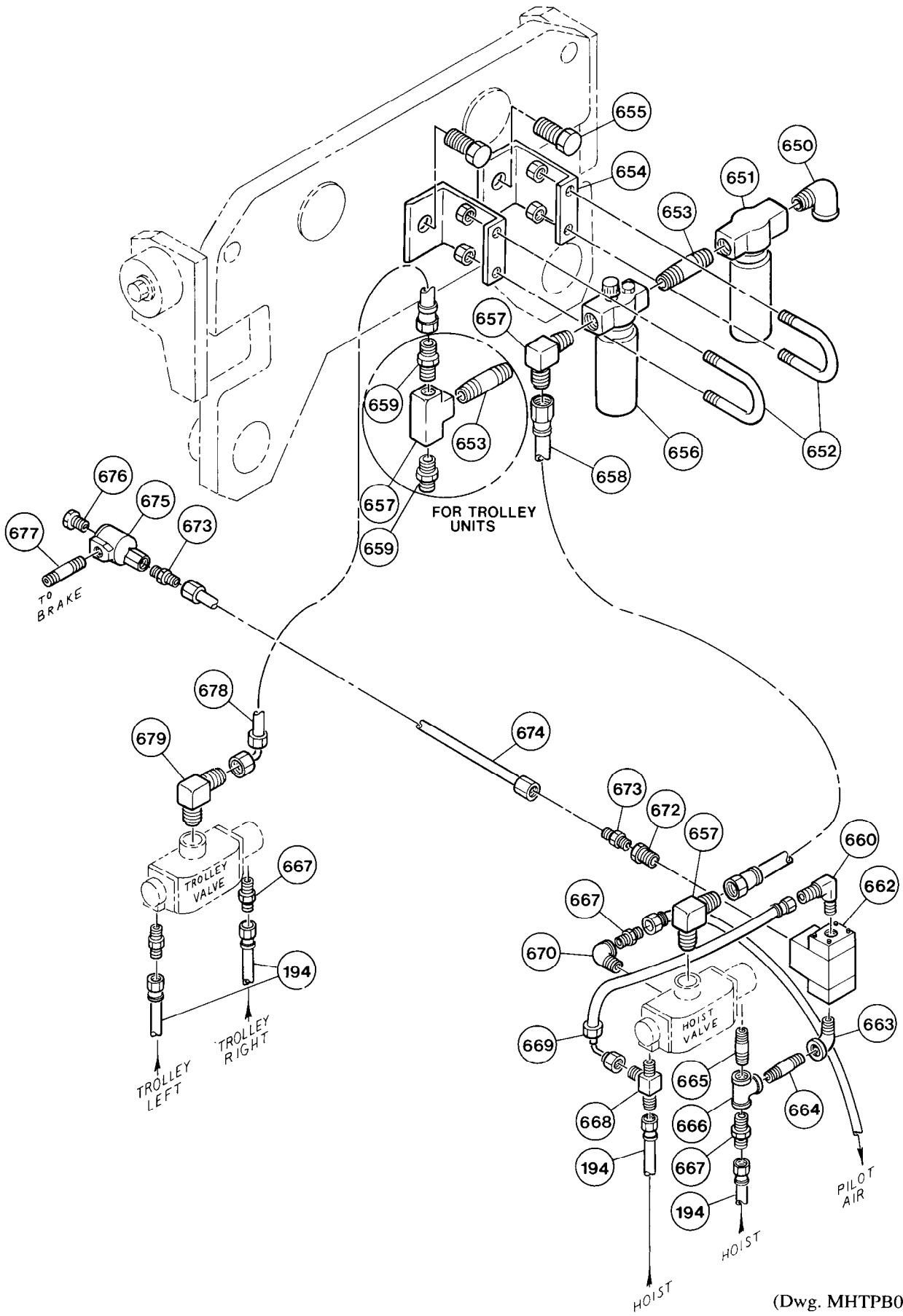

(Dwg. MHTPB0552)

## PIPING ASSEMBLY PARTS LIST

ITEM NO.	DESCRIPTION PART	OF	QTY TOTAL	PART NO.	
				Hoist without Trolley	Hoist with Trolley
194	Hose Assembly		As Req'd	See Hose Assembly Drawing and Parts List	
650	Fitting, Elbow		1	52190	
651	Filter		1	50225	
652	'U' Clamp		2	---	51681
653	Fitting, Nipple		See ( )	51056 (1)	51056 (2)
654	Bracket		2	---	8551-5
655	Capscrew		2	---	51837
656	Lubricator		1	52176	
657	Fitting, Elbow		See ( )	52180 (2)	---
	Fitting, Tee			---	54933 (1)
658	Hose Assembly		1	17597-1	51003
659	Fitting, Nipple		2	52185	
660	Fitting, Elbow		1	54869	
662	Shuttle Valve		1	50277	
663	Fitting, Elbow		1	52803	
664	Fitting, Nipple		1	50859	
665	Fitting, Nipple		1	51034	
666	Fitting, Tee		1	51812	
667	Fitting, Nipple		See ( )	51814 (1)	51814 (3)
668	Fitting, Tee		1	52181	
669	Hose Assembly		1	17073-6	
670	Fitting, Elbow		1		
672	Fitting, Bushing		1	54870	
673	Fitting, Nipple		1	52646	
674	Tube		2	52187	
675	Valve		1	50275	
676	Breather		1	50595	
677	Fitting, Nipple		1	52191	
678	Hose Assembly		1	---	17549-3
679	Fitting, Elbow		1	---	53462



# PENDANT ASSEMBLY PARTS DRAWING

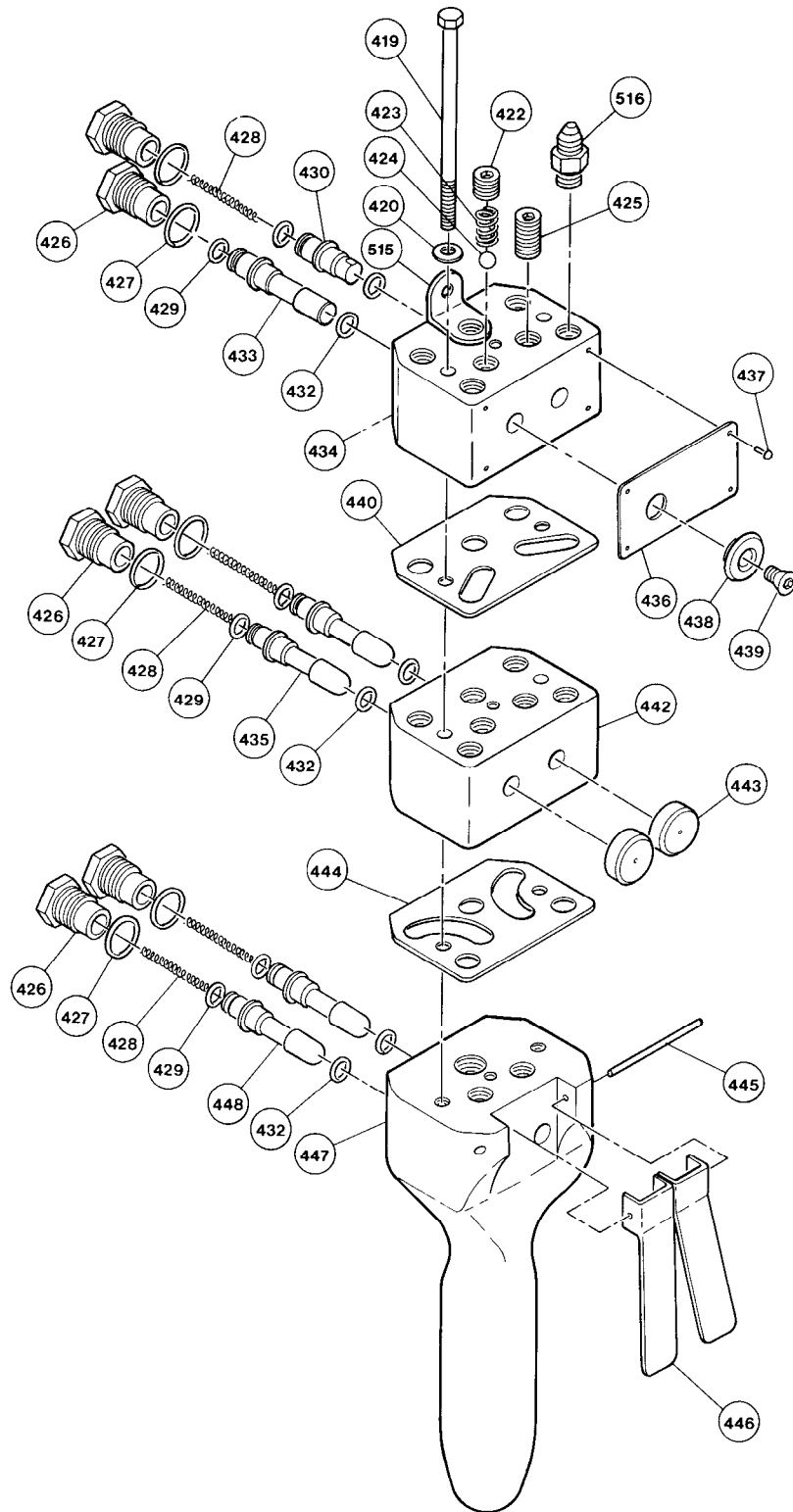

(Dwg. MHTPA0396)

## PENDANT ASSEMBLY PARTS LIST

ITEM NO.	DESCRIPTION OF PART	QTY TOTAL	PART NO.			
			2 Button	4 Button	2 Button w/emerg off	4 Button w/emerg off
417	Pendant Assembly (Standard)	1	---	51412	18952	18956
	Pendant Assembly Marine (Anodized)		21685	19755	15003-1	15002-1
419	Capscrew	2	---	51675		51679
420	Washer	2	---	51676		
422	Screw	1	---	51674		
• 423	<b>Spring</b>	1	---	<b>51414</b>		
424	Ball	1	---	51552		
425	Pipe Plug	1	51677			
426	Cap	See ( )	9486 (2)	9486 (4)		9486 (6)
• 427	<b>'O' Ring</b>	<b>See ( )</b>	<b>51233 (2)</b>	<b>51233 (4)</b>		<b>51233 (6)</b>
• 428	<b>Spring</b>	<b>See ( )</b>	<b>51235 (2)</b>	<b>51235 (4)</b>	<b>51235 (3)</b>	<b>51235 (5)</b>
• 429	<b>'O' Ring</b>	<b>See ( )</b>	<b>50846 (2)</b>	<b>50846 (4)</b>		<b>50846 (6)</b>
430	Spool (Emergency Off)	1	---	---		9071-4
• 432	<b>'O' Ring</b>	<b>See ( )</b>	<b>51234 (2)</b>	<b>51234 (4)</b>		<b>51234 (6)</b>
433	Spool (Emergency Off)	1	---	9071-2		
434	Block (Emergency Off)	1	---	9984	9424	
435	Spool (Trolley)	2	---	9071-3	---	9071-3
436	Nameplate	1	---	9436		
437	Drive Screw	4	---	51673		
438	Emergency Off Button	1	---	9414		
439	Capscrew	1	---	51672		
• 440	<b>Gasket</b>		---	<b>9854</b>		
442	Block (Trolley)	1	---	51678	---	51678
443	Button (Trolley)	2	---	9414-1	---	9414-1
• 444	<b>Gasket</b>	1	---	<b>9852</b>	---	<b>9852</b>
445	Pin	1	51671			
446	Lever	2	51413			
447	Pendant Handle	1	Order Pendant Assembly item 417		52481	
448	Spool (Hoist)	2	9071-1			
515	Bracket	1	8909			
516	Fitting	See ( )	52092 (4)	52092 (5)	52092 (4)	52092 (6)

• Recommended Spare

2 Button Pendant provides hoist control only

4 Button Pendant provides hoist and trolley control only

Emergency Off feature can be used with the 2 button or 4 button pendant

# PISTON MOTOR VALVE ASSEMBLY DRAWING AND PARTS LIST

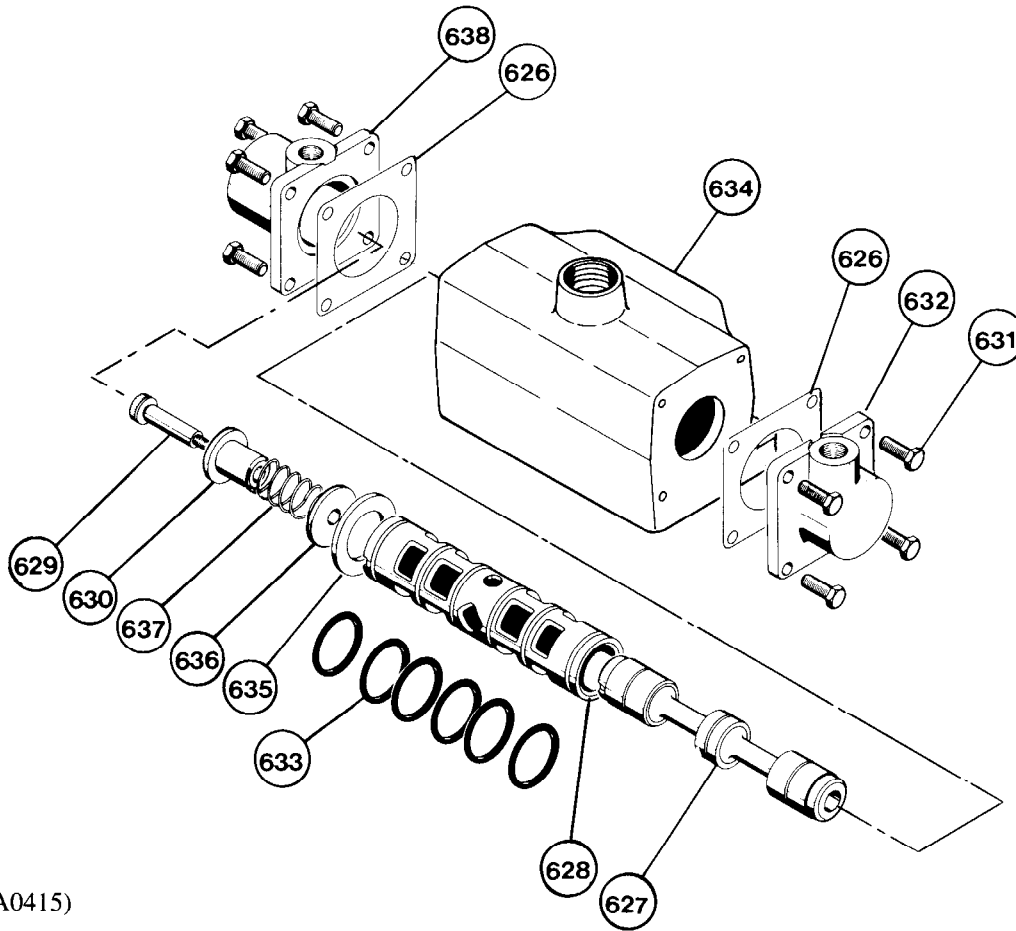

(Dwg. MHTPA0415)

ITEM NO.	DESCRIPTION OF PART	QTY TOTAL	PART NO.
625	Valve Assembly (Incl's items 626 thru 638)	1	51700
• 626	End Cap Gasket	2	51978
627	Valve Spool	1	Order Complete Valve Assembly item 625
628	Valve Sleeve	1	
629	Shoulder Screw	1	71128631
630	Centering Shaft Guide	1	54918
631	Capscrew	8	71028518
632	End Cap	1	54920
• 633	'O' Ring	6	51632
634	Valve Body	1	Order Complete Valve Assembly item 625
635	Spacer	1	54923
636	Washer	1	54924
637	Spring	1	54925
638	End Cap	1	54926

• Recommended Spare

# HOSE ASSEMBLY DRAWING AND PARTS LIST

ITEM NO.	DESCRIPTION OF PARTS	QTY TOTAL	PART NUMBER
*	Hose Assembly	*	See Hose Assembly Chart
188	Chain, Zinc Plated	As Req'd	50041
189	Tie Wrap	As Req'd	54235
190	Attachment Ring	As Req'd	50040
191	S-Hook	2	52120
192	Hose Fitting	As Req'd	51029
193	Adapter Fitting	As Req'd	71048268
194	Hose	As Req'd.	50923
• 195	Exhaust Valve Kit (Incl's items 192, 193 and 196)	As Req'd	20417
196	Adapter Fitting	As Req'd	71048284

• Recommended Spare

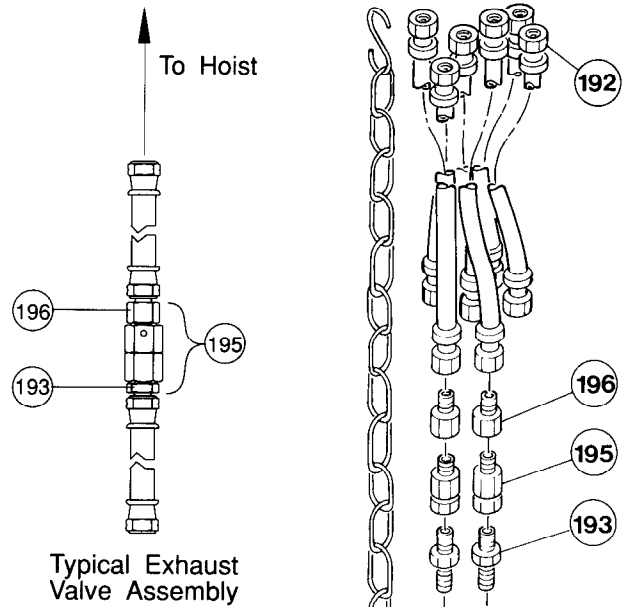

## Hose Assembly Parts List Chart

LENGTH		PART NUMBER (w/out EMERGENCY STOP)		
Feet	Meters	2 Button	4 Button	6 Button
10	3	21653-10	21654-10	21655-10
15	4.5	21653-15	21654-15	21655-15
20	6	21653-20	21654-20	21655-20
25	7.6	21653-25	21654-25	21655-25
30	9	21653-30	21654-30	21655-30
35	10.7	21653-35	21654-35	21655-35
40	12	21653-40	21654-40	21655-40
45	13.7	21653-45	21654-45	21655-45
50	15.25	21653-50	21654-50	21655-50

LENGTH		PART NUMBER (w/ EMERGENCY STOP)		
Feet	Meters	2 Button	4 Button	6 Button
10	3	21656-10	21657-10	21658-10
15	4.5	21656-15	21657-15	21658-15
20	6	21656-20	21657-20	21658-20
25	7.6	21656-25	21657-25	21658-25
30	9	21656-30	21657-30	21658-30
35	10.7	21656-35	21657-35	21658-35
40	12	21656-40	21657-40	21658-40
45	13.7	21656-45	21657-45	21658-45
50	15.25	21656-50	21657-50	21658-50

- Notes:**
1. Dump valves included on lengths of 10 ft. (3 m) and longer to provide quick exhaust and improve control response.
  2. For hose bundle lengths over 50 feet (15.25 meters) contact Technical Support Department for control acceptability.

(Dwg. MHTPA0425)

# PENDANT ASSEMBLY DRAWING AND PARTS LIST

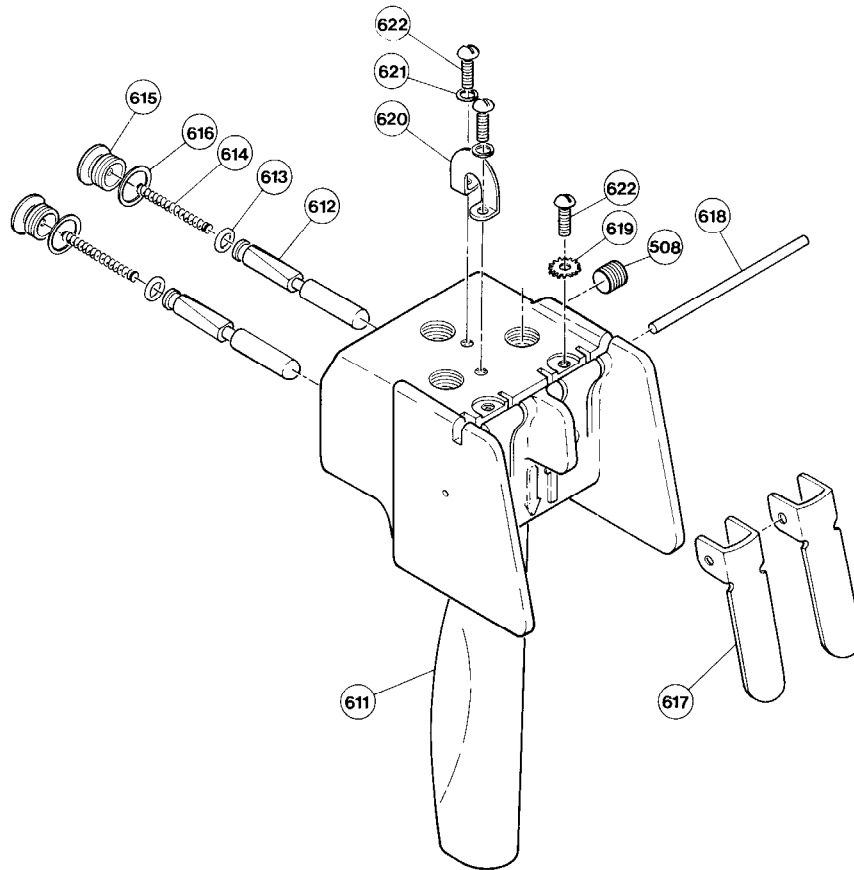

(Dwg. MHTPA0416)

ITEM NO.	DESCRIPTION OF PART	QTY TOTAL	PART NO.
610	Pendant Assembly (Incl's items 611 thru 622)	1	MLK-A269A
508	Pipe Plug	1	54247
611	Pendant Handle	1	Order complete pendant assembly item 610
612	Throttle Valve	2	MLK-K264A
613	Throttle Valve face	2	R000BR1C-283
• 614	<b>Throttle Valve Spring</b>	2	<b>MLK-51A</b>
615	Throttle Valve Cap	2	MLK-266A
• 616	<b>Valve Cap Gasket</b>	2	<b>MLK-504</b>
617	Throttle Valve Lever	2	MLK-273
618	Throttle Lever Pin	1	DLC-120A
619	Pin Lock Washer	2	D02-138
620	Strain Relief Support	1	MLK-450
621	Lockwasher	2	H54U-352
622	Handle Screw	4	HRE20A-68

• Recommended Spare

## LOAD CHAIN AND CHAIN STOPPER PARTS LIST

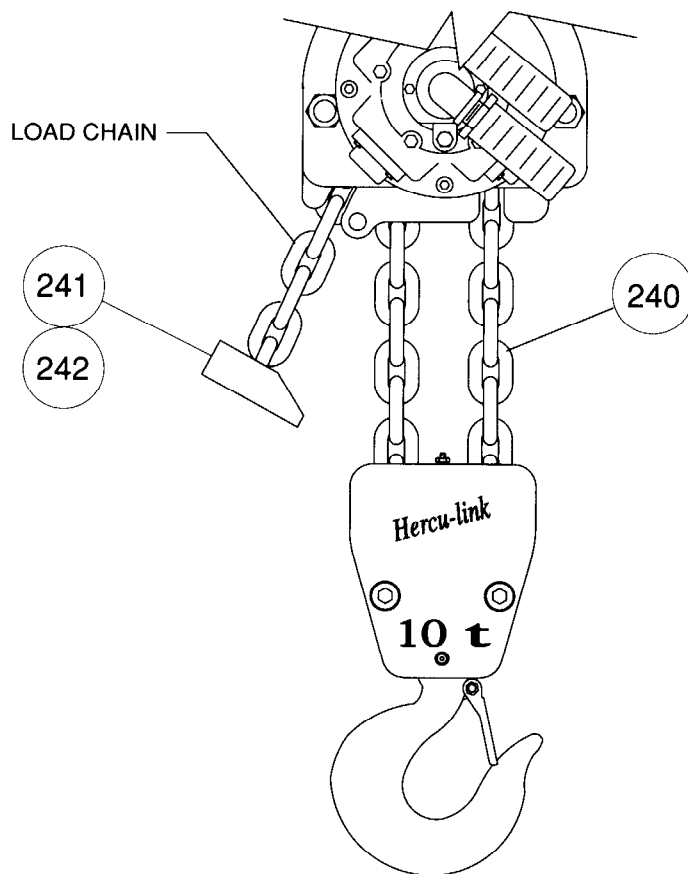

(Dwg. MHTPA0507)

ITEM NO.	DESCRIPTION OF PART	QTY TOTAL	PART NO.
240	Load Chain	(1) Specify Lift length	50227
	Load Chain (Zinc Plated)		17671
241	Chain Stopper	1	9573
242	Capscrew	1	51040

# ROPE CONTROL PARTS DRAWING

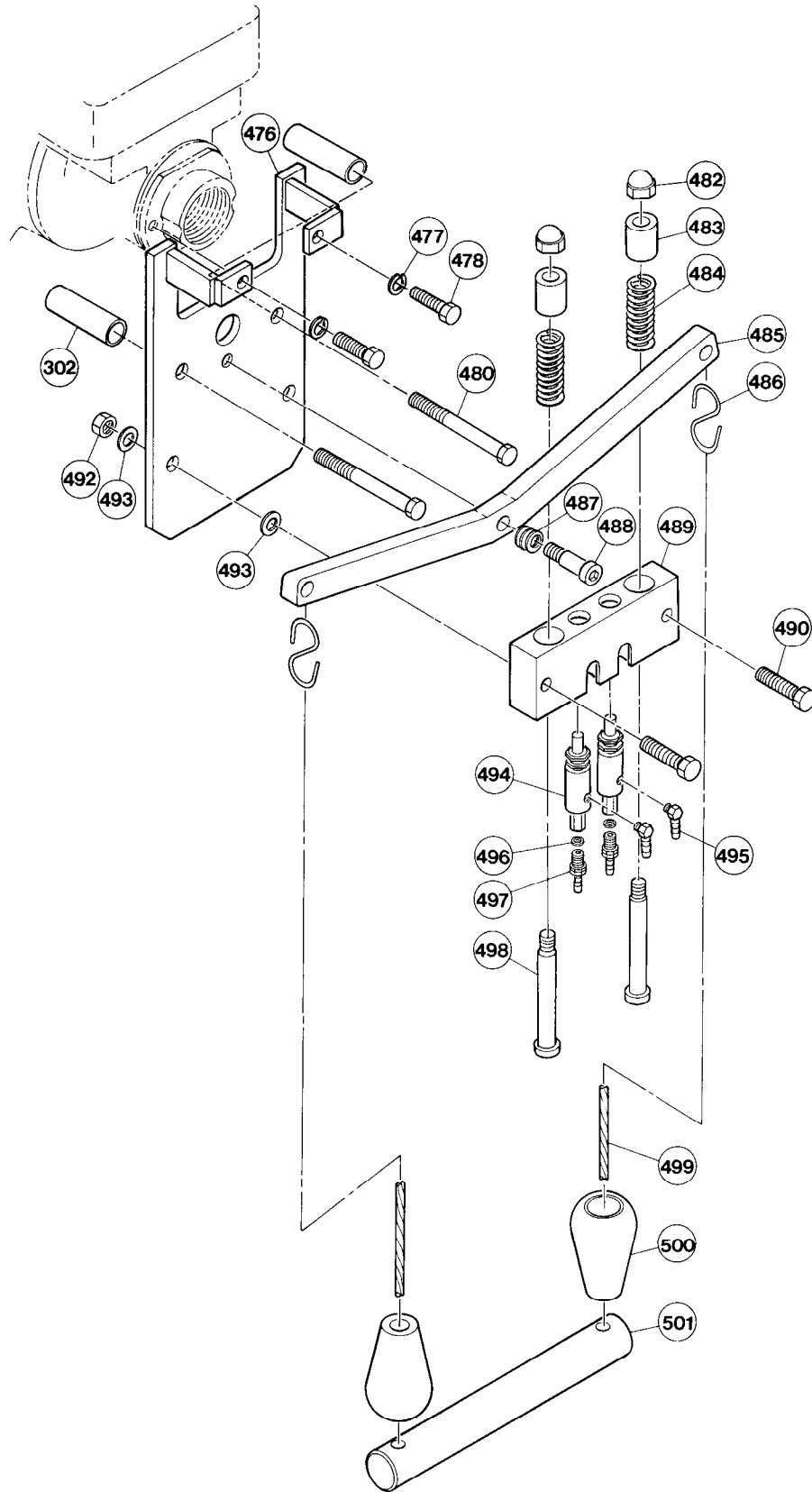

(Dwg. MHTPA0505)

## ROPE CONTROL PARTS LIST

ITEM NO.	DESCRIPTION OF PART	QTY TOTAL	PART NO.
302	Spacer	2	23435-221
476	Bracket	1	20144
477	Lockwasher	2	53836
478	Capscrew	2	71065890
480	Capscrew	2	71087431
482	Nut	2	71055180
483	Spring Guide	2	19729
• 484	<b>Spring</b>	2	<b>50807</b>
485	Lever Arm	1	19414
486	'S' Hook	2	71073316
487	Washer	3	71055206
488	Capscrew	1	71055198
489	Bracket	1	19412
490	Capscrew	2	52844
492	Nut	2	52917
493	Washer	4	54843
• 494	<b>Regulator</b>	2	<b>53018</b>
495	Fitting	2	71044945
• 496	<b>Gasket</b>	2	<b>71044960</b>
497	Fitting	2	71044937
498	Capscrew	2	50848
499	Nylon Rope	2 (Specify Length)	51777
500	Knob	2	4868
501	Handle	1	8273
---	Pressure Control Assembly (Incl's items 482 through 484, 489, 493, 495, 496 and 497)	As Req'd	19417

• Recommended spare



# TRAILING TROLLEY PARTS DRAWING

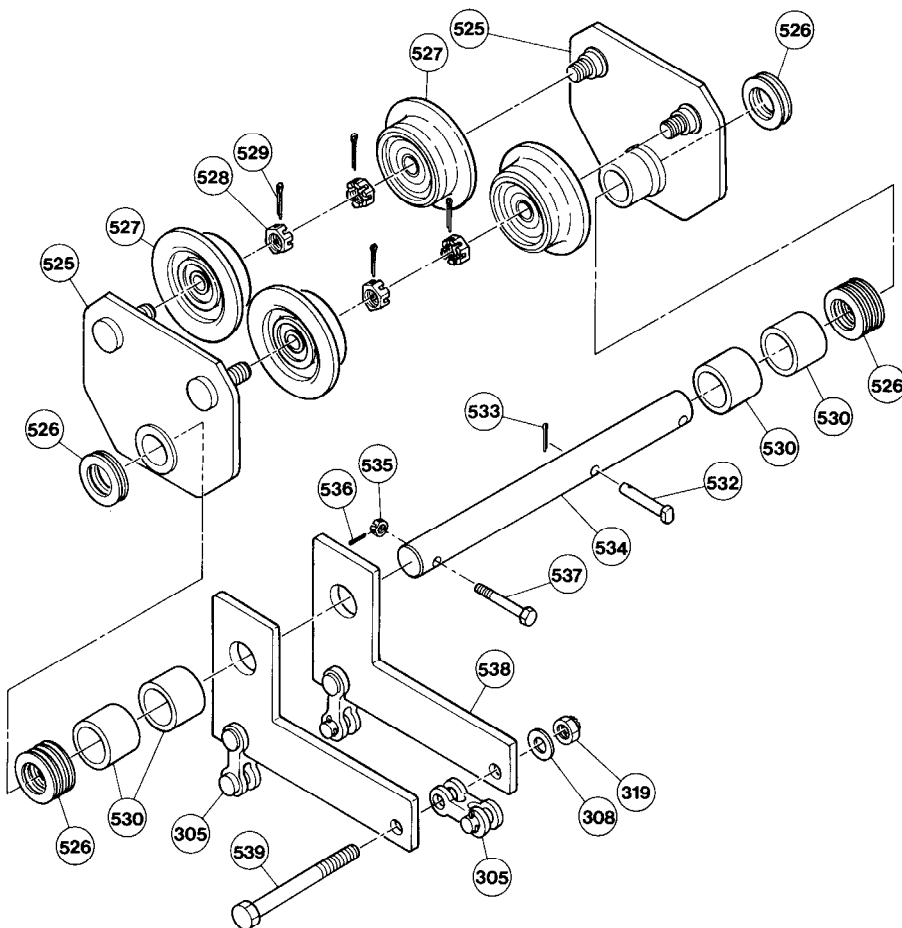

(Dwg. MHTPC0531)

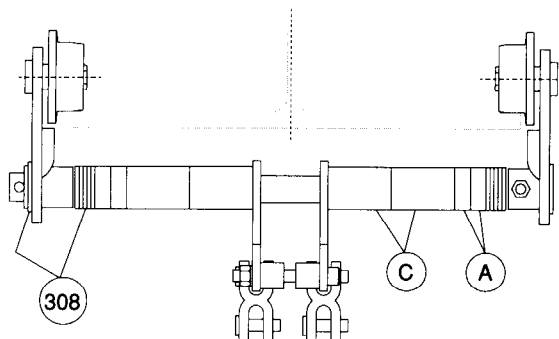

12 to 14-1/2 in. Beam Flange Width

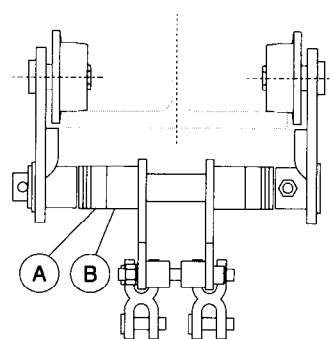

5 to 7 in. Beam Flange Width

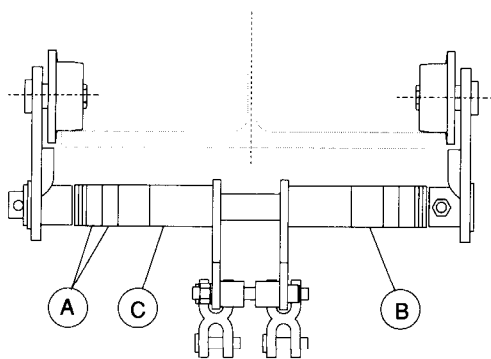

9-1/2 to 12 in. Beam Flange Width

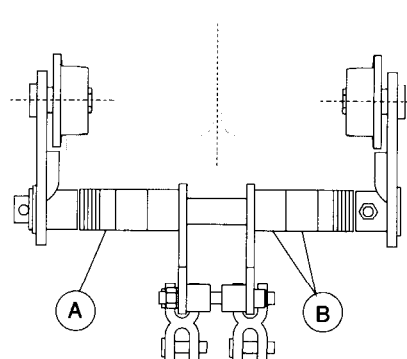

7 to 9-1/2 in. Beam Flange Width

(Dwg. MHTPA0524)

## TRAILING TROLLEY PARTS LIST

ITEM NO.	DESCRIPTION OF PART	QTY REQ'D	PART NUMBER
305	Clevis	3	54645
308	Washer	See Chart	51833
319	Nut	1	71061584
525	Side Plate	2	70812
526	Spacer	24	70842
527	Wheel (Steel) Std.	4	70817
	Wheel (Bronze)		9482
	Wheel (Copper Plate)		70817-CP
528	Nut	4	70826
529	Pin	4	70831
530	Spacer (1/2 in long)	See Chart	23432-050
	Spacer (1 in long)		23432-100
	Spacer (2 in long)		23432-200
532	Stopper Pin	1	70865
533	Pin	1	70853
534	Suspension Shaft (5 to 7 in. beam width)	1	20431-1
	Suspension Shaft (7 to 9-1/2 in. beam width)		20431-2
	Suspension Shaft (9-1/2 to 12 in. beam width)		20431-3
	Suspension Shaft (12 to 14-1/2 in. beam width)		20431-4
535	Nut	1	73316
536	Pin	1	70847
537	Capscrew	1	70855
538	Bracket	2	17895
539	Capscrew	1	54751

### Spacer Chart

Beam Flange Width	Quantity of Spacers Required			
	Item 308	Item 530		
	1/8 in. Thick	1/2 in. Long (A)	1 in. Long (B)	2 in. Long (C)
5 to 7 in.	12	2	2	0
7 to 9-1/2 in.		2	4	0
9-1/2 to 12 in.		4	2	2
12 to 14-1/2 in.	1	4	0	4

Spacer positions shown in dwg. MHTPA0524 are for maximum beam flange widths only. For smaller beam flange width settings, remove spacers (308) as required and place on outside of sideplate.

# HULL BUMPER ASSEMBLY DRAWING AND PARTS LIST

## 20 ton Hoists

## 5, 10 and 15 ton Hoists

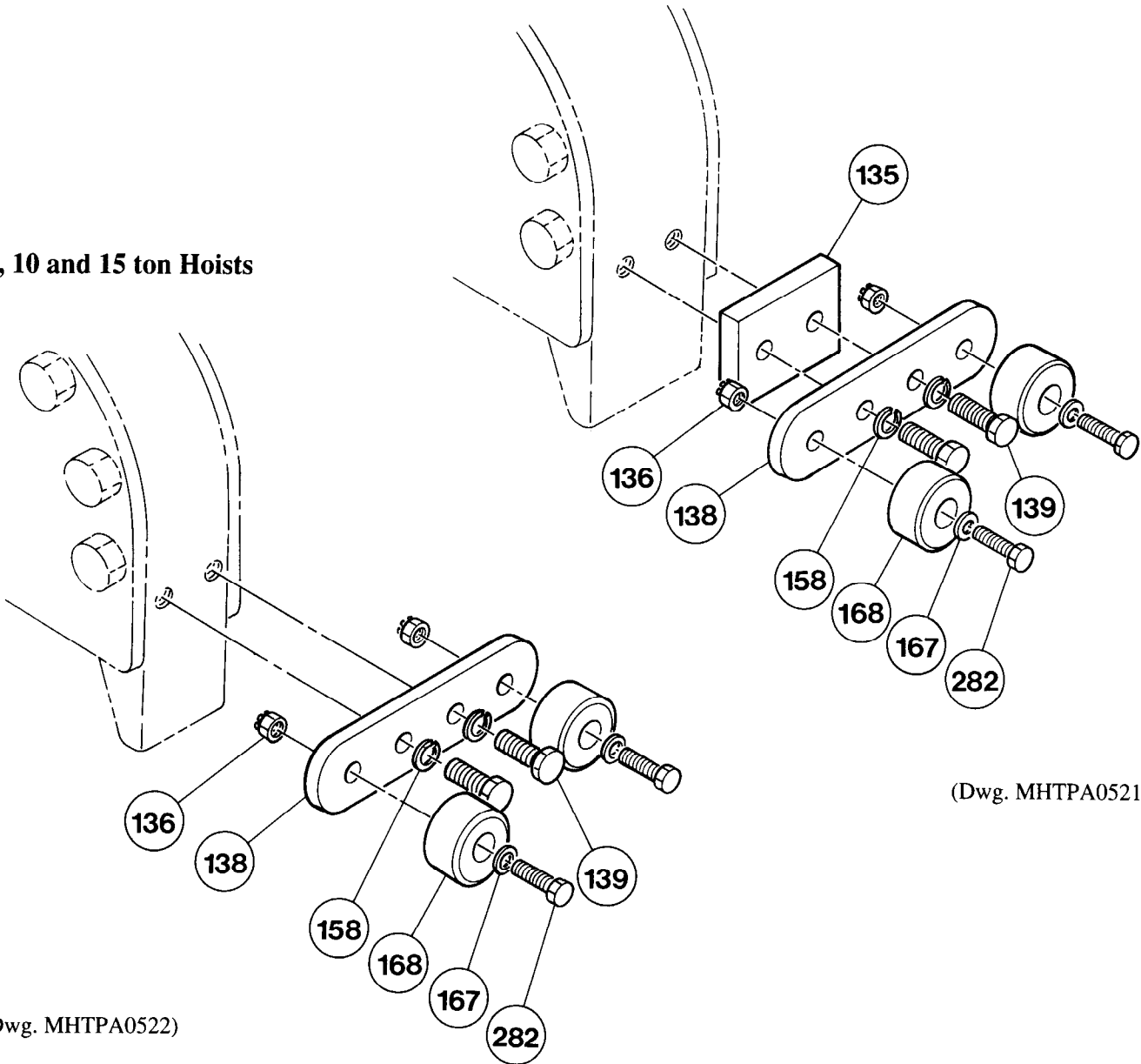

(Dwg. MHTPA0521)

(Dwg. MHTPA0522)

ITEM NO.	DESCRIPTION OF PART	QTY TOTAL	PART NO.	
			5, 10 and 15 ton	20 ton
120	Bumper Assembly	1	18174	19130-1
135	Spacer	2	---	14802
136	Nut	2	71026926	51750
138	Bracket	1	9596-1	
139	Capscrew	2	71110175	50892
158	Lockwasher	2	71027734	---
167	Washer	2	71110183	50182
168	Bumper	2	71756	
282	Capscrew	2	50921	50197

## MUFFLER ASSEMBLY DRAWING AND PARTS LIST

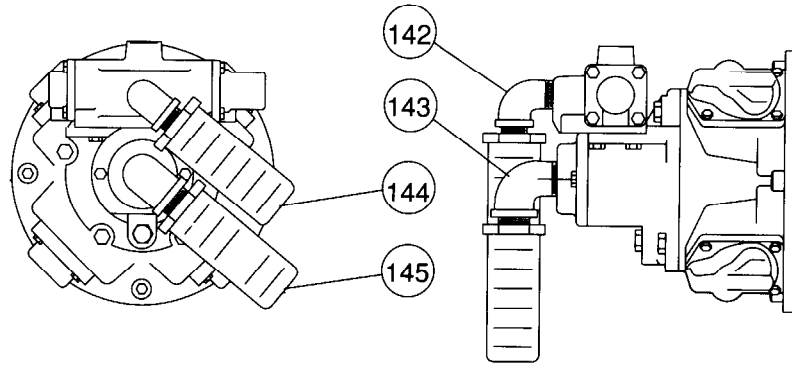

(Dwg. MHTPA0540)

ITEM NO.	DESCRIPTION OF PART	QTY TOTAL	PART NO.	
			HOIST MOTOR	TROLLEY MOTOR
142	Fitting, Elbow	1	52190	71108781
143	Fitting, Elbow	1	53368	52190
144	Muffler	1	52104	
145	Muffler	1	50592	52104

## ACCESSORIES AND REPAIR KITS

DESCRIPTION OF PART	QTY TOTAL	PART NO.
Hoist or Trolley Control Valve Seal Kit (Incl's items 626 and 633)	2	9750-13
Pendant Rebuild Kit (See Dwg. MHTPA0396) (Incl's items 423, 424, 427, 428, 429, 432, 440 and 444)	1	9750-4
Pendant Line Exhaust Valves (Incl's items 192, 193 and 195)	As Req'd	20417
Brake Rebuild Kit	1	HA1-BRK
Brake Exhaust Valve Kit (for hoists with emergency stop only)	1	9750-10
Trolley Gearbox Seal Kit	1	HA1-TGSK
Trolley Drive Vane Motor Kit (Incl's items 251, 252, 254, 258, 262, 264 and 265)	1	1000P60-VMK
Label Kit Hook Mount Hoist	1	18915
Label Kit Trolley Mount Hoist	1	18914
Touch-Up Paint (Orange)	As Req'd	MHD-OR
Chain Lubricant (Food Grade)	As Req'd	LUBRI-LINK GREEN
Chain Lubricant	As Req'd	LUBRI-LINK

# 60 PSI REDUCTION ASSEMBLY DRAWING AND PARTS LIST

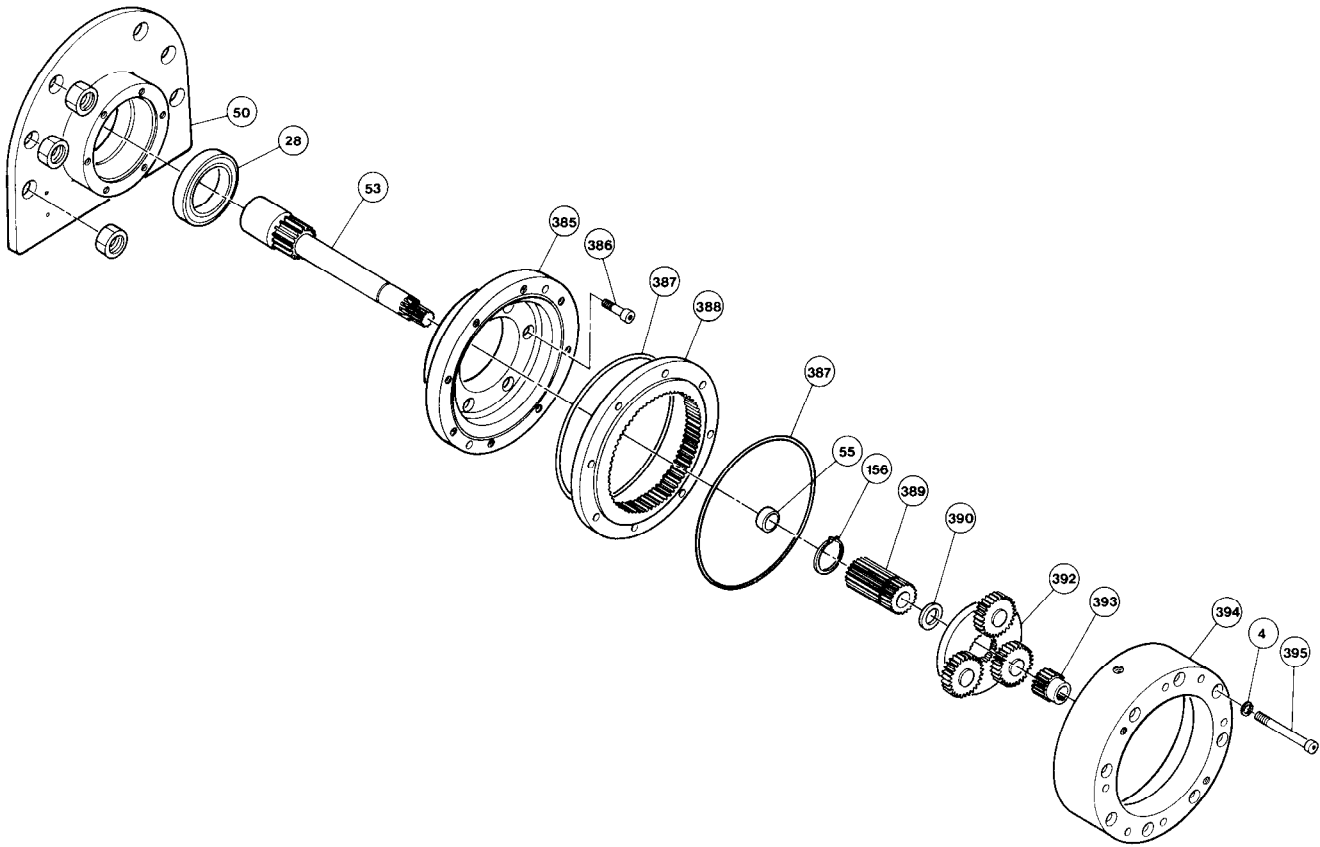

(Dwg. MHTPB0553)

ITEM NO.	DESCRIPTION OF PART	QTY TOTAL	PART NO.
4	Lockwasher	8	50200
156	Retainer Ring	1	51761
385	Adapter	1	18910
386	Capscrew	6	54776
• 387	'O' Ring	2	52149
388	Ring Gear	1	54771
389	Coupling	1	18909
390	Thrust Washer	1	71044291
392	Planet Gear Assembly (5.8:1 ratio)	1	54700
393	Pinion	1	18908
394	Adapter	1	17317
395	Capscrew	8	54777

• Recommended Spare

## LABEL AND TAG PARTS LIST

ITEM NO.	LABEL/TAG DESCRIPTION OR WORDING	WHERE SHOWN	QTY TOTAL		PART NO.
			HOOK MOUNT	TROLLEY MOUNT	
1	Label Kit Hook Mount Hoist	Not Shown	As Req'd	---	18915
2	Label Kit Trolley Mount Hoist	Not Shown	---	As Req'd	18914
3	Tag, Supply Line Notice	See "Warning Labels And Tags" Page 5		1	71042121
4	Label, Hercu-Link Logo	Not Shown	2	3	71046387
5	Tag, Oil Fill Notice	See "Warning Labels And Tags" Page 5		1	71042147
6	Nameplate	See "Parts Ordering Information" Page 78		1	71070098
7	Label, "DRAIN"	Not Shown		1	71043632
8	Label, "AIR SUPPLY"	Not Shown		1	71046395
9	Tag, Oil Level Caution	See "Warning Labels And Tags" Page 5		1	71107148
10	Label, "OIL LEVEL"	Not Shown	3	4	71043616
11	Label, "OIL FILL"	Not Shown	3	4	71042204
12	Label, "EXHAUST"	Not Shown	2	4	71042196
13	Label, "OIL DRAIN"	Not Shown	3	4	71042188
14	Label, "LUBE"	Not Shown	4	8	71042170
15	Label, Ingersoll-Rand Name And Logo	Not Shown	2	0	71106231
16	Label, Ingersoll-Rand Name And Logo	Not Shown	0	3	71106256
17	Tag, Operating Warning	See "Warning Labels And Tags" Page 5		1	71059612
18	Tag, Vent Plug Notice	See "Warning Labels And Tags" Page 5	3	4	71107155
19	Label, Operating Warning	See "Warning Labels And Tags" Page 5	1	2	71107130

**Note:** When ordering label kit or nameplate, hoist model and serial number must be supplied.

### Label and Tag Locations

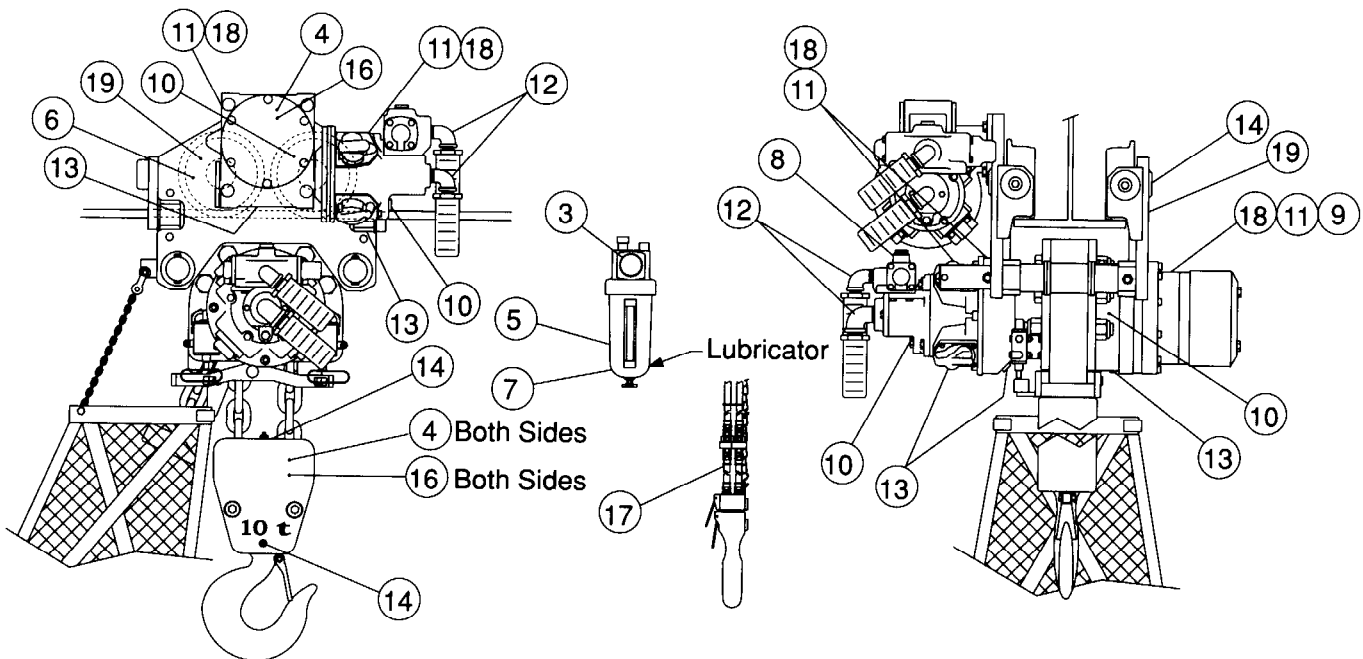

(Dwg. MHTPA0545)

## PARTS ORDERING INFORMATION

The use of replacement parts other than **Ingersoll-Rand** Material Handling may invalidate the Company's warranty. For prompt service and genuine **Ingersoll-Rand** Material Handling parts, provide your nearest Distributor with the following:

1. Complete hoist model number and serial number as it appears on the nameplate.
2. Part number and part description as shown in this manual.
3. Quantity required.

On hook mounted hoists the model and serial number plate is located on the top frame.

On trolley mounted hoists the model and serial number plate is located on the trolley side plate.

<b>INGERSOLL-RAND®</b>		<b>AIR HOIST</b>	
<b>MATERIAL HANDLING</b>			
MODEL No.	_____		
SERIAL No.	_____	No. CHAIN FALLS	_____
MAXIMUM PRESSURE	_____ psig	MAX LIFT CAPACITY	_____ lbs.
MAX LIFT SPEED	_____ ft min	AIR FLOW	_____ cu.ft min
71070038			

For your convenience and future reference it is recommended that the following information be recorded.

**Hoist Model Number**.....

**Hoist Serial Number**.....

**Date Purchased**.....

### Return Goods Policy

**Ingersoll-Rand** will not accept any returned goods for warranty or service work unless prior arrangements have been made and written authorization has been provided from the location where the goods were purchased. Hoists returned with opened, bent or twisted hooks, or without chain and hooks, will not be repaired or replaced under warranty.

### NOTICE

- **Using other than genuine Ingersoll-Rand Material Handling parts may void the warranty.**
- **Continuing improvement and advancement of design may cause changes to this hoist which are not included in this manual. Manuals are periodically revised to incorporate changes. Always check the manual edition number on the front cover for the latest issue.**

When the life of the hoist has expired, it is recommended that the hoist be disassembled, degreased and parts separated as to materials so that they may be recycled. For additional information contact:

**Ingersoll-Rand Material Handling**  
 2724 Sixth Avenue South  
 Seattle, Wa 98124 USA  
 Phone: (206) 624-0466  
 Fax: (206) 624-6265  
 or

**Ingersoll-Rand Material Handling**  
**Samiia, Douai Operations**  
 111, avenue Roger Salengro  
 59450 Sin Le Noble, France  
 Phone: (33) 27-93-08-08  
 Fax: (33) 27-93-08-00

### NOTICE

- **Mineral based oils are recyclable, however, some oils such as glycols may be extremely toxic and must be identified and disposed of at an approved waste or disposal site in accordance with all local, state and federal laws and regulations.**

## HOIST AND WINCH LIMITED WARRANTY

Ingersoll-Rand Company (I-R) warrants to the original user its Hoists and Winches (Products) to be free of defects in material and workmanship for a period of one year from the date of purchase. I-R will repair, without cost, any Product found to be defective, including parts and labor charges, or at its option, will replace such Products or refund the purchase price less a reasonable allowance for depreciation, in exchange for the Product. Repairs or replacements are warranted for the remainder of the original warranty period.

If any Product proves defective within its original one year warranty period, it should be returned to any Authorized Hoist and Winch Service Distributor, transportation prepaid with proof of purchase or warranty card.

This warranty does not apply to Products which I-R has determined to have been misused or abused, improperly maintained by the user, or where the malfunction or defect can be attributed to the use of non-genuine I-R parts.

**I-R makes no other warranty, and all implied warranties including any warranty of merchantability or fitness for a particular purpose are limited to the duration of the expressed warranty period as set forth above.**

**I-R's maximum liability is limited to the purchase price of the Product and in no event shall I-R be liable for any consequential, indirect, incidental, or special damages of any nature arising from the sale or use of the Product, whether based on contract, tort, or otherwise.**

**Note:** Some states do not allow limitations on incidental or consequential damages or how long an implied warranty lasts so that the above limitations may not apply to you.

This warranty gives you specific legal rights and you may also have other rights which may vary from state to state.

## IMPORTANT NOTICE

It is our policy to promote safe delivery of all orders.

This shipment has been thoroughly checked, packed and inspected before leaving our plant and receipt for it in good condition has been received from the carrier. Any loss or damage which occurs to this shipment while enroute is not due to any action or conduct of the manufacturer.

### **VISIBLE LOSS OR DAMAGE**

If any of the goods called for on the bill of lading or express receipt are damaged or the quantity is short, do not accept them until the freight or express agent makes an appropriate notation on your freight bill or express receipt.

### **CONCEALED LOSS OR DAMAGE**

When a shipment has been delivered to you in apparent good condition, but upon opening the

crate or container, loss or damage has taken place while in transit, notify the carrier's agent immediately.

### **DAMAGE CLAIMS**

You must file claims for damage with the carrier. It is the transportation company's responsibility to reimburse you for repair or replacement of goods damaged in shipment. Claims for loss or damage in shipment must not be deducted from the Ingersoll-Rand invoice, nor should payment of Ingersoll-Rand invoice be withheld awaiting adjustment of such claims as the carrier guarantees safe delivery.

You may return products damaged in shipment to us for repair, which services will be for your account and form your basis for claim against the carrier.



## United States Office Locations

### For Order Entry and Order Status:

#### Ingersoll-Rand Distribution Center

510 Hester Drive  
P.O. Box 618  
White House, TN 37188  
Phone: (615) 672-0321  
Telex: 786573  
Fax: (615) 672-0801

### For Technical Support:

#### Ingersoll-Rand Material Handling

2724 Sixth Avenue South  
P.O. Box 24046  
Seattle, WA 98124-0046  
Phone: (206) 624-0466  
Telex: 328795  
Fax: (206) 624-6265

### Regional Sales Offices

#### Atlanta, GA

111 Ingersoll-Rand Drive  
Chamblee, GA 30341  
Phone: (404) 936-6230

#### Detroit, MI

23192 Commerce Drive  
Farmington Hills, MI 48335  
Phone: (313) 476-6677  
Fax: (313) 476-6670

#### Houston, TX

2500 East T.C. Jester  
Suite 150  
Houston, TX 77008  
Phone: (713) 864-3700

#### Los Angeles, CA

5533 East Olympic Blvd.  
Los Angeles, CA 90022  
Phone: (213) 725-2826

#### Milwaukee, WI

12311 W. Silver Spring Dr.  
Milwaukee, WI 53225  
Phone: (414) 461-0973

#### Philadelphia, PA

900 E. 8th Ave., Suite 103  
P.O. Box 425  
King of Prussia, PA 19406  
Phone: (215) 337-5930

## International

Offices and distributors in principal cities throughout the world. Contact the nearest **Ingersoll-Rand** office for the name and address of the distributor in your country or write/fax to:

#### Ingersoll-Rand Material Handling

P.O. Box 24046 Seattle,  
WA 98124-0046 USA  
Phone: (206) 624-0466  
Telex: 328795  
Fax: (206) 624-6265

### Canada

#### National Sales Office Regional Warehouse

**Toronto, Ontario**  
51 Worcester Road  
Rexdale, Ontario  
M9W 4K2  
Phone: (416) 675-5611  
Fax: (416) 675-6920  
Order Desk  
Fax: (416) 674-6549

### Regional Sales Offices

#### Calgary, Alberta

44 Harley Road S.E.  
Calgary, Alberta  
T2V 3K3  
Phone: (403) 252-4180  
Fax: (403) 252-4462

#### Edmonton, Alberta

1430 Weber Center  
5555 Calgary Trail N.W.  
Edmonton, Alberta  
T6H 5G8  
Phone: (403) 438-5039  
Fax: (403) 437-3145

#### Montreal, Quebec

3501 St. Charles Blvd.  
Kirkland, Quebec  
H9H 4S3  
Phone: (514) 695-9040  
Fax: (514) 695-0963

### British Columbia

201-6351 Westminster Hwy  
Richmond, B.C.  
V7C 5C7  
Phone: (604) 278-0459  
Fax: (604) 278-2519

### Latin America Operations Ingersoll-Rand Production Equipment Group

730 N.W. 107 Avenue  
Suite 300, Miami, FL  
33172-3107  
Phone: (305) 559-0500  
Telex: 441617TLS UI  
Fax: (305) 559-7505

### Europe, Middle East and Africa

#### Ingersoll-Rand

#### Material Handling

#### Samiia, Douai Operations

111, avenue Roger Salengro  
59450 Sin Le Noble, France  
Phone: (33) 27-93-08-08  
Fax: (33) 27-93-08-00

### Asia - Pacific

#### Ingersoll-Rand (Japan) Ltd.

Kowa Bldg. No. 17  
2-7 Nishi-Azabu 1-chome  
Minato-ku, Tokyo 106, Japan  
Phone: (03) 3403-0641/7  
Fax: 81 3 3401-2049

### Russia

#### Ingersoll-Rand Company

World Trade Center  
Office 1101  
Krasnopresnenskaya Nab. 12  
Moscow, Russia 123610