

IMPORTANT INFORMATION:

- A copy of our “Safe Operating Practices” Manuals are always available free of charge either by downloading it from our Technical Publications website @ www.airwinch.com or by contacting the Factory at (800) 866-5457 for North America and (206) 624-0466 for International. The Safe Operating Practices manual must be read prior to anyone operating a **Ingersoll-Rand** winch or hoist. The manual form numbers are as follows:

“Safe Operating Practices Non-Man Rider™ Winches” Manual, Form No. MHD56250

“Safe Operating Practices for Man Rider™ Winches” Manual, Form No. MHD56251

“Safe Operating Practices for Pneumatic, Hydraulic and Electric Hoists” Manual, Form No. MHD56295

- Available winch options may require additional supplements to the basic winch manual.
- For Man Rider™ winches ensure a copy of the Man Rider™ supplement is made available to the operator prior to winch operation.

Winch Man Rider™ Supplements:

Model:	Publication No.
FA2, FA2.5, FH2, FH2.5	MHD56046
FA5	MHD56042 and MHD56220
FA10	MHD56252
FA2.5A	MHD56236
FA2B and HU40A	MHD56207
FH10MR	MHD56212
Fulcrum Electric	MHD56277
LS500HLP/ LS1000HLP	SAM0004

Model:	Publication No.
LS500RLP	SAM0011
LS1000RLP	SAM0012
LS150RLP	SAM0082
LS150RLP/500/ 1000	SAM0115
LS150RLP and LS150PLP-PH	SAM0120
LS500RLP-E	SAM0122
LS150RLP- DP5M-F	SAM0184
LS150HLP	SAM0222

- We strongly recommend that ALL maintenance on **Ingersoll-Rand** equipment be carried out by personnel certified by **Ingersoll-Rand**, or by **Ingersoll-Rand** Authorized Service Centers.
- Contact the Factory if in doubt about installation, operation, inspection and maintenance instructions.
- Use only Genuine **Ingersoll-Rand** parts when maintaining or repairing a winch, hoist or any component of a winch or hoist.
- ANSI / ASME recommends that a winch or hoist (or any components of a winch or hoist) that has been repaired be tested prior to being placed into service:
 - * **Winches** - ANSI / ASME B30.7 (BASE MOUNTED DRUM HOISTS) Refer to section 7.2.2 - Testing.
 - * **Hoists** - ANSI / ASME B30.16 (OVERHEAD HOISTS - UNDERHUNG) Refer to section 16.2.2 - Testing.

PARTS, INSTALLATION AND MAINTENANCE MANUAL
for
***Hercu-Link*TM AIR HOISTS**
MODELS

HA2-012
(12.5 metric tons)

HA2-037
(37.5 metric tons)

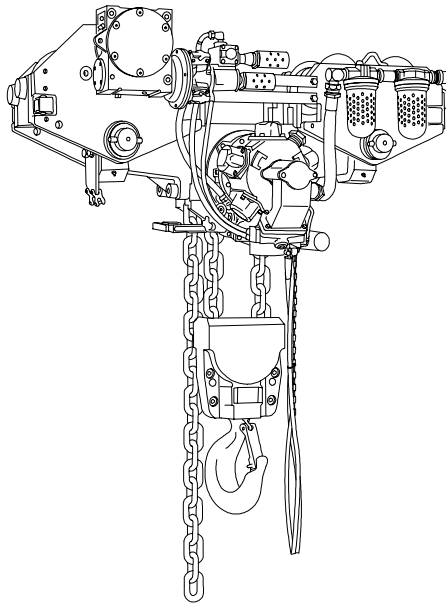

HA2-025
(25 metric tons)

HA2-050
(50 metric tons)

(Dwg. MHP2246)

Tons in this manual are metric tons (1 metric ton = 2,200 lbs.)

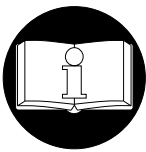

READ THIS MANUAL BEFORE USING THESE PRODUCTS. This manual contains important safety, installation, and maintenance information. Make this manual available to all persons responsible for the installation, operation, and maintenance of these products.

⚠ WARNING

Do not use this hoist for lifting, supporting, or transporting people or lifting or supporting loads over people.

Always operate, inspect and maintain this hoist in accordance with applicable safety codes and regulations.

TABLE OF CONTENTS

Description	Page No.	
Safety Information		
Danger, Warning, Caution and Notice	3	
Safe Operating Instructions	4	
Warning Labels And Tags	5	
Specifications		
Model Code Explanation	6	
General Specifications	7	
Installation		
Mounting	8	
Installing Trolley	8	
Rack Drive	9	
Chain Container	10	
Air Supply	11	
Pendant (Optional Style)	12	
Storing Hoist	13	
Air Schematics	14	
Operation		
Initial Operating Checks	15	
Hoist Controls	15	
Emergency Stop	16	
Rope Pull	17	
Inspection		
Records and Reports	17	
Frequent Inspection	18	
Periodic Inspection	19	
Hoists Not in Regular Use	19	
Inspection And Maintenance Report	20	
Lubrication		
Pivot Points and Bushings	21	
Hoist Motor	21	
Piston Trolley Drive Motor	21	
Bottom Hook Block Assembly	21	
Load Chain	21	
Trolley Drive Assembly	22	
Reduction Gear Assembly	22	
Seals and Bearings	23	
Troubleshooting		24
Maintenance		
Maintenance Intervals	26	
Disc Brake Adjustment	26	
Load Chain Replacement	26	
General Disassembly	29	
Cleaning, Inspection and Repair	32	
Assembly Instructions	33	
Load Test	38	
Parts Information		
Hoist Drawings & Parts List Table of Index	39	
Parts Ordering Information	82	
Return Goods Policy	82	
Warranty	83	

SAFETY INFORMATION

This manual provides important information for all personnel involved with safe installation, operation and proper maintenance of this product. Even if you feel you are familiar with this or similar equipment, you should read this manual before operating product.

Danger, Warning, Caution and Notice

Throughout this manual there are steps and procedures which, if not followed, may result in an injury. The following signal words are used to identify the level of potential hazard.

DANGER

Danger is used to indicate the presence of a hazard which *will* cause *severe* injury, death, or substantial property damage if the warning is ignored.

WARNING

Warning is used to indicate the presence of a hazard which *can* cause *severe* injury, death, or substantial property damage if the warning is ignored.

CAUTION

Caution is used to indicate the presence of a hazard which *will* or *can* cause injury or property damage if the warning is ignored.

NOTICE

Notice is used to notify people of installation, operation, or maintenance information which is important but not hazard-related.

Safety Summary

WARNING

- Do not use this hoist or attached equipment for lifting, supporting or transporting people or lifting or supporting loads over people.
- Air powered hoists are designed to provide a 5 to 1 safety factor and are factory tested to 125% of rated load. The supporting structures and load-attaching devices used in conjunction with this hoist must provide adequate support to handle all hoist operations plus weight of hoist and attached equipment. This is the customer's responsibility. If in doubt, consult a registered structural engineer.

NOTICE

- Lifting equipment is subject to different regulations in each country. These regulations may not be specified in this manual.

The National Safety Council, Accident Prevention Manual for Industrial Operations, Eighth Edition, and other recognized safety sources make a common point: Employees who work near suspended loads or assist in hooking on or arranging a load should be instructed to keep out from under load. From a safety standpoint, one factor is paramount: conduct all lifting or pulling operations in such a manner that if there were an equipment failure, no personnel would be injured. This means keep out from under a raised load and keep out of intended path of any load.

Ingersoll-Rand hoists are manufactured in accordance with the latest ASME B30.16 standards.

The Occupational Safety and Health Act of 1970 generally places the burden of compliance with user, not manufacturer. Many OSHA requirements are not concerned or connected with the manufactured product but are, rather, connected with final installation. It is the owner's and user's responsibility to determine the suitability of a product for any particular use. It is recommended that all applicable industry, trade association, federal, state and local regulations be checked. Read all operating instructions and warnings before operation.

Rigging: It is the responsibility of the operator to exercise caution, use common sense and be familiar with proper rigging techniques. Refer to ASME B30.9 for rigging information, American National Standards Institute, 1430 Broadway, New York, NY 10018.

This manual has been produced by **Ingersoll-Rand** to provide dealers, mechanics, operators and company personnel with the information required to install, operate, maintain and repair the products described herein.

It is extremely important that mechanics and operators be familiar with the servicing procedures of these products, or like or similar products, and are physically capable of conducting the procedures. These personnel shall have a general working knowledge that includes:

1. Proper and safe use and application of mechanics common hand tools as well as special **Ingersoll-Rand** or recommended tools.
2. Safety procedures, precautions and work habits established by accepted industry standards.

Ingersoll-Rand cannot know of, or provide all procedures by which product operations or repairs may be conducted and hazards and/or results of each method. If operation or maintenance procedures not specifically recommended by manufacturer are conducted, it must be ensured that product safety is not endangered by actions taken. If unsure of an operation or maintenance procedure or step, personnel should place the product in a safe condition and contact supervisors and/or factory for technical assistance.

SAFE OPERATING INSTRUCTIONS

The following warnings and operating instructions have been adapted in part from American National (Safety) Standard ASME B30.16 and are intended to avoid unsafe operating practices which might lead to injury or property damage.

Ingersoll-Rand recognizes that most companies who use hoists have a safety program in force at their facility. In the event that some conflict exists between a rule set forth in this publication and a similar rule already set by an individual company, the more stringent of the two should take precedence.

Safe Operating Instructions are provided to make an operator aware of dangerous practices to avoid and are not necessarily limited to the following list. Refer to specific sections in the manual for additional safety information.

1. Only allow personnel trained in safety and operation of this product to operate and maintain unit.
2. Only operate a hoist if you are physically fit to do so.
3. When a “**DO NOT OPERATE**” sign is placed on hoist, or controls, do not operate hoist until sign has been removed by designated personnel.
4. Before each shift, check both hoist and trolley for wear and damage. Never use a unit that inspection indicates is worn or damaged.
5. Never lift a load greater than rated capacity of hoist. Refer to “SPECIFICATIONS” section on page 7.
6. Keep hands, clothing, etc., clear of moving parts.
7. Never place your hand in throat area of a hook.
8. Always rig loads properly and carefully.
9. Never use load chain as a sling.
10. Be certain load is properly seated in saddle of hook. Do not tipload hook as this leads to spreading and eventual failure of hook.
11. Do not “side pull” or “yard”.
12. Make sure everyone is clear of load path and there are no objects in way of load. Do not lift a load over people.
13. Never use hoist for lifting or lowering people, and never allow anyone to stand on a suspended load.
14. Ease slack out of chain when starting a lift. Do not jerk load.
15. Do not swing a suspended load.
16. Never suspend a load for an extended period of time.
17. Never leave a suspended load unattended.
18. Pay attention to load at all times when operating hoist.
19. After use, properly secure hoist and all loads.
20. The operator must maintain an unobstructed view of load at all times.
21. Never operate a hoist with twisted, kinked or damaged chain.
22. After use, or when in a non-operational mode, unit should be secured against unauthorized and unwarranted use.
23. Do not do anything you believe may be unsafe.
24. Never splice a load chain by inserting a bolt between links or by any other means.
25. Do not force a chain or hook into place by hammering. Do not insert point of hook into a chain link.
26. Do not expose load chain to freezing temperatures, and do not apply sudden loads to a cold chain.
27. Follow lubrication instructions.
28. Do not attempt to repair load chains or hooks. Replace them when they become worn or damaged.
29. Periodically inspect hoist thoroughly and replace worn or damaged parts.
30. Shut off air supply before performing maintenance on hoist or trolley.
31. Do not use load chain as a ground (earth) for welding. Do not attach a welding electrode to a hoist or chain.
32. Avoid collision or bumping of trolley.

WARNING LABELS AND TAGS

Each hoist is supplied from factory with warning labels and tags shown. If labels or tags are not attached to your hoist, order new labels or tags and install them. Refer to Label and Tag parts list in "PARTS" section on page 80. Read and obey all warnings and other safety information attached to this hoist. Labels or tags may not be shown actual size.

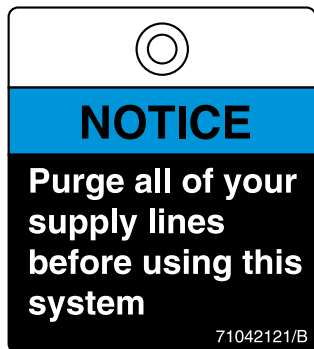

Tag part number 71042121 is attached to inlet air supply components.

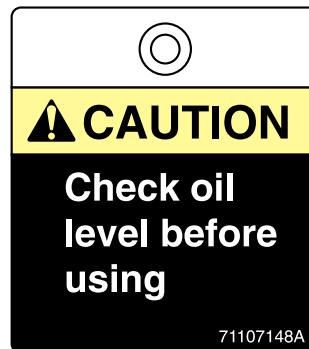

Tag part number 71107148 is attached to power head reduction gear assembly.



Tag part number 71042147 is attached to lubricator in inlet air supply line.



Label part number 71107130 is attached to trolley side plate.

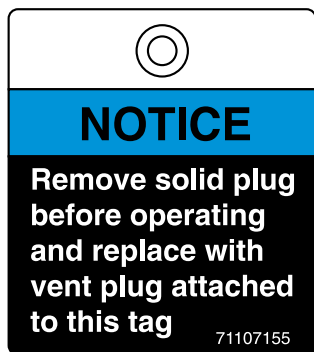

Tag part number 71107155 is attached to power head reduction gear assembly fill plug.

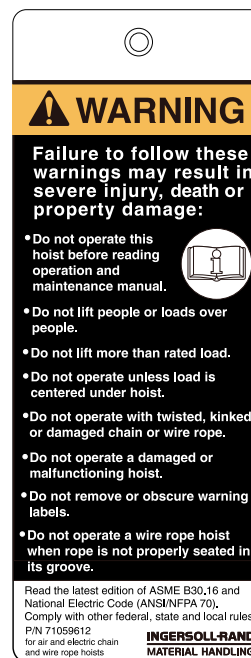

Tag part number 71059612 is attached to pendant assembly.

MODEL CODE EXPLANATION

Example: HA2-025MA3-10-6PA

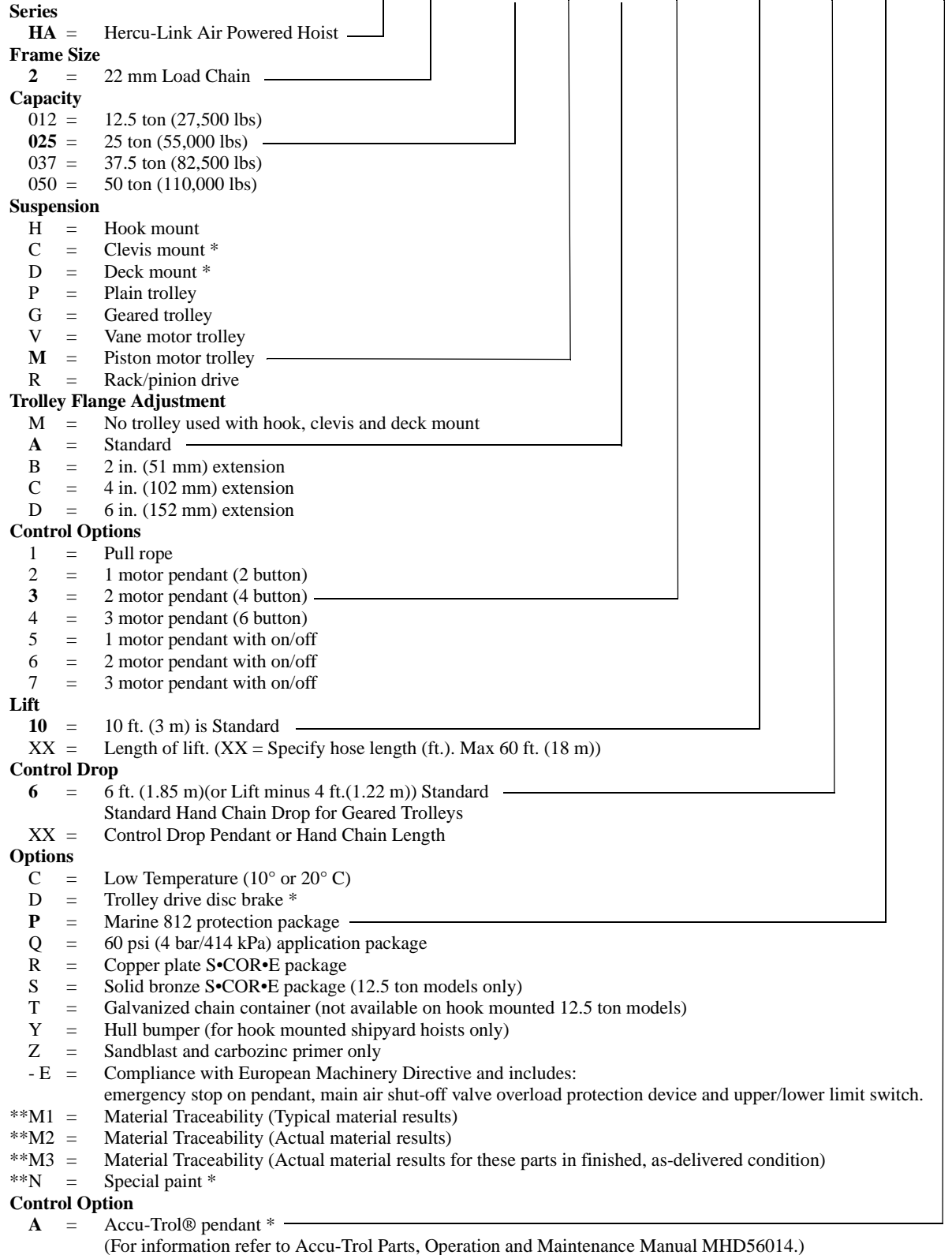

* Features not covered in this manual. For additional information contact your nearest **Ingersoll-Rand** Office or distributor.

** Documentation, witness testing and material traceability available; must be requested at time of order. Specify options or contact the factory or your nearest **Ingersoll-Rand** distributor for information.

GENERAL SPECIFICATIONS

Description

The **HA2** air-powered hoist consists primarily of a power head assembly that acts as control for lower hook block movement. The power head assembly is made up of three main sections: gear reducer section, brake/motor section and sheave section.

Output shaft from piston motor is connected to brake shaft. The brake shaft is connected to drive shaft by way of a coupling that passes through center of brake and sheave section and acts as sun gear for first stage planetary reducer. The gear reducer section consists of three planetary assemblies with each planetary assembly being driven by sun gear from previous planetary assembly. Output from planetary reduction section is transmitted directly to load chain sheave(s).

Motor-driven brake shaft is connected to brake through a sprag clutch. In hoist “UP” direction, clutch allows shaft to rotate without releasing brake. No air pressure is applied to brake piston in “UP” direction.

Brake shaft cannot rotate in hoist “DOWN” direction until brake has been released. Brake is released by air pressure applied to annular brake piston and piston compresses brake springs, releasing brake discs. There are four sintered, bronze-type brake friction discs and five stationary brake discs.

Brake piston is actuated by air from main control valve. When control pendant “DOWN” button is pushed, it moves main control valve spool. The spool is designed to send air to brake in “DOWN” direction only. When pendant “DOWN” button is released, exhaust valves allow brake to set quickly and avoid downward load drift.

Table 1 — Specifications

Hoist Model		HA2-012	HA2-025	HA2-037	HA2-050	
Capacity	metric tons	12.5	25	37.5	50	
Load Chain Size	mm	22				
Chain Falls		1	2	3	4	
Standard Lift	ft	10				
	m	3				
Speed at 105 psi (700kPa/7 bar)	Lift	fpm	8	4	2.5	2
		m/min	2.4	1.2	0.76	0.61
	Lower	fpm	12	6	3.75	3
		m/min	3.7	1.8	1.1	0.9
Horsepower		9.4				
Air Consumption	scfm	280				
	cu. m/min	8				
Speed at 60 psi (400 kPa/4 bar)	Lift	fpm	3.4	1.7	1.1	0.8
		m/min	1.04	0.5	0.3	0.2
	Lower	fpm	4.6	2.3	1.5	1.1
		m/min	1.4	0.7	0.5	0.3
Head Room	Hook Mount	in.	38.5	51.2	66.5	75.1
		mm	978	1299	1689	1907
	Trolley Mount	in.	24.7	41	49	53
		mm	627	1040	1243	1346
Unit Weight	Hook Mount	lbs	965	1235	2230	2955
		kg	439	561	1014	1343
	Trolley Mount (Piston Motor)	lbs	1415	1660	3700	4665
		kg	643	755	1681	2120

Traceability

Load bearing parts are documented to provide traceability. The documentation includes chemical and physical properties of the raw material, heat treating, hardening, tensile and charpy tests as required for the part. Units with M1, M2 or M3 in the model code have traceable load-bearing components.

M1—Material Traceability certificates according to EN 10204 (Ex DIN 50049) 2.2 on load bearing parts. Conformity documents affirm (by the manufacturer) that parts are in compliance with the requirements of the order based on non-specific inspection and testing (i.e. results are typical material properties for these parts).

M2—Material Traceability certificates according to EN 10204 (Ex DIN 50049) 3.1b on load bearing parts. Conformity documents affirm (by a department independent of the manufacturing

department) that the actual parts are in compliance with the requirements of the order based on specific inspection and testing (i.e. results are actual material properties for these parts).

M3–Material Traceability certificates according to EN 10204 (Ex DIN 50049) 3.1b on load bearing parts. Conformity documents affirm (by a department independent of the manufacturing department) that the actual parts used in the product are in

compliance with the order based on specific inspection and testing (i.e. results are actual material properties for these parts in a finished, as delivered condition).

Components with part numbers ending in CH are charpy parts for use under extreme cold conditions. Traceability requirements must be stated when reordering these parts for continued certification.

INSTALLATION

Prior to installing hoist, carefully inspect it for possible shipping damage.

WARNING

• **Before installing hoist read “SAFETY INFORMATION” section on page 3.**

Hoists are supplied from factory with correct grade and quantity of lubricating oil. Before operation all oil levels must be checked and/or topped off with type of oil recommended in “LUBRICATION” section on page 21. Lubricate load chain before operating hoist.

CAUTION

• **Owners and users are advised to examine specific, local or other regulations, including American National Standards Institute and/or OSHA Regulations which may apply to a particular use of this product before installing or putting hoist to use.**

Remove cover from shipping crate. Carefully remove steel straps. On units equipped with a trolley, attach wire rope sling to suspender lugs on trolley side plates and slowly lift into position. Lift hook-mounted hoists into position using hoist top hook.

Attach chain container to hoist with chain container bolt (317). For hook-mounted hoists, hang hook (320) on end of chain from top hook mounting structure. For trolley-mounted hoists, bolt chain to bracket under trolley suspension yoke. For both hoist mountings, refer to Dwg. MHP1524 on page 70.

WARNING

• **A falling load can cause injury or death. Before installing trolley and hoist, read “SAFETY INFORMATION” on page 3**
• **Depending on size of hoist selected it could weigh as much as 4665 lbs (2120 kg). If parts of trolley or hoist are dropped, they could cause injury or damage property. Adequately support hoist and trolley when lifting them into place on beam.**

Hook Mounted Hoist

Place top hook (408) over mounting structure. Make sure hook latch is engaged.

Installing Trolley Over End of Beam

Preadjust trolley width for beam flange measurement. Refer to ‘Installing from Underneath Beam.’ Remove rail stop and slide trolley on end of beam. Reinstall rail stop. If this procedure cannot be used due to insufficient space or fixed limit stops the trolley must be installed from underneath beam using the procedure which follows.

Installing Trolley from Underneath Beam

Refer to Dwg. MHP0340 on page 9 and to items in Dwg. MHP0352 on page 9.

1. Measure beam flange width ‘Y’ and compare with measurement between trolley wheel flanges ‘X’. The correct total clearance (X-Y) between beam and trolley wheel flanges is 1/16 to 3/16 in. (1.6 to 4.7 mm). Refer to Dwg. MHP0340 on page 9.
2. To adjust trolley wheel spacing remove eight cotter pins (173) and four pins (174) at each side plate (150) or (184). Remove adjusting spacers (156) and side plates and add or subtract an equal number of adjusting spacers (156) between suspension yokes (170) and side plates.
3. When desired trolley wheel spacing measurement is achieved, install remaining adjusting spacers (156) on outside of one pair of side plates. Install suspension yoke pins (174) and cotter pins (173) on ends of suspension yokes (170) bend ends apart to secure. Use lifting lugs on trolley side plates to adequately support hoist and side plates and raise into place on beam flange.

CAUTION

• **To avoid an unbalanced load which may damage trolley, hoist must be centered under trolley using spacers (156).**

4. Using lifting lugs on second pair of trolley side plates raise into place beneath beam flange. Slide side plates onto suspension yokes and push side plates together.
5. Slide extra spacers (156) over free end of suspension yoke (170). Insert suspension yoke pin (174) into hole in suspension yoke (170). Secure by installing cotter pins (173) and bending ends apart.

Beam Clearance and Trolley Spacer Placement

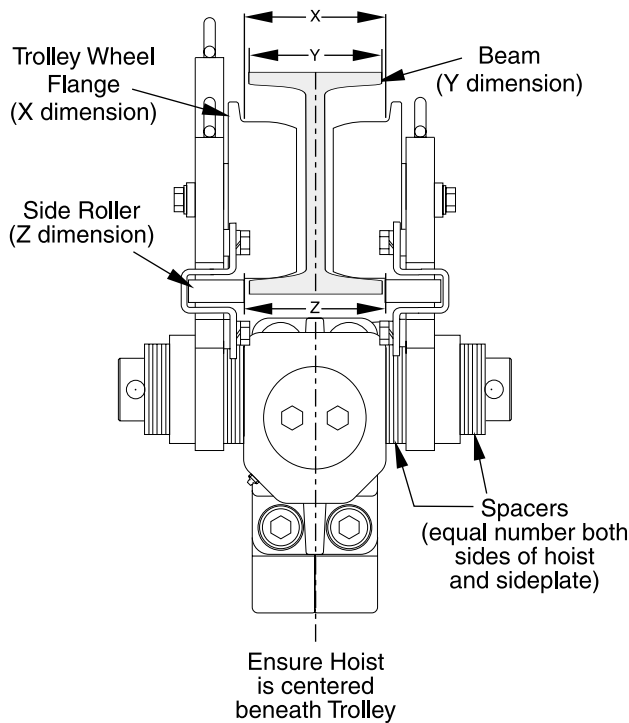

(Dwg. MHP0340)

NOTICE

• Trolley wheels ride on top of lower flange of beam.

- The pin (174) and outside spacers (156) must hold trolley to adjustment in step 1. If side plates can be spread farther apart, install more outside spacers (156) between side plate (150) and pin (174).
- Measure beam flange width 'Y' and compare with measurement between rollers 'Z'. Side roller spacing measurement should be 1/16 to 3/16 in. (1.6 to 4.7 mm) greater than beam flange width.
- Prior to using, test trolley. Check that trolley side plates are vertical. Raise a load equal to rated capacity of hoist 6 to 7 ins. (130 to 180 mm) off floor and operate trolley along entire length of beam.
- Remove connecting plates (159) by removing capscrews (157) and lockwashers (158) after installation is complete. Ensure beam stops are installed.

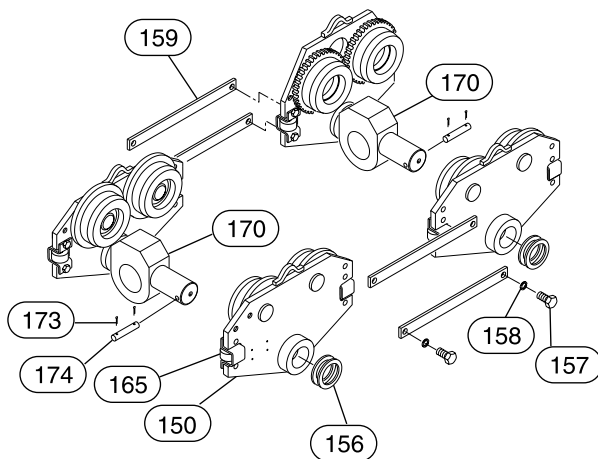

(Dwg. MHP0352)

NOTICE

- Item numbers on Dwg. MHP0352 reference items numbers shown on Dwg. MHP1525 on page 60 and Dwg. MHP0282 on page 62.

Rack Drive (optional feature)

Pre-Installation Checks

Refer to Dwg. MHP1177 on page 9.

Before welding rack segments onto trolley beam, install rack segments on the bottom of the beam lower flange and clamp in place. Mount trolley on the lower beam flange. Measure gap between outside diameter of drive pinion and root of rack segment teeth. Trolley drive pinion and rack teeth must have a 0.06 to 0.10 inch (1.5 to 2.5 mm) clearance.

Adjust clearance:

Refer to Dwg. MHP1605 on page 10.

There is an adjustment screw located below reducer adapter.

- Loosen capscrews attaching trolley drive to sideplate.
- Loosen jam nut and rotate adjustment screw to achieve clearance, refer to Dwg. MHP1177 on page 9.
- Tighten jam nut and mounting screws.

If a larger adjustment is required.

- Add shims between rack segment and beam to decrease distance.
- Remove material from rack segment to increase distance.

Installing Rack Segments Onto Beam

Refer to Dwg. MHP1178 on page 10 and MHP1632 on page 10. Rack segments should be installed on outside edge of lower flange of the trolley beam. Allow 1/4 inch (6.5 mm) clearance between edge of lower flange and rack segment for fillet weld. Rack segments should be clamped tight against lower flange so that there is no sagging. Sagging of the rack could cause drive pinion to bind as it traverses along runway beam.

Racks are provided in segments. These segments should be tack welded (refer to Dwg. MHP1632 on page 10) in place and trolley traversed the entire length. During this movement observe for any high or low spots and correct. Also check each segment connection for drive tooth contact and correct as necessary. When all clearances are achieved, weld both sides of rack to beam flange to prevent corrosion between rack segment and beam.

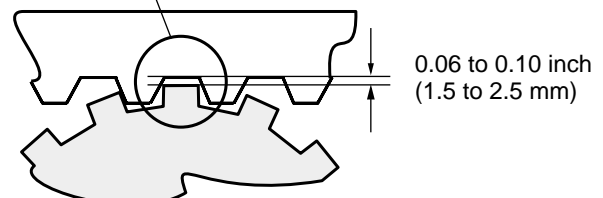
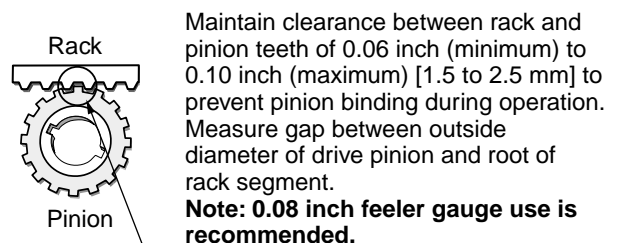

(Dwg. MHP1177)

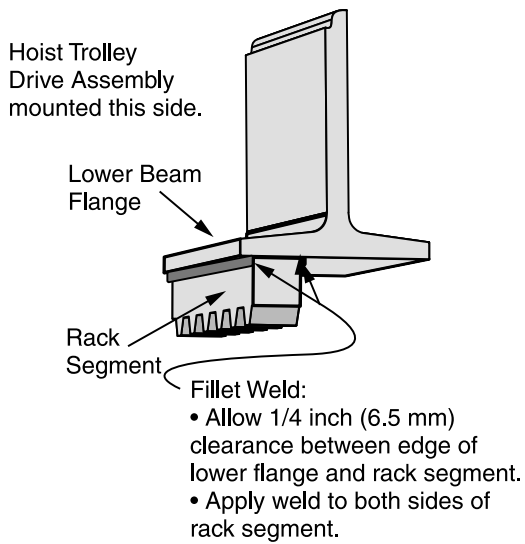

(Dwg. MHP1178)

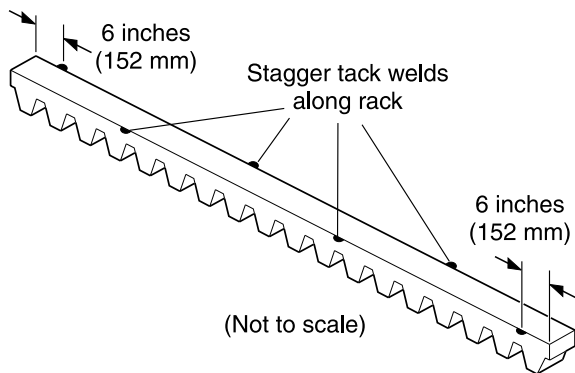

(Dwg. MHP1632)

Rack Drive

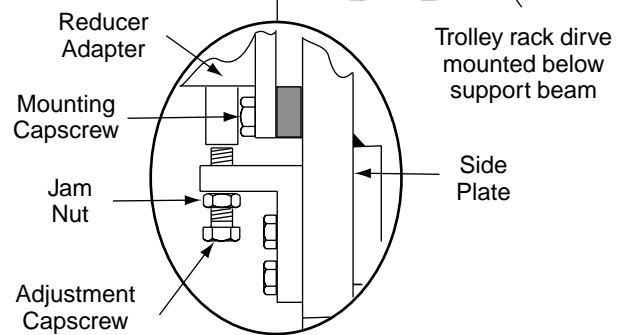
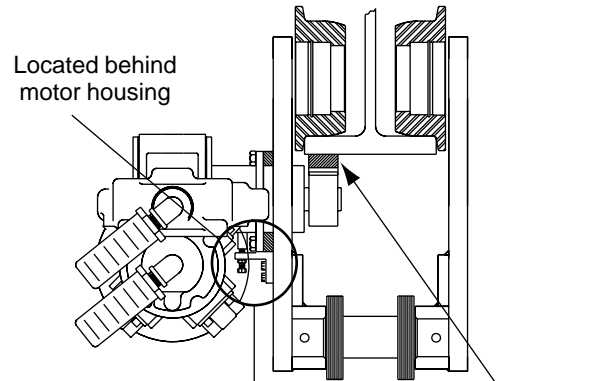
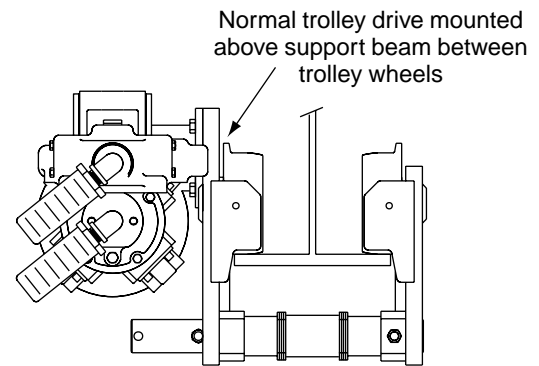

(Dwg. MHP1605)

NOTICE

- Converting from normal trolley drive to Rack Drive requires new sideplates in addition to other items. Contact Technical Support for assistance.

Chain Container

Refer to Dwg. MHP1524 on page 70.

CAUTION

- Adjust container support so that chain container does not contact load chain or hook.
- Operate hoist to naturally pile chain into chain container. Piling chain carelessly into container by hand may lead to kinking or twisting that can cause chain to jam the hoist.

1. Check chain container size to make sure length of load chain is within capacity of chain container. Replace with a larger chain container, if required.
2. Attach chain stopper (241) to last link of load chain free end. Refer to Dwg. MHP0399 on page 71.

3. Attach chain container to hoist.
4. Run bottom block to lowest point and run hoist in up direction to feed chain back into container.

NOTICE

- **When feeding chain into chain container, begin with chain stopper end of chain so that it piles naturally.**

Attaching Free End of Load Chain

Attach free end of load chain to hoist or bottom hook assembly. Refer to Chaining Drawings in “MAINTENANCE” section on page 26.

Air Supply

The air supply must be clean and free from moisture. Due to efficiency losses in air lines and air line components, air pressures should be checked at hoist motor. A minimum of 105 psi (7.2 bar/724 kPa) at hoist motor is required to provide rated hoist capacity. Due to efficiency losses in air lines, pressures of up to 130 psi (8.9 bar/896 kPa) at air supply may be required to achieve required operating pressure. Contact Technical Support Department for operating requirements with optional 60 psi (4 bar/414 kPa) system.

Air Lines

The inside diameter of hoist air supply lines must not be smaller than 1 in. (25 mm) based on a maximum of 50 ft. (15 m) between air supply and hoist. Contact factory for recommended air line sizes for distances greater than 50 ft. (15 m). All air supply lines should be purged before making final connections and connecting to unit inlet. Supply lines should be as short and straight as installation conditions will permit. Long transmission lines and excessive use of fittings, elbows, tees, globe valves etc. cause a reduction in pressure due to restrictions and surface friction in lines.

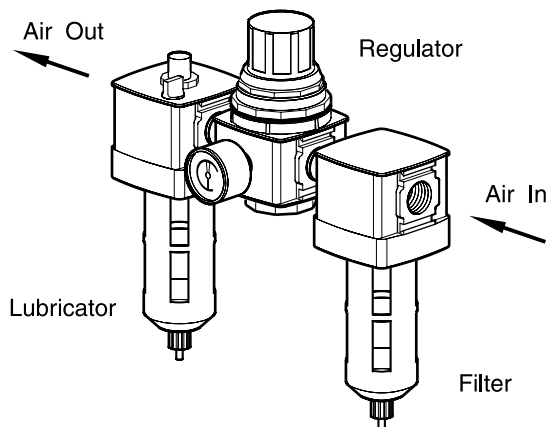

(Dwg. MHP0191)

Air Line Lubricator

Refer to Dwg. MHP0191 on page 11. Always use an air line lubricator with these motors. Use a lubricator having an inlet and outlet at least as large as inlet on motor. Install air line lubricator as close to air inlet on motor as possible.

⚠ CAUTION

- **Lubricator must be located no more than 10 ft. (3 m) from hoist and trolley motors.**

The air line lubricator should be replenished daily and set to provide 4 to 6 drops per minute of ISO VG 32 (10W SAE) oil at maximum motor speed. A fine mist will be exhausted from throttle control valve when operated and air line lubricator is functioning properly.

Air Line Filter

Refer to Dwg. MHP0191 on page 11.

It is recommended that an air line strainer/filter be installed as close as practical to motor air inlet port to prevent dirt from entering motor. The strainer/filter should provide 20 micron filtration and include a moisture trap. Clean strainer/filter periodically to maintain its operating efficiency.

Moisture in Air Lines

Moisture that reaches air motor through supply lines is the chief factor in determining length of time between service overhauls. Moisture traps can help to eliminate moisture and other methods, such as an air receiver which collects moisture before it reaches motor or an aftercooler at compressor that cools the air prior to distribution through supply lines, are also helpful.

Hoist and Trolley Motors

For optimum performance and maximum durability of parts, provide an air supply to operate hoist and trolley motors with 105 psi at 280 scfm (7.2 bar/724 kPa at 8 cu.m/m). The air motor should be installed as near as possible to compressor or air receiver.

* Contact Technical Support Department for operating requirements with optional 60 psi (4 bar/414 kPa system).

Shipping Plug Removal

Remove shipping plugs from brake housing and reducer assembly and trolley drive piston motor 'O' ring, item (360) on Dwg. MHP0381 on page 58 before operating hoist.

⚠ WARNING

- **Failure to remove shipping plugs in brake housing can result in brake malfunction.**

Pendant

Check that all hose connections are tight and that hoses are not twisted or crimped. Refer to Dwg. MHP2234 on page 12 for hose connections. Pendant lengths up to 66 ft (20 m) are available. Contact the factory for pendant lengths greater than 66 ft (20 m).

⚠ CAUTION

- **To avoid damaging the pendant hose, make sure the strain relief cable, not the pendant hose, is supporting the weight of the pendant.**

Single Motor Pendant PHS2E(-U)
(Top View)

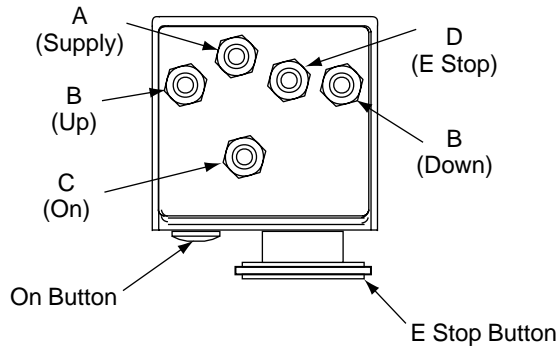

Two Motor Pendant PHS4E(-U)
(Top View)

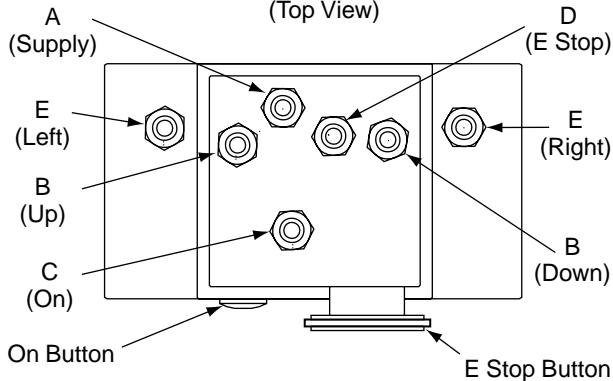

(Dwg. MHP2234)

Pendant (Optional Style)

Pendant control is installed at factory. Hose fittings are color coded to ensure correct assembly. Check all hose connections are tight and that hoses are not twisted or crimped. Refer to Dwg. MHP0094 on page 12 and MHP0095 on page 12 for correct pendant hose connections.

⚠ WARNING

• Do not attempt to reverse air lines either at pendant station or hoist. This will give a false indication of operation which may result in serious damage to hoist.

Manifold Pendant Block
(Viewed from Bottom of Manifold)

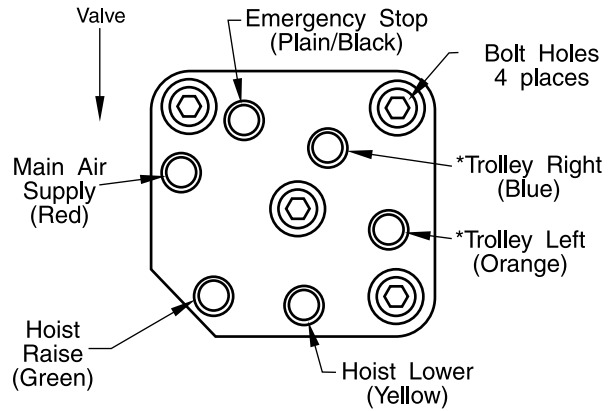

*Plug for Hook-Mounted Units

(Dwg. MHP0094)

Pendant control block shown is for standard pendant assembly illustrated on page 50. Refer to Accu-Trol® Pendant manual (Form number MHD56014) for optional Accu-Trol® Pendant control block.

Pendant Control Block
(Viewed from Top of Block)

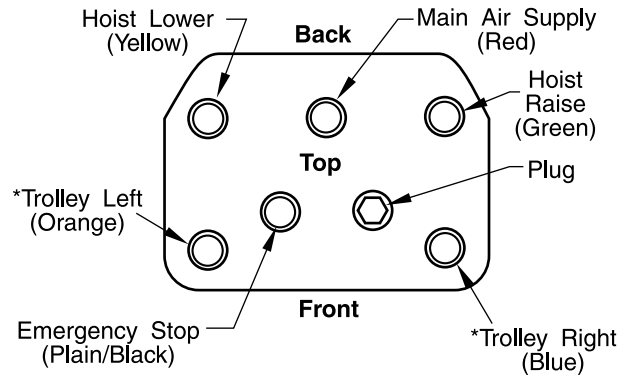

*Plug for Hook-Mounted or non-powered Trolley Units

(Dwg. MHP0095)

⚠ CAUTION

• To avoid damaging pendant hose, make sure strain relief chain, not pendant hose, is supporting weight of pendant.

Check strain relief chain (188) is properly connected to hoist and pendant body.

Emergency Air Shutoff

If supply air is wet and unfiltered, and/or hoist is operated in a dirty environment, hoist or trolley control valves may malfunction and become stuck in "ON" position. As a safeguard, an emergency main line shut-off valve is provided at pendant. The emergency valve shuts off air supply to entire unit when red pull/push button is pressed.

If it is necessary to use emergency air shut off valve, then malfunctioning control valve should be disassembled, cleaned, and/or repaired as required to clear malfunction before resuming operation.

Storing Hoist

For hoists that have been in storage for a period of more than one month the following start-up procedure is required.

1. Give hoist an inspection conforming to requirements of 'Hoists Not in Regular Use' in "INSPECTION" section on page 17.
2. Pour a small amount of ISO VG 32 (10W SAE) oil in motor inlet port.
3. Operate motor for 10 seconds to flush out any impurities.
4. The hoist is now ready to work.

Trolley Drive Assembly Run-In Period

Maximum efficiency of trolley drive worm gear is obtained after a run-in period. The length of time required will depend on load applied and will be 30 minutes to one hour at rated load and considerably longer at lighter loads.

NOTICE

• **Overloading will not decrease run-in time and it may damage worm gear.**

During run-in higher than normal temperature rise and lower efficiency and output torque can be expected.

AIR SCHEMATICS

Hoist without air powered trolley

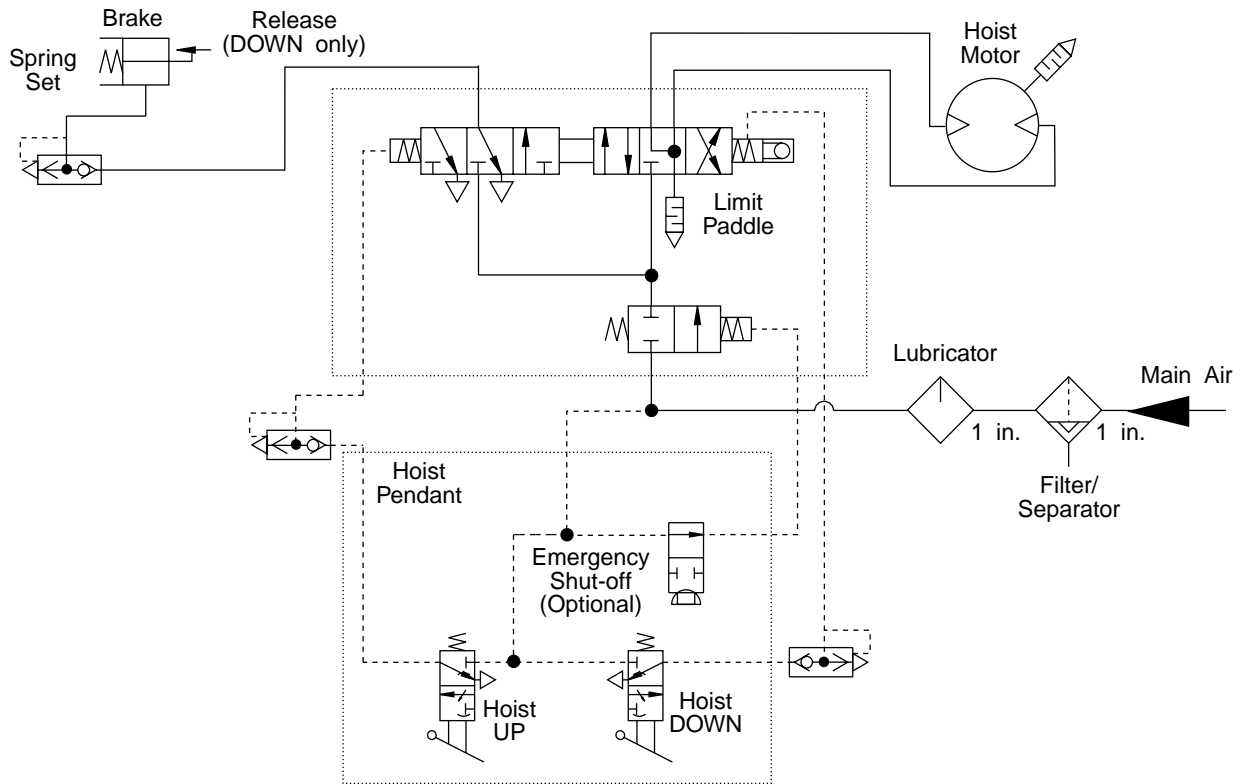

(Dwg. MHP0313)

Hoist with air powered vane or piston motor trolley

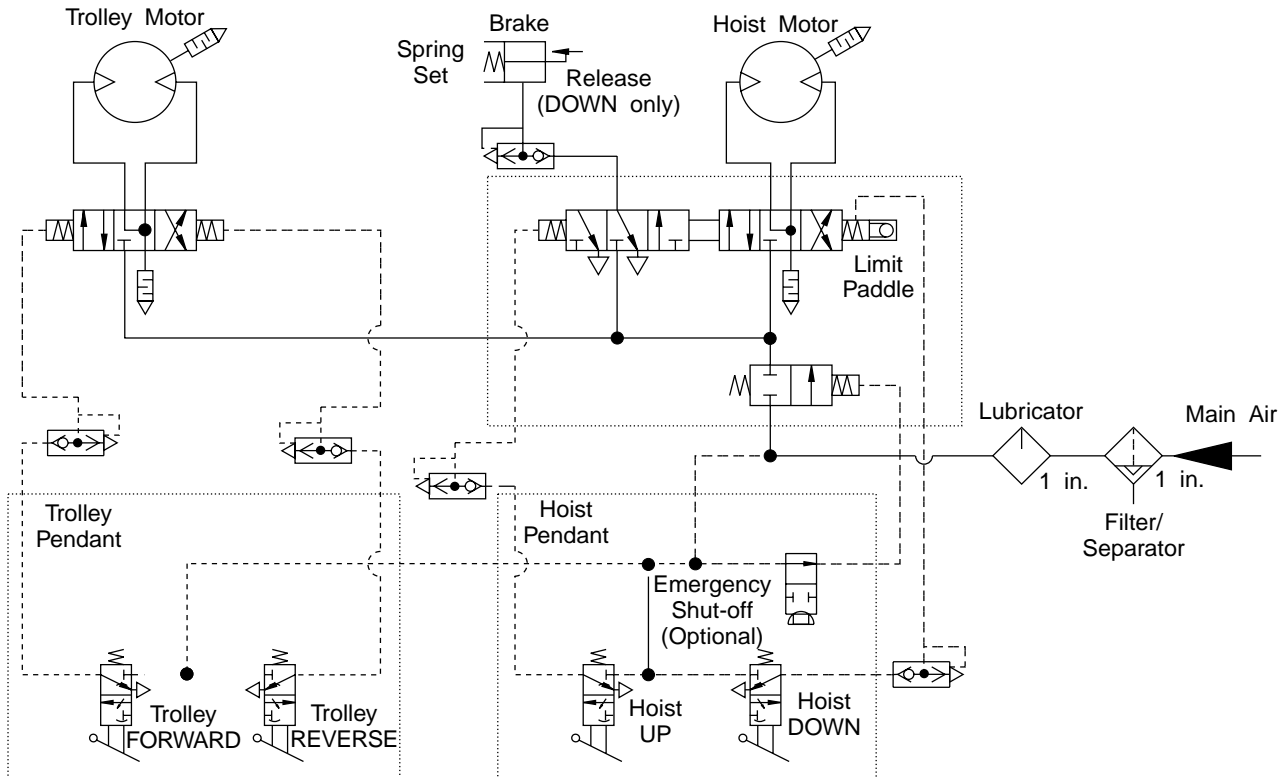

(Dwg. MHP0312)

OPERATION

The four most important aspects of hoist operation are:

1. Follow all safety instructions when operating hoist and trolley.
2. Allow only people trained in safety and operation of this product to operate hoist and trolley.
3. Subject each hoist to a regular inspection and maintenance procedure.
4. Be aware of hoist capacity and weight of load at all times.

WARNING

- **Only allow personnel trained in safety and operation of this product to operate hoist and trolley.**
- **Do not use this hoist for lifting, supporting or transporting people or lifting or supporting loads over people.**

Operators must be physically competent. Operators should have no health condition which might affect their ability to react, and they must have good hearing, vision and depth perception. The hoist operator must be carefully instructed in his duties and must understand operation of hoist, including a study of the manufacturer's literature. The operator must be aware of proper methods of hitching loads and should have a good attitude regarding safety. It is the operator's responsibility to refuse to operate hoist under unsafe conditions.

Initial Operating Checks

Hoists are tested for proper operation prior to leaving factory. Before hoist is placed into service the following initial operating checks should be performed.

1. After installation of trolley mounted hoists, check to ensure hoist is centered below trolley.
2. Check for air leaks in supply hose and fittings to pendant, and from pendant to manifold.
3. When first running hoist or trolley motors a small amount of light oil should be injected into inlet connection to allow good lubrication.
4. When first operating hoist and trolley it is recommended that motors be driven slowly in both directions for a few minutes.
5. Operate trolley along entire length of beam.
6. Inspect hoist and trolley performance when raising, moving and lowering test load(s). Hoist and trolley must operate smoothly and at rated specifications prior to being placed in service.
7. Check that trolley (if equipped) and hook movement is in same direction as arrows or information on pendant control.
8. Raise and lower a light load to check operation of hoist brake.
9. Check hoist operation by raising and lowering a load equal to rated capacity of hoist 4 to 6 inches (100 to 150 mm) off floor.
10. Check operation of limit devices.
11. On trolley units, check 'O' ring (360) on breather plug (362) in trolley drive piston motor has been removed.
12. Check that solid plug (necessary only for shipping) is removed from power head reduction gear assembly and replaced with breather (421) attached to notice tag supplied with hoist.

Hoist Controls

Pendant

The pendant can have from two to six levers. The two-lever pendant will control hoist movement up and down. A four-lever pendant will control trolley movement and hoist operation. A six-lever pendant would include the above movements plus control a bridge assembly allowing hoist movement in four directions. Always apply smooth even pressure to pendant levers, avoid quick starts and abrupt stops. This will allow safer control of suspended loads and reduce stress on components.

Two Lever Pendant Operation

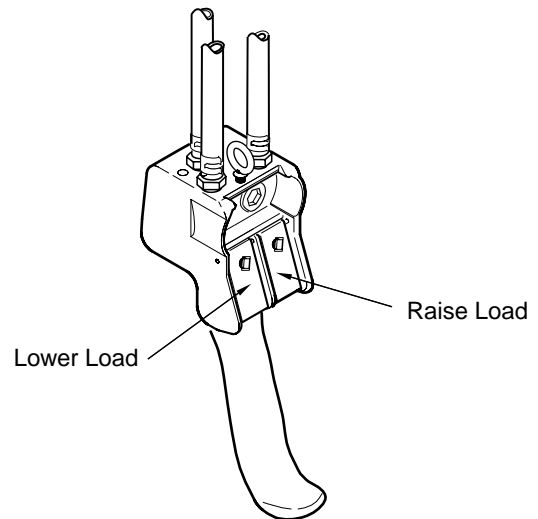

(Dwg. MHP2299)

Operation of hoist is same for all pendants listed in this section:

1. To lift a load, depress hoist pendant raise lever.
2. To lower a load depress hoist pendant lower lever.
3. To throttle lift or lowering speed, regulate the amount pendant lever is depressed. Depress lever completely for maximum speed; depress lever partially for slower speeds.
4. To stop lift or lowering function, release lever. Lever will spring back to "OFF" and hoist motor will stop.

Single Function, Two Lever Pendant

Refer to Dwg. MHP0427 on page 16.

The two lever pendant is standard pendant supplied with hook mounted hoists and is designed to provide hoist operation only. Hoist operation must correspond to directions indicated by arrows located on pendant levers.

Two Lever Pendant Operation (old style)

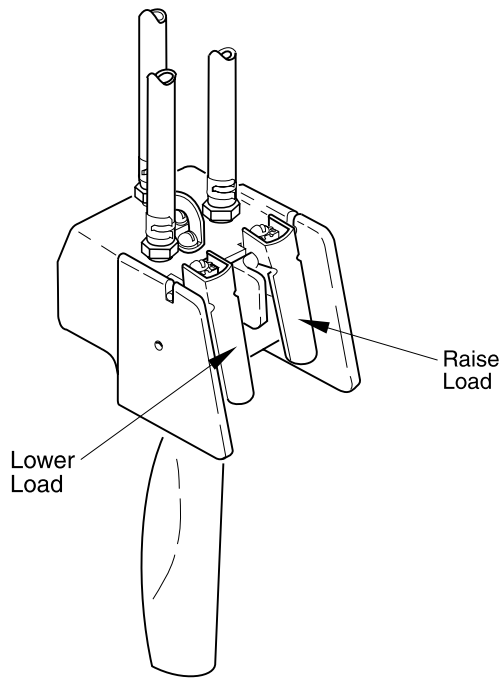

(Dwg. MHP0427)

Emergency Stop (optional feature)

The Emergency Stop button, when activated, will immediately stop all operations of the trolley and hoist. The Emergency Stop button will remain depressed after activation. To reset Emergency Stop button, twist (rotate) Emergency Stop button clockwise until button releases and spring returns to its original position. Depress "ON" button.

Two Lever Pendant with Emergency Stop Operation

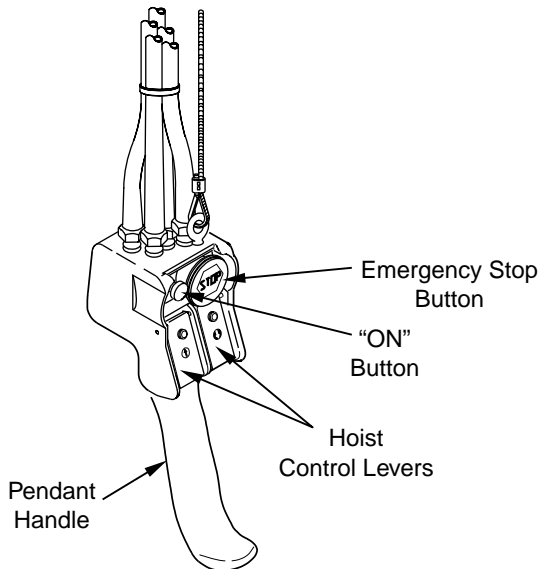

(Dwg. MHP1649)

Four Lever Pendant with Emergency Stop Operation

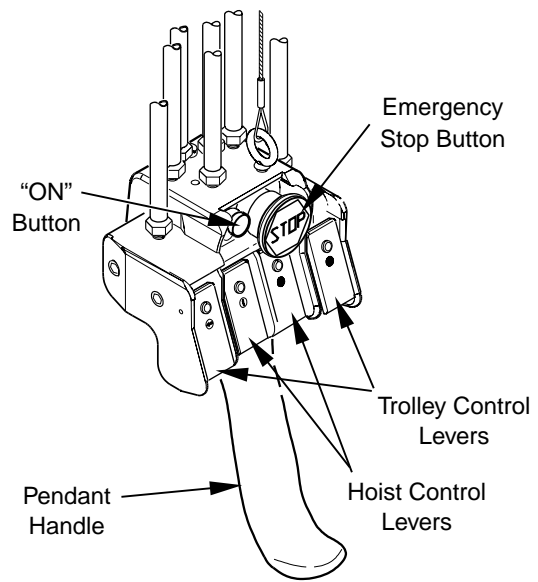

(Dwg. MHP1547)

Pilot Pendant Throttle with Emergency Stop (Old Style)

Refer to Dwg. MHP0395 on page 16.

The pendant control throttle is equipped with two separate levers for hoist operation. Pilot pressure from pendant throttle activates hoist control valve. Direction of hook travel is controlled by whichever lever is pressed.

Trolley operation is controlled by two buttons located above hoist control levers.

Additionally, an emergency shut-off feature is available on this pendant model.

Four Lever Pendant with Emergency Stop Operation

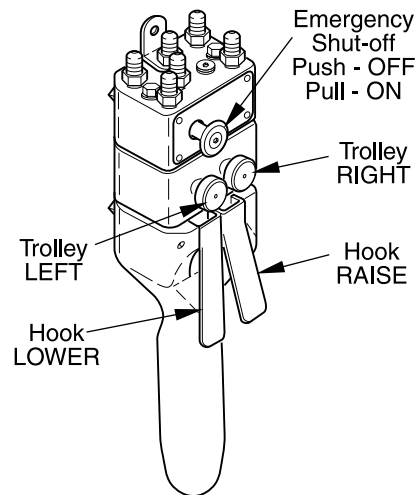

(Dwg. MHP0395)

Accu-Trol® Pendant (Push Button Type)

The optional Accu-Trol® Pendant is available with 2, 4 or 6 buttons. Refer to Accu-Trol® Pendant manual form number MHD56014 for additional information.

Accu-Trol® Pendant Operation

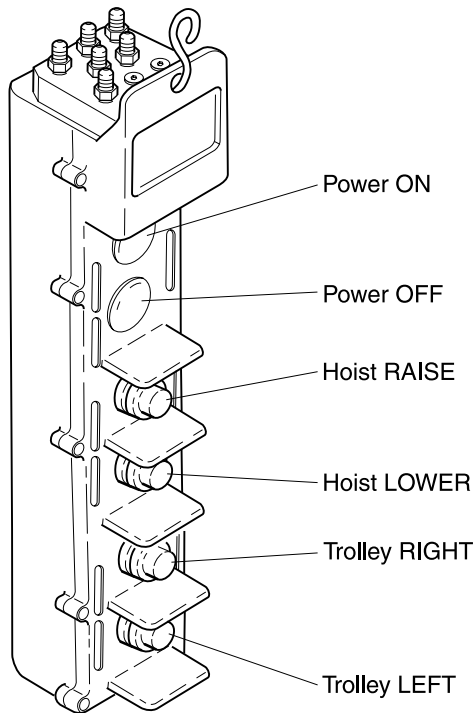

(Dwg. MHP0434)

Pull Rope

The hoist can be supplied with an optional manual pull rope control.

The pull rope provides operator with a local hoist operating station. The following operating directions are as viewed facing motor end of hoist.

1. To LIFT a load pull down on RIGHT pull rope.
2. To LOWER a load pull down on LEFT pull rope.
3. Pull rope to full travel for maximum speed; pull rope partially for slower speeds.
4. To stop lift or lowering of load, release pull rope. Hoist motor will stop.

Pull Rope Operation

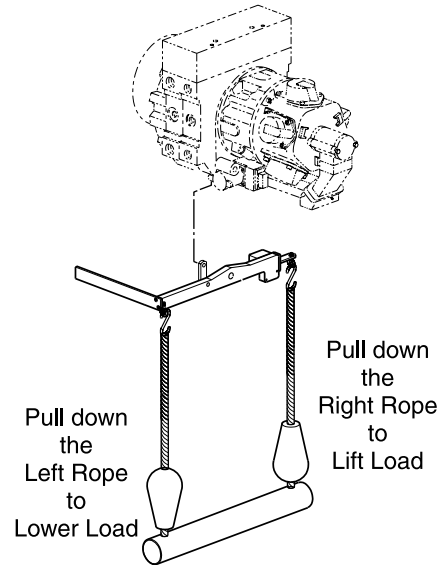

(Dwg. MHP1704)

INSPECTION

Inspection information is based in part on American National Standards Institute Safety Codes (ASME B30.16).

⚠ WARNING

- All new, altered or modified equipment should be inspected and tested by personnel instructed in safety, operation and maintenance of this equipment to ensure safe operation at rated specifications before placing equipment in service.
- Never use a hoist that inspection indicates is damaged.

Frequent and periodic inspections should be performed on equipment in regular service. Frequent inspections are visual examinations performed by operators or personnel trained in safety and operation of this equipment and include observations made during routine hoist operation. Periodic inspections are thorough inspections conducted by personnel trained in safety, operation and maintenance of this equipment.

ASME B30.16 states inspection intervals depend upon the nature of the critical components of equipment and severity of usage. The inspection intervals recommended in this manual are based on intermittent operation of hoist eight hours each day, five days per week, in an environment relatively free of dust, moisture and corrosive fumes. If hoist is operated almost continuously or more than eight hours each day, more frequent inspections will be required.

Careful inspection on a regular basis will reveal potentially dangerous conditions while still in the early stages, allowing corrective action to be taken before condition becomes dangerous.

Deficiencies revealed through inspection, or noted during operation, must be reported to designated personnel instructed in safety, operation and maintenance of this equipment. A determination as to whether a condition constitutes a safety hazard must be made, and correction of noted safety hazards accomplished and documented by written report before placing equipment in service.

Records and Reports

Inspection records, listing all points requiring periodic inspection should be maintained for all load bearing equipment. Written reports, based on severity of service, should be made on the condition of critical parts as a method of documenting **periodic** inspections. These reports should be dated, signed by person who performed inspection, and kept on file where they are readily available for review.

Load Chain Reports

Records should be maintained documenting condition of load chain removed from service as part of a long-range load chain inspection program. Accurate records will establish a relationship between visual observations noted during frequent inspections and

actual condition of load chain as determined by periodic inspection methods.

Frequent Inspection

On hoists in continuous service, frequent inspection should be made at the beginning of each shift. In addition, visual inspections should be conducted during regular service for any damage or evidence of malfunction.

1. **OPERATION.** Check for visual signs or abnormal noises (grinding etc.) which could indicate a problem. Make sure all controls function properly and return to neutral when released. Check chain feed through hoist and bottom block. If chain binds, jumps, is excessively noisy or 'clicks', clean and lubricate chain. If problem persists, replace chain. Operate trolley along entire length of beam. Trolley should operate smoothly without sticking or binding. Do not operate hoist until all problems have been corrected.
2. **HOOKS.** Check for wear or damage, increased throat width, bent shank or twisting of hook. Replace hooks which exceed throat opening discard width specified in Table 2 (refer to Dwg. MHP0040 on page 18) or exceed a 10° (degree) twist (refer to Dwg. MHP0111 on page 18). If hook latch snaps past tip of hook, hook is sprung and must be replaced. Refer to the latest edition of ASME B30.10 "HOOKS" for additional information.

Hook Throat Width

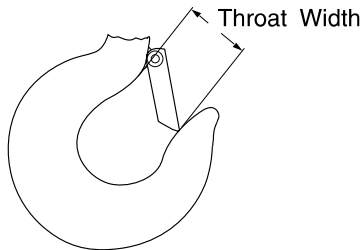

(Dwg. MHP0040)

Table 2 — Hook Throat Normal and Discard Width

Hoist Model	Hook Type	Throat Width		Discard Width	
		in.	mm	in.	mm
HA2-012	Standard	2.5	63.5	2.87	73
HA2-025		4.0	101.6	4.6	116.8
HA2-037		4.75	120.6	5.46	138.7
HA2-050		6.5	165.1	7.47	189.8

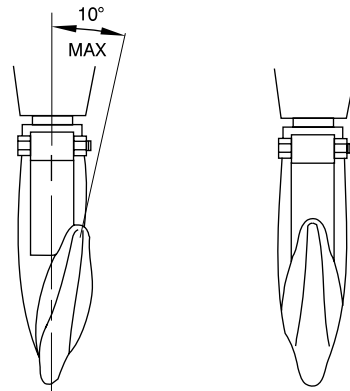

(Dwg. MHP0111)

3. **UPPER AND LOWER LIMIT DEVICE.** Test operation with no load. Upward travel must stop when bottom block hits hoist limit arm. Downward travel must stop when stop buffer at unloaded end of chain activates limit arm.
4. **AIR SYSTEM.** Visually inspect all connections, fittings, hoses and components for indication of air leaks. Repair any leaks found.
5. **CONTROLS.** During operation of hoist and/or trolley, verify response to pendant is quick and smooth. If response is slow or movement is unsatisfactory, do not operate hoist until all problems have been corrected.
6. **HOOK LATCH.** Make sure hook latch is present and operating. Replace if necessary.
7. **CHAIN.** Examine each of links for bending, cracks in weld areas or shoulders, traverse nicks and gouges, weld splatter, corrosion pits, striation (minute parallel lines) and chain wear, including load bearing surfaces between chain links, refer to Dwg. MHP0102 on page 18. Replace a chain that fails any of inspections. Check chain lubrication and lubricate if necessary. Refer to 'Load Chain' in "LUBRICATION" section on page 21.

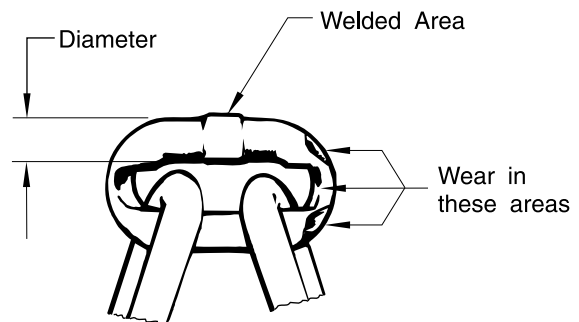

(Dwg. MHP0102)

NOTICE

• **The full extent of load chain wear cannot be determined by visual inspection. At any indication of load chain wear inspect chain and chain wheel in accordance with instructions in 'Load Chain' listed in "Periodic Inspection."**

8. **LOAD CHAIN REEVING.** Ensure welds on standing links are away from load sheave. Reinstall chain if necessary. Make sure chain is not capsized, twisted or kinked. Adjust as required. Refer to "MAINTENANCE" section on page 26.

Periodic Inspection

According to ASME B30.16, frequency of periodic inspection depends on the severity of usage:

NORMAL	HEAVY	SEVERE
yearly	semiannually	quarterly

Disassembly may be required for HEAVY or SEVERE usage. Keep accumulative written records of periodic inspections to provide a basis for continuing evaluation.

Inspect all the items in “Frequent Inspection.” Also inspect the following:

1. **FASTENERS.** Check all rivets, split pins, capscrews and nuts. Replace if missing or tighten if loose.
2. **ALL COMPONENTS.** Inspect for wear, damage, distortion, deformation and cleanliness. If external evidence indicates the need, disassemble. Check gears, shafts, bearings, sheaves, chain guides, springs and covers. Replace worn or damaged parts. Clean, lubricate and reassemble.
3. **HOOKS.** Inspect hooks carefully for cracks using magnetic particle or other suitable non-destructive method. Inspect hook retaining parts. Tighten, repair or replace if necessary.
4. **LOAD CHAIN SHEAVES.** Check for damage or excessive wear. Replace if necessary. Observe the action of load chain feeding through hoist. Do not operate a hoist unless load chain feeds through hoist and hook block smoothly and without audible clicking or other evidence of binding or malfunctioning.
5. **MOTOR.** If performance is poor, disassemble motor and check for wear or damage to bearings and shafts. The parts should be cleaned, lubricated and reassembled. Replace worn or damaged parts.
6. **BRAKE.** Raise a load equal to rated capacity of hoist 4 to 6 inches (100 to 150 mm) off floor and check ability of hoist to hold load without drift. If drift occurs, disassemble. Remove brake discs as described in the “MAINTENANCE” section on page 26. Check and clean brake parts each time hoist is disassembled. Replace brake friction discs if thickness is less than 0.072 inch (1.83 mm), or if oil groove pattern is not clearly visible.
7. **SUPPORTING STRUCTURE.** Check for distortion, wear and continued ability to support load.
8. **TROLLEY.** Check that trolley wheels track beam properly and clearance between trolley wheel flanges and beam is correct. Refer to “INSTALLATION” section on page 8. Check that wheels and beam are not excessively worn. Inspect side plates for spreading due to bending. Do not operate hoist until problems have been corrected.
9. **LABELS AND TAGS.** Check for presence and legibility. Replace if necessary.
10. **END ANCHORS (Load chain).** Ensure load chain end is securely attached. Check chain stopper is correctly installed on free end of load chain.
11. **LOAD CHAIN.** Measure chain for stretching by measuring across five link sections all along chain, paying particular attention to most frequently reeved links. Refer to Dwg. MHP0041 on page 19. When any five-link section in working length reaches or exceeds discard length, listed in Table 3 on page 19, replace entire chain. Always use genuine **Ingersoll-Rand** replacement chain for regular and nickel-diffused load chains. When ordering load chain, specify which unit it will be used on. Chain will then be cut and tagged with the right number of links.

Table 3 — Load Chain Normal and Discard Length

Hoist Model	Chain Size	Normal Length		Discard Length	
	mm	in.	mm	in.	mm
HA2-012	22	13.05	331	13.22	336
HA2-025					
HA2-037					
HA2-050					

Load Chain Length—Inspection

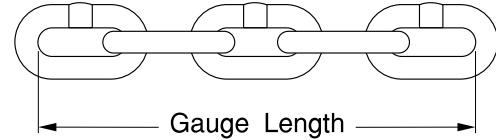

(Dwg. MHP0041)

12. **CHAIN CONTAINER.** Check for damage or excessive wear and that chain container is securely attached to hoist. Secure or replace if necessary.
13. **LIMIT ASSEMBLY.** Check limit arm moves freely.

Hoists Not in Regular Use

1. Hoists which have been idle for a period of one month or more, but less than one year, should be given an inspection conforming with the requirements of “Frequent Inspection” prior to being placed into service.
2. Hoists which have been idle for a period of more than one year should be given an inspection conforming with the requirements of “Periodic Inspection” prior to being placed into service.
3. Standby hoists should be inspected at least semiannually in accordance with the requirements of “Frequent Inspection.” In abnormal operating conditions hoists should be inspected at shorter intervals.

INSPECTION AND MAINTENANCE REPORT

Ingersoll-Rand HA2 Air Hoist

Model Number:	Date:
Serial Number:	
Reason for Inspection: (Check Applicable Box)	Inspected By:
<input type="checkbox"/> 1. Scheduled Periodic Inspection (_____ Quarterly _____ Semiannually _____ Yearly)	Operating Environment: Normal _____ Heavy _____ Severe _____
<input type="checkbox"/> 2. Discrepancy(s) noted during Frequent Inspection	
<input type="checkbox"/> 3. Discrepancy(s) noted during maintenance	
<input type="checkbox"/> 4. Other: _____	

Refer to Parts, Operation and Maintenance Manual "INSPECTION" section on page 17 and to the appropriate National Standards and Codes of practice for general inspection criteria. If in doubt about an existing condition, contact the nearest **Ingersoll-Rand** distributor or factory for technical assistance.

COMPONENT	CONDITION		CORRECTIVE ACTION		NOTES
	Pass	Fail	Repair	Replace	
Fasteners					
Gears					
Shafts					
Bearings			---		
Load Bearing Sheaves					
Chain Guides					
Springs			---		
Covers					
Hooks			---		
Top	Actual Hook Throat Width: _____ inches / _____ mm (Refer to Table 2 on page 18 for max. acceptable widths.)				
	Hook Twist			---	(maximum 10%)
	Hook Crack Test Method Used: Dye Penetrant _____ Magnetic Particle _____ Other: _____				
Bottom	Actual Hook Throat Width: _____ inches / _____ mm (Refer to Table 2 on page 18 for max. acceptable widths.)				
	Hook Twist			---	(maximum 10%)
	Hook Crack Test Method Used: Dye Penetrant _____ Magnetic Particle _____ Other: _____				
Hook Latch			---		
Brake (10% Load Test)			---		
Brake (Visual Inspection)					
Tail Pin (End Anchor)					
Load Chain					
	Working length(s) maximum wear: _____ inches / _____ mm (refer to Table 3 on page 19)				
Supporting Structure					
Labels and Tags			---		
Other Components (List in NOTES section)					

Testing:	Pass	Fail	NOTES
Operational (No Load)			
Operational (10% Load)			
Operational (Maximum Test Load*)			

* Refer to 'Load Test' in "MAINTENANCE" section on page 38 for testing information.

This page may be photocopied and used by inspectors or maintenance personnel.

LUBRICATION

To ensure continued satisfactory operation of hoist, all points requiring lubrication must be serviced with correct lubricant at the proper time interval as indicated for each assembly. Correct lubrication is one of the most important factors in maintaining efficient operation.

The lubrication intervals recommended in this manual are based on intermittent operation of hoist eight hours each day, five days per week. If hoist is operated almost continuously or more than eight hours each day, more frequent lubrication will be required. Also, lubricant types and change intervals are based on operation in an environment relatively free of dust, moisture, and corrosive fumes. Use only those lubricants recommended. Other lubricants may affect performance of hoist. Approval for use of other lubricants must be obtained from your **Ingersoll-Rand** Technical Support Department or distributor. Failure to observe this precaution may result in damage to hoist and/or its associated components.

INTERVAL	LUBRICATION CHECKS
Start of each shift	Check flow and level of air line lubricator (approximately 4 to 6 drops per minute required at maximum motor speed).
	Check oil levels in hoist and trolley piston motors.
Monthly	Inspect and clean or replace air line filter.
	Lubricate all grease fittings.
	Check oil level in brake and reduction gear assembly.
Semiannually	Drain and replace oil in trolley and hoist piston drive motors.
Yearly	Drain and refill oil in hoist brake and reduction gear assembly.

Pivot Points and Bushings

Lubricate grease fittings monthly with 2 or 3 pumps from a grease gun or more frequently, depending on severity of service.

Table 4 — Recommended Lubricants

Ambient Temperature	Recommended Grease Type
-20° to 50° F (-30° to 10° C)	EP 1 multipurpose lithium-based
30° to 120° F (-1° to 49° C)	EP 2 multipurpose lithium-based

Hoist Motor

The motor is splash lubricated by oil in motor housing and has no other means of lubrication. It is therefore important to use only high quality, rust- and oxidation-inhibiting lubricant to ensure maximum performance and minimum downtime for repairs. Refer to Table 5 on page 21 for recommended oil type. Allow oil to settle prior to topping off. Oil capacity for HA2 hoist motor is 0.2 gals (0.76 lbs).

Table 5 — Hoist Motor Recommended Oil

Ambient Temperature	Recommended Oil Type
Below 32° F (0° C)	ISO VG 32 (10W SAE)
30° to 80° F (0° to 26° C)	ISO VG 68 (20W SAE)*
Above 80° F (26° C)	ISO VG 100 (30W SAE)

* Hoists are shipped from factory with ISO VG 68 (20W SAE) oil.

Piston Trolley Drive Motor

The motor is splash lubricated by oil in motor housing and has no other means of lubrication. It is therefore important to use only high quality, rust and oxidation-inhibiting lubricant to insure maximum performance and minimum down time for repairs. Allow oil to settle prior to topping off. Oil capacity for HA2 trolley drive motor is 0.1 pints (65 ml). Refer to Table 6 for recommended oil.

Table 6 — Piston Trolley Motor Recommended Oil

Ambient Temperature	Recommended Oil Type
Below 32° F (0° C)	ISO VG 68 (20W SAE)
30° to 80° F (0° to 26° C)	ISO VG 100 (30W SAE)*
Above 80° F (26° C)	ISO VG 150 (40W SAE)

* Trolley Motors are shipped from factory with ISO VG 100 (30W SAE) oil.

Bottom Hook Block Assembly

Refer to Dwgs. MHP0314, MH P0315, MHP0316 and MHP0317 on pages 68 and 69.

To prevent moisture entering bottom block assemblies they should periodically be disassembled and repacked with grease. Apply grease to grease fitting until grease escapes through breather (421). Refer to Table 4 on page 21 for recommended grease types at specific temperature ranges. Refer to Table 7 on page 21 for required quantity of grease.

Table 7 — Bottom Hook Lubrication Quantities

Hoist Model	Capacity metric tons	Grease Required to Pack Hook Assembly	
		oz	grams
HA2-012	12.5	1.1	31
HA2-025	25	7.2	204
HA2-037	37.5	16.5	468
HA2-050	50	30.8	873

Load Chain



• Failure to maintain clean and well lubricated load chain will result in rapid load chain wear that can lead to chain failure which can cause severe injury, death or substantial property damage.

1. Lubricate load chain weekly, or more frequently, depending on severity of service.
2. In a corrosive environment, lubricate more frequently than normal.
3. Lubricate each link of load chain and apply new lubricant over existing layer.
4. Lubricate hook and hook latch pivot points.
5. If required, clean chain with acid free solvent to remove rust or abrasive dust build-up and lubricate chain.
6. Use **Ingersoll-Rand LUBRI-LINK-GREEN®** or an ISO VG 320 to 220 (SAE 50 to 90 EP) oil.

Trolley Drive Assembly

Refer to Dwg. MHP0306 on page 64.

The gear housing is filled at the factory and shipped with oil, a non-toxic, high quality, Extreme Pressure (EP), rust- and oxidation-inhibiting worm gear AGMA #7 lubricant that is suitable for an ambient temperature of 50° F to 125° F (10° C to 52° C).

Before placing hoist in operation, make certain that vented pipe plug (210) has been installed in gear housing (212).

Fill gear housing (212) through vented fill plug (210) hole to height of level plug (201) hole located in cover (202). The gear housing oil capacity is approximately 0.4 gals (1.5 lts.).

After first 10 hours of operation oil should be changed. Thereafter it should be changed every 100 hours of service or every 6 months, whichever occurs first.

The oil is drained by removing pipe plug (213) located underneath gear housing (212). If oil drains too slowly, removing vented fill plug (210) may speed up draining. The oil should be replaced using one of the recommended lubricants or its equivalent.

Table 8 — Trolley Drive Recommended Lubricants

Ambient Temperature	Recommended Lubricant
-10° to 50° F (-23° to 10° C)	AGMA #5 (EP 5)
50° to 125° F (10° to 52° C)	AGMA #7 (EP 7)

Reduction Gear Assembly

The reduction gear assembly is shipped with oil from the factory. Check oil level before initial hoist operation. If hoist is used at a normal frequency replace oil in reduction housing once every year.

To ensure correct performance, highest efficiency and long life, it is essential that lubricating oil be maintained at correct level. Oil capacity for reduction gear assembly is 1.1 gals (4.2 lts).



• Do not over fill. Excess oil will reduce operating efficiency and increase oil temperature.

Use only high quality lubricants in reduction gear assembly such as ISO VG 200 EP motor oil or high grade EP4 gear oil.

The recommended grade of oil must be used at all times since use of unsuitable oil may result in excessive temperature rise, loss of efficiency and possible damage to gears. Check vented fill plug is unrestricted.

Table 9 — Reduction Gear Recommended Lubricants

Ambient Temperature	Recommended Lubricant
Below 32° F (0° C)	
30° to 80° F (0° to 26° C)	
Above 80° F (26° C)	ISO VG 200 EP

Reduction Gear Level and Fill Plug Locations

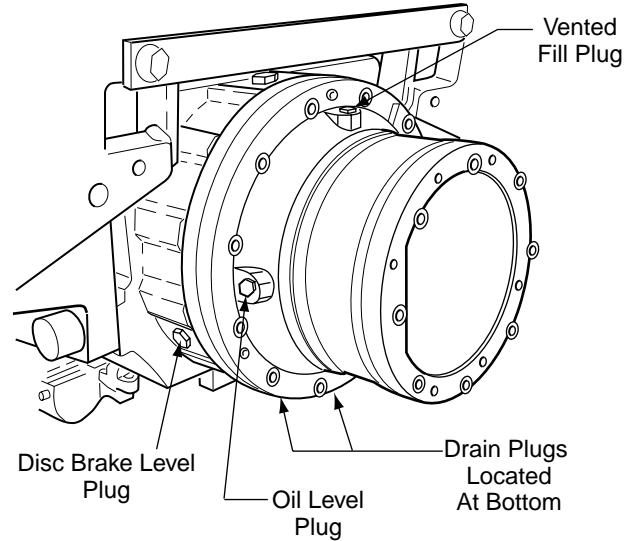

(Dwg. MHP0343)

Disc Brake

Refer to Dwg. MHP0353 on page 40.

The disc brake housing is filled and shipped with oil from the factory. Check oil level before initial hoist operation. If hoist is used at a normal frequency replace oil in disc brake housing once every year.

To ensure correct performance, highest efficiency and long life, it is essential that lubricating oil be maintained at correct level. Oil capacity for disc brake housing is 0.2 gals (0.76 lts).



• Do not over fill. Excess oil will reduce operating efficiency and increase oil temperature.

Use only high quality lubricants in disc brake housing assembly such as ISO VG 200 EP motor oil or high grade EP4 type gear oil.

The recommended grade of oil must be used at all times since use of unsuitable oil may result in excessive temperature rise, loss of efficiency and possible damage to brake discs and sprig clutch.

Fill brake housing (27) to height of level plug (28).

Table 10 — Disc Brake recommended Lubricants

Ambient Temperature	Recommended Lubricant
Below 32° F (0° C)	
30° to 80° F (0° to 26° C)	
Above 80° F (26° C)	ISO VG 200 EP

Seals and Bearings

If hoist is disassembled, clean all parts thoroughly and coat bearings and seals with clean grease. Use sufficient grease to

provide a good protective coat. Lubricate grease fittings monthly with 2 or 3 pumps of a grease gun. For correct grease type, refer to Table 4 on page 21.

Hoist Lubrication Points

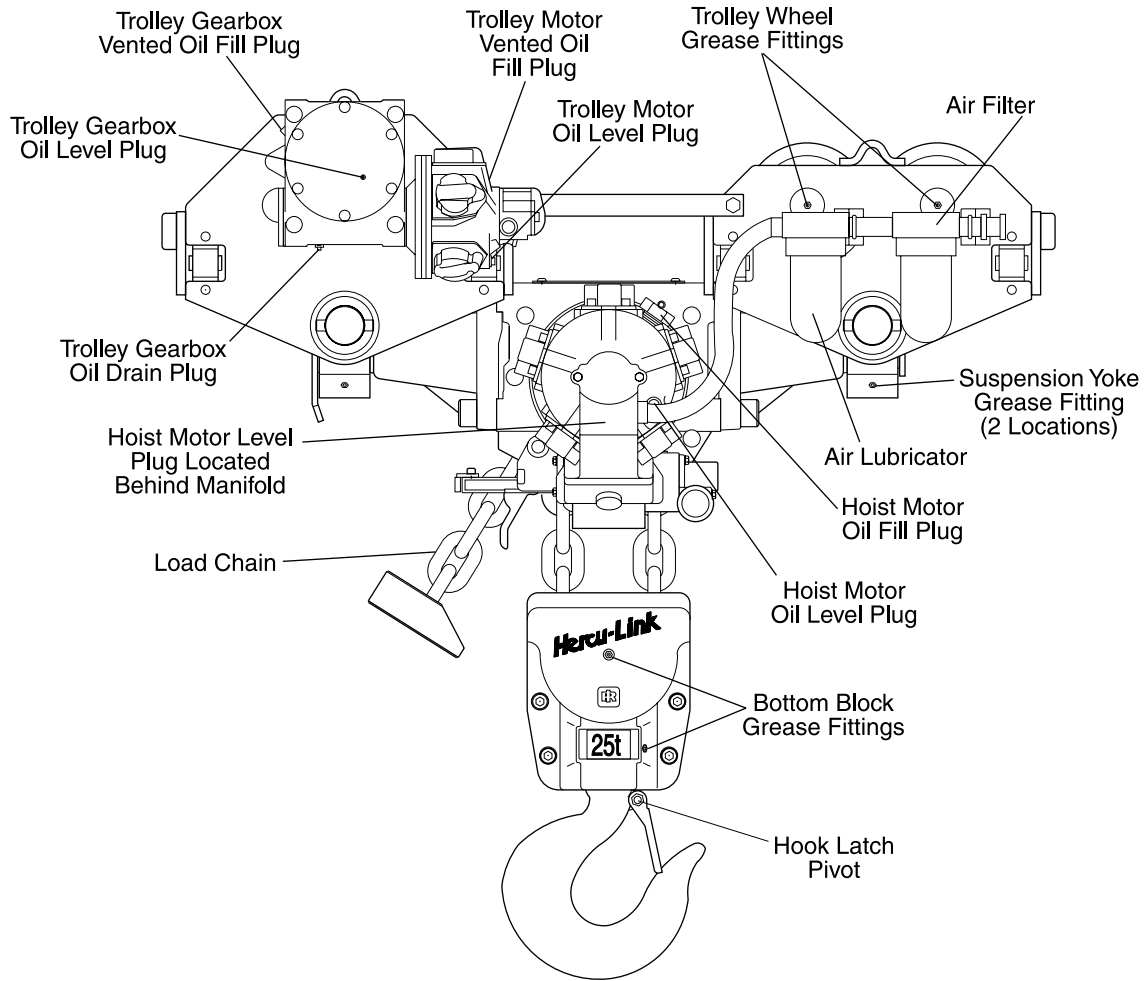

(Dwg. MHP0338)

TROUBLESHOOTING

This section provides basic troubleshooting information. Determination of specific causes to problems are best identified by thorough inspections performed by personnel instructed in safety, operation and maintenance of this equipment. The chart below provides a brief guide to common hoist symptoms, probable causes and remedies.

Symptom	Cause	Remedy
Hoist will not operate.	No air supply to hoist, or too little CFM or PSI.	Check PSI (bar) at hoist inlet. Refer to "SPECIFICATIONS" section on page 7 for correct CFM (cu.m/min) and PSI (bar).
	Valve or limit arm sticking.	Check limit arm for free movement.
	Emergency stop valve "OFF".	Reset Emergency stop and push "ON" button.
	Pendant malfunction.	Check PSI (bar) at pendant. Minimum operating pressure in pendant line is 55 PSI (380 kPa/3.8 bar).
	Hoist is overloaded.	Reduce load to within rated capacity.
	Motor is damaged.	Repair or replace. Refer to "MAINTENANCE" section on page 26. Check oil level in motor and gearbox.
	Lubricator is low on oil.	Fill lubricator.
	Brake is not releasing ("DOWN" direction only).	Check brake release circuit and PSI (bar) at brake inlet (55 PSI (380 kPa/3.8 bar) minimum).
Load continues to move when hoist is stopped. "UP" direction.	Valve or limit arm sticking.	Check limit arm for free movement.
	Dump valves not releasing.	Check pendant hose dump valves.
	Pendant lever sticking.	Check lever and restore free movement.
Load continues to move when hoist is stopped. "DOWN" direction.	Valve or limit arm sticking.	Check limit arm for free movement.
	Dump valves not releasing.	Check pendant hose dump valves.
	Brake is slipping.	Check brake springs and brake disc linings for wear. Refer to "MAINTENANCE" section on page 26.
	Break release screws incorrectly set. (old style hoists)	Check brake release screws in brake housing. Adjust as needed: Refer to Dwg. MHP0397 on page 34.
	Hoist is overloaded.	Reduce load to within rated capacity.
	Pendant lever sticking.	Check lever and restore free movement.
Hoist will not lift rated capacity.	Hoist is overloaded.	Reduce load to within rated capacity.
	No air supply to hoist or too little CFM or PSI.	Check PSI (bar) at hoist inlet. Refer to "SPECIFICATIONS" section on page 7 for correct CFM (cu.m/min) and PSI (bar).
	Main air valve travel is restricted.	Check limit arm and linkage for free movement.
	Exhaust is restricted.	Inspect vents and replace muffler.
	Motor is damaged.	Check for worn motor bearings. Repair as needed.
	Motor or gearbox is out of oil.	Check oil levels in motor and gearbox. Fill to recommended level.
Hook can be lowered but not raised.	Hoist is overloaded.	Reduce load to within rated capacity.
	No air supply to hoist or too little CFM or PSI.	Check at hoist power supply connection with hoist under load. Raise pressure to rated capacity.
	Pendant malfunction.	Check PSI (bar) at air inlet connection (green fitting) on pendant.
Hook can be raised but not lowered.	Brake is not releasing.	Check PSI (bar) at brake inlet. (55 PSI (380 kPa/3.8 bar) minimum.) Check brake and pendant dump valves.
	No breather in gearbox.	Remove solid square head plug in outboard end of gearbox only and install vented (breather) plug.
	Brake piston seals leaking (old style).	Install upgrade kit. Refer to Parts section.
	Low air pressure.	Check PSI (bar) at valve inlet. Raise pressure to rated capacity.
	Pendant malfunction.	Check PSI (bar) at yellow fitting connection on pendant.

Symptom	Cause	Remedy
Load chain jumps on sheave or is making a snapping sound.	Worn or rusted chain.	Refer to “INSPECTION” section on page 19 to determine wear limit. Replace if necessary.
	Incorrect chain.	Replace with correct chain.
	Worn sheave or chain guide.	Replace worn parts.
	Capsized hook.	Correct as described in “MAINTENANCE” section on page 27.
	Hoist not in line with load.	Align hoist with load. Do not “yard” or “side pull.”
	Incorrectly reeved load chain.	Check load chain is correctly reeved.
	No oil on load chain.	Lubricate load chain.

Trolley

Trolley will not stop or trolley wheels slip.	Damaged beam.	Repair or replace beam.
	Excessive oil, grease or paint on track of beam.	Clean off oil, grease or paint.
	Trolley not spaced for beam clearance.	Check trolley spacing. Refer to “INSTALLATION” section on page 8.
Air-powered trolley does not operate.	Pendant lever sticking.	Check lever and restore free movement.
	Emergency valve in “OFF” position.	Reset Emergency stop and push “ON” button.
	No air supply to trolley or too little CFM (cu. m/min.) or PSI (kPa/bar).	Check PSI (bar) at trolley inlet. Refer to manufacturer’s specifications.
	Control valve is sticking.	Refer to “MAINTENANCE” section on page 26.
	No oil in trolley motor or gearbox.	Check oil levels in trolley motor and gearbox and fill to required level.
	Wheels are obstructed.	Remove obstruction.
	Motor is damaged.	Repair or replace. Refer to “MAINTENANCE” section on page 26.

⚠ WARNING

- Never perform maintenance on hoist while it is supporting a load.
- Before performing maintenance, tag controls:
WARNING - DO NOT OPERATE - EQUIPMENT BEING REPAIRED.
- Only allow personnel trained in operation and service of this hoist to perform maintenance.
- After performing any maintenance on hoist dynamically test hoist to 100% of its rated capacity, in accordance with ASME B30.16 standards, before returning hoist to service. Testing to more than 100% of rated capacity may be required to comply with standards and regulations set forth in areas outside the USA.
- Shut off air system and depressurize air lines before performing any maintenance.

Proper use, inspections and maintenance increase the life and usefulness of your **Ingersoll-Rand** equipment. During assembly, lubricate gears, nuts, capscrews and all machined threads with applicable lubricants. Use of antiseize compound and/or thread lubricant on capscrew and nut threaded areas prevents corrosion and allows for easy disassembly of components.

Maintenance Intervals

The Maintenance Interval Chart below is based on intermittent operation of equipment for eight hours each day, five days per week. If equipment is in operation for more than eight hours a day or is operated in severe applications or environments, more frequent maintenance should be performed.

INTERVAL	MAINTENANCE CHECK
Start of each shift	Make a thorough visual inspection of hoist for damage. Do not operate hoist if damage is found.
	Operate in both directions. Hoist must operate smoothly without sticking, binding or abnormal noises.
	Check operation of pendant control and brake.
Semiannually	Inspect disc brake friction linings and sprag clutch assembly. Clean or replace parts as required.
Yearly	Inspect hoist gearing, shafts and bearings for damage or wear. Repair or replace as necessary.
	Check all of supporting members, including trolley if used. Repair or replace as required.

Disc Brake Adjustment

No disc brake adjustment is required. If brake fails to hold load, brake must be disassembled, inspected, repaired and tested prior to placing hoist in service. Refer to 'Power Head Disassembly' on page 30. When any part of friction disc thickness measures 0.072 in. (1.83 mm) or less, or if oil groove pattern is not clearly visible, friction discs must be replaced.

Load Chain Replacement

Load Chain Weld Placement

It is suggested that a short length of 22 mm load chain be available when replacing hoist load chain. Feeding a short length of load chain through bottom block assembly or power head assembly prior to installing new load chain may simplify installation. Weld on perpendicular load chain must always face away from sheaves. Refer to Dwg. MHP0042 on page 26.

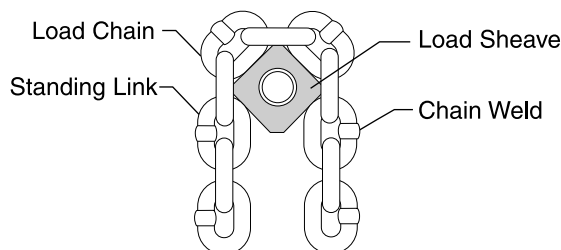

(Dwg. MHP0042)

Replacement Load Chain Link Arrangement

Correct load chain installation requires that load chain have either an even or odd number of total chain links. Refer to Dwg. MHP1990 on page 26 for illustration of how to determine chain arrangement.

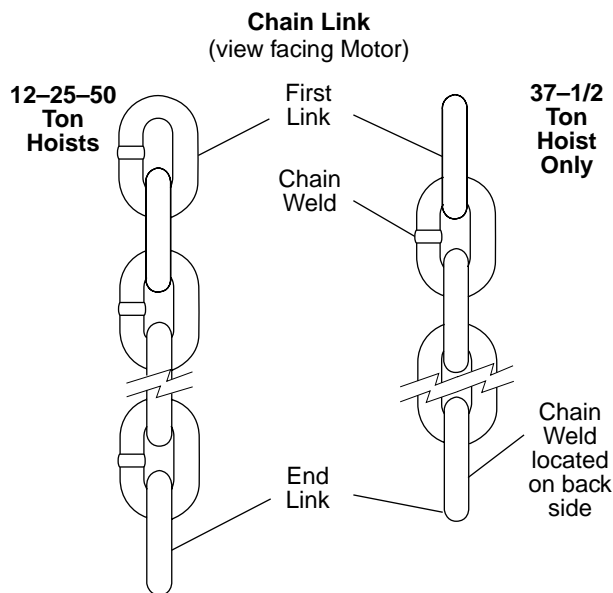

(Dwg. MHP1990)

Load Chain 'C' Link

Load chain replacement for all hoist models can be accomplished efficiently and easily by using existing load chain to install new load chain.

1. Using an abrasive wheel, cut a section from end link of existing chain to form a 'C' link. Refer to Dwg. MHP1219 on page 27.

'C' Link Dimension

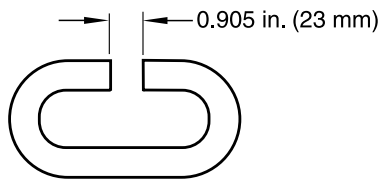

'C' Link

(Dwg. MHP1219)

⚠ CAUTION

• Do not distort link in any manner. The link must be able to pass over chain sheaves without binding.

2. Connect new chain to old chain by inserting end of new chain into 'C' link. Make certain welds and links on new chain match positioning of welds and links on chain being replaced. For model-specific information, refer to the appropriate hoist model diagram.

Twisted, Kinked or 'Capsized' Load Chain

Ensure chain is not twisted, kinked or 'capsized' during installation. Refer to Dwgs. MHP0020 on page 27 and MHP0043 on page 27.

Twisted Chain

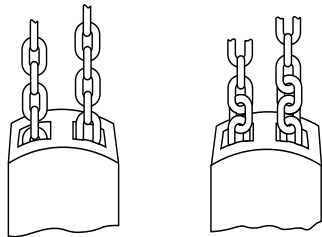

Appearance of chain that is Not Twisted

Appearance of chain that Is Twisted

(Dwg. MHP0020)

Capsized Chain

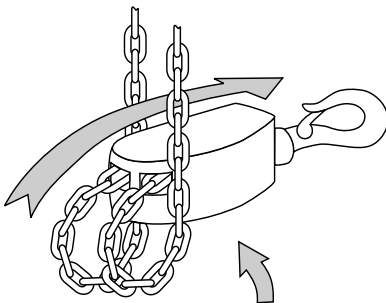

Make certain the bottom block has NOT been flipped through the chain falls

(Dwg. MHP0043)

HA2-012 Hoist

Refer to Dwg. MHP0428 on page 27.

1. The hoist should be installed and connected to air supply. Reduce hoist air pressure to 60 psi (4 bar/414 kPa).
2. Remove chain bucket, if used.
3. Remove load chain stopper (241).
4. Remove bottom block assembly (11).
5. Cut new load chain to length. Load chain must have an even number of links (first and last links must be at 90° to each other). Refer to Dwg. MHP1990 on page 26.
6. Run hoist slowly in lifting direction until load chain free end is approximately 2 ft. (0.6 m) from hoist.
7. Using a 'C' link which is the same size as load chain to old taking care that weld on perpendicular *standing* links on new load chain are facing away from hoist load sheave.
8. Run hoist slowly until new load chain has passed 2 to 3 feet (0.6 to 1 m) through hoist. Remove 'C' link and old chain.
9. Install chain stopper (241) in last link of load chain free end.
10. Install bottom block assembly (11).
11. Lubricate entire length of load chain before operating hoist. Refer to "LUBRICATION" section on page 21.

HA2-012 Chain Reeving

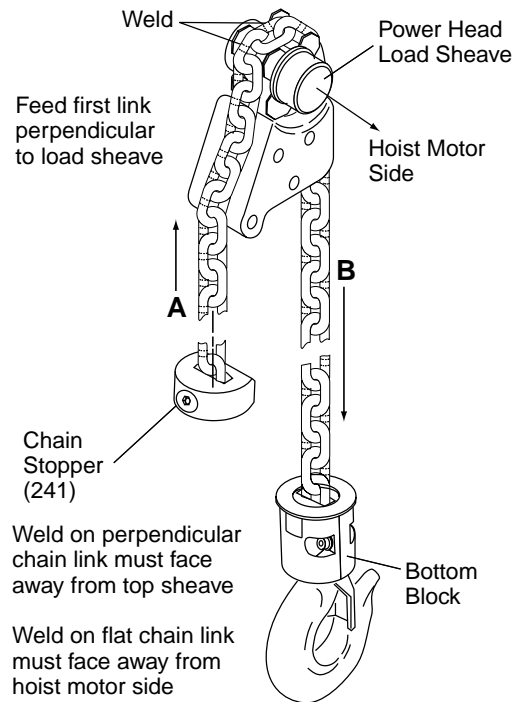

(Dwg. MHP0428)

HA2-025 Hoist

Refer to Dwgs. MHP0337 on page 28 and MHP0353 on page 40.

1. The hoist should be installed and connected to air supply. Reduce hoist air pressure to 60 psi (4 bar/414 kPa).
2. Remove chain bucket, if used.
3. Remove load chain stopper (241).
4. Run hoist slowly in lifting direction until bottom block assembly (11) is approximately 3 ft. (1 m) from hoist power head. Firmly support and secure bottom block assembly (11) in this position.

⚠ WARNING

• Do not begin chain replacement until bottom block assembly is fully secured and supported. If bottom block assembly or chain are dropped, they could cause injury or damage property.

- Cut new load chain to length. Load chain must have an even number of links (first and last links must be at 90° to each other). Refer to Dwg. MHP1990 on page 26.
- Remove pins (46) and (47) that anchor load chain to power head assembly.
- Using a 'C' link which is the same size as load chain join new load chain to free end on old chain taking care that weld on perpendicular *standing* links on new chain are facing away from hoist load sheave.
- Run hoist slowly until new load chain has passed through hoist. Continue running hoist and pull chain by hand through bottom block assembly (11). Begin feeding chain at position 'A' and work alphabetically. Remove 'C' link and old chain.
- Anchor end of load chain to power head assembly. Install chain stopper (241) in last link of load chain free end.
- Lubricate entire length of load chain before operating hoist. Refer to "LUBRICATION" section on page 21.

HA2-025 Chain Reeving

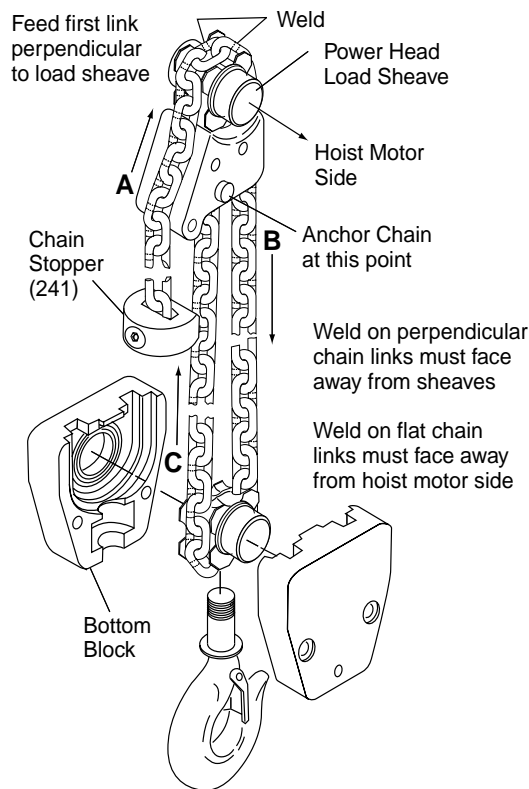

(Dwg. MHP0337)

HA2-037 Hoist

Refer to Dwg. MHP0332 on page 28 and MHP0316 on page 68.

- The hoist must be installed and connected to air supply. Reduce hoist air pressure to 60 psi (4 bar/414 kPa).
- Remove chain bucket, if used.
- Remove chain stopper (241).
- Run hoist slowly in lifting direction until bottom block assembly (11) is approximately 3 ft. (1 m) from hoist power

head. Firmly support and secure bottom block assembly (70) in this position.

⚠ WARNING

• Do not begin chain replacement until bottom block assembly is fully secured and supported. If bottom block assembly or chain are dropped, they could cause injury or damage property.

- Cut new load chain to length. Load chain must have an odd number of links (first and last links must be in same plane/parallel to each other). Refer to Dwg. MHP1990 on page 26.
- Remove capscrew (416) and cotter pin (414) that anchor load chain to bottom block assembly.
- Using a 'C' link which is same size as load chain, join new load chain to free end on old chain taking care that weld on perpendicular *standing* links on new chain are facing away from hoist load sheave.
- Run hoist slowly until new load chain has passed through hoist. Continue running hoist and pull chain by hand through bottom block assembly (11). Begin feeding chain at position 'A' and work alphabetically. Remove 'C' link and old chain.
- Attach end of load chain to bottom block assembly. Install chain stopper (241) in last link of load chain free end.
- Lubricate entire length of load chain before operating hoist. Refer to "LUBRICATION" section on page 21.

HA2-037 Chain Reeving

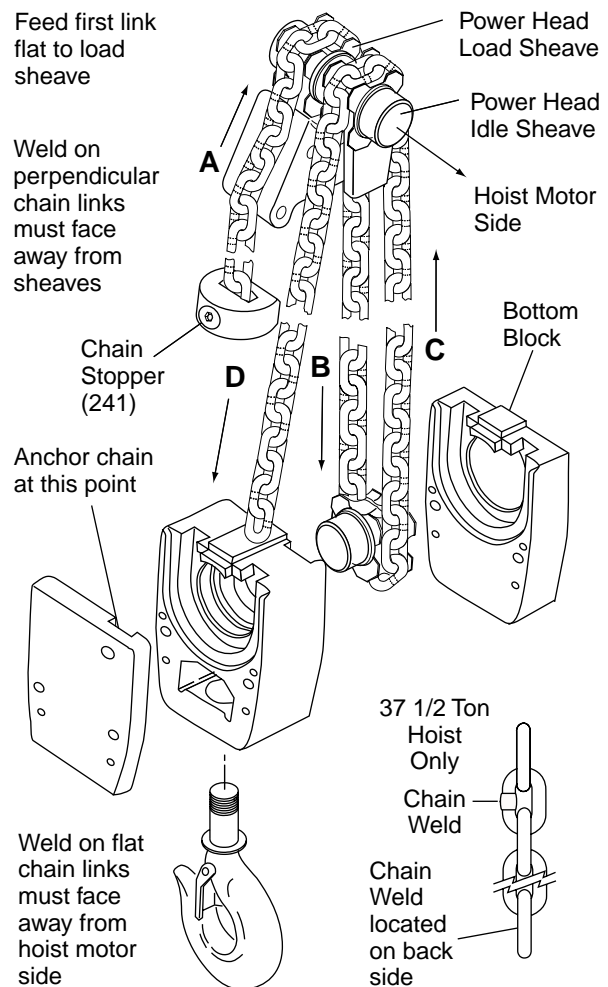

(Dwg. MHP0332)

HA2-050 Hoist

Refer to Dwg. MHP0331 on page 29 and MHP0353 on page 40.

1. The hoist must be installed and connected to air supply. Reduce hoist air pressure to 60 psi (4 bar/414 kPa).
2. Remove chain bucket, if used.
3. Remove chain stopper (241).
4. Run hoist slowly in lifting direction until bottom block assembly (11) is approximately 3 ft. (1 m) from hoist power head. Firmly support and secure bottom block assembly (11) in this position.



• Do not begin chain replacement until bottom block assembly is fully secured and supported. If bottom block assembly or chain are dropped, they could cause injury or damage property.

HA2-050 Chain Reeving

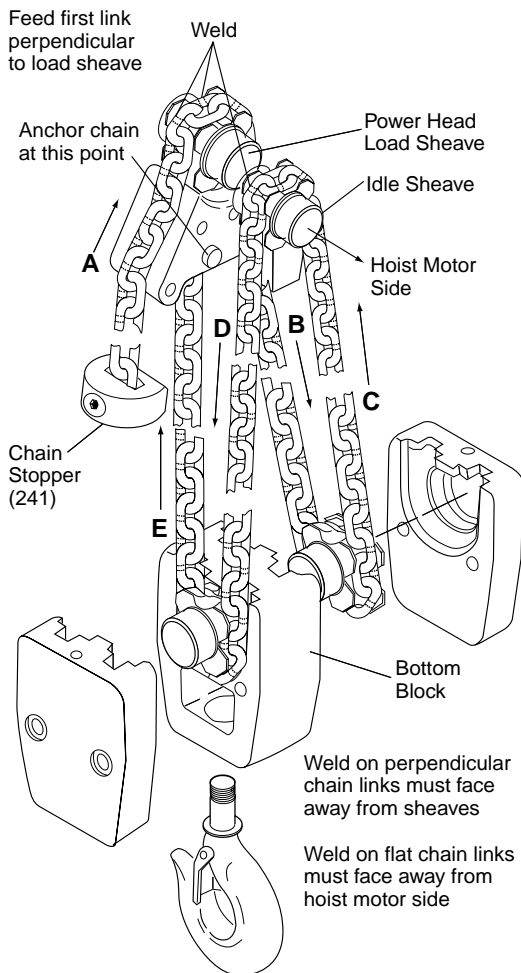

(Dwg. MHP0331)

5. Cut new load chain to length. Load chain must have an even number of links (first and last links must be at 90° to each other). Refer to Dwg. MHP1990 on page 26.
6. Remove pins (46) and (47) which anchor load chain to power head assembly.
7. Using a 'C' link which is the same size as load chain join new load chain to free end on old load chain taking care that weld on perpendicular *standing* links on new load chain are facing away from hoist load sheave.

8. Run hoist slowly until the new load chain has passed through hoist. Continue running hoist and pull chain through bottom block assembly (11). Begin feeding chain at position 'A' and work alphabetically. Remove 'C' link and old chain.
9. Anchor end of load chain to power head assembly. Install chain stopper (241) in last link of load chain free end.
10. Lubricate entire length of load chain before operating hoist. Refer to "LUBRICATION" section on page 21.

General Disassembly

The following instructions provide the necessary information to disassemble, inspect, repair, and assemble the hoist. Complete assembly drawings of the hoist components are provided in the "PARTS" section beginning on page 39.

If hoist is being completely disassembled for any reason, follow the order of the topics as they are presented. It is recommended that all maintenance work on hoist be performed on a bench in a clean dust-free work area.

In the process of disassembling hoist, observe the following:

1. Turn off air system and depressurize air lines before performing any maintenance. Disconnect hoses from hoist and trolley. Plug or cap openings to keep out dirt and contaminants.
2. Never disassemble hoist any further than is necessary to accomplish the needed repair. A good part can be damaged during the course of disassembly.
3. Never use excessive force when removing parts. Tapping gently around the perimeter of a cover or housing with a soft hammer, for example, is sufficient to break the seal.
4. Do not heat a part with a flame to free it for removal, unless the part being heated is already worn or damaged beyond repair and no additional damage will occur to other parts.
5. In general, hoist is designed to permit easy disassembly and assembly. The use of heat or excessive force should not be required.
6. Keep the work area clean to prevent dirt and other foreign matter from getting into bearings and other moving parts.
7. All seals and 'O' rings should be discarded once they have been removed. New seals and 'O' rings should be used when assembling the hoist.
8. When grasping a part in a vise, always use leather or copper covered vise jaws to protect the surface of part and help prevent distortion. This is particularly true of machined surfaces, threaded members and housings.
9. Do not remove any part which is press fit in or on a subassembly unless the removal of that part is necessary for repairs or replacement.
10. To avoid damaging bearings during hoist assembly or disassembly always tap or press on bearing inner race for shaft fit bearings or outer race for bore fit bearings.

Gearred Trolley Disassembly

Refer to Dwg. MHP0282 on page 62.

1. Remove capscrews (236), lockwashers (142) and separate trolley drive assembly from side plate (184).
2. Remove capscrews (178) and remove power head assembly.
3. Remove capscrews (157), lockwashers (158), cap (169) and bracket (175) from trolley brackets (177).
4. Remove cotter pins (173) and tap pins (174) out of suspension yokes (170). Note position of spacers (156) for reassembly.
5. Separate side plates (150) and remove suspension yokes (170).

- Remove retainer ring (155) and pull wheels (151) or (179) from side plates.
- Remove oil seal (152) and retainer ring (153) from wheels (151) or (179). Press bearing (154) out of wheels (151) or (179). Refer to Dwg. MHP0414 below.

Bearing Replacement–Trolley Wheels

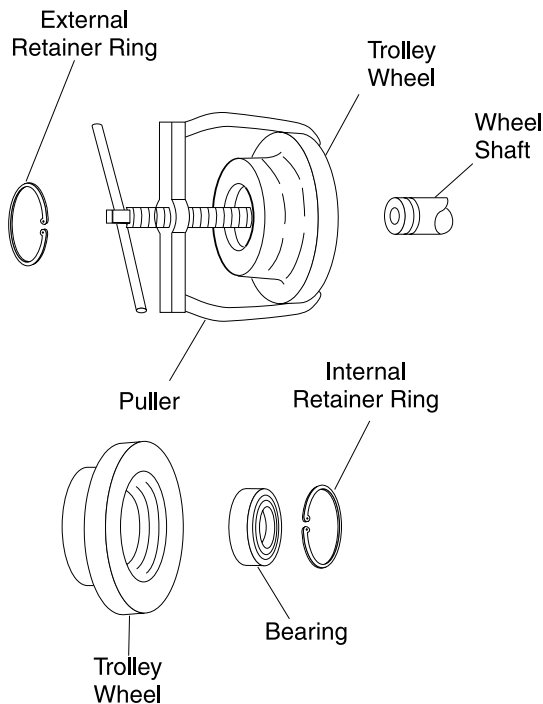

(Dwg. MHP0414)

Power Head Disassembly

Refer to Dwgs. MHP0353 on page 40 and MHP0359 on page 42.

- Disconnect all hoses from hoist motor. On trolley mounted hoists remove power head assembly from trolley. Drain oil from reducer, brake and motor assemblies. Position power head assembly vertically so brake end is up. Remove valve and manifold assembly.
- Remove capscrews (468) and lockwashers (54) and pry motor assembly (450) from adapter (2). Set motor assembly to one side for later disassembly.
- Remove capscrew (48), nut (56), washers (49), bushing (50), spacer (87) and limit arm (52).
- On trolley mounted hoists remove capscrews (81) and plate (80). On hook mounted hoists remove top hook assembly (149).
- Carefully loosen each of the eight capscrews (1) 4 or 5 turns each progressively around adapter (2) until brake spring compression is relaxed. Do not allow adapter to become cocked during removal.
- When brake spring compression is relaxed remove capscrews (1), adapter (2) and brake springs (5).
- Remove cylinder (14) and brake piston (7) as an assembly from brake housing (27).
- Tap brake piston (7) out of cylinder (14) and remove seals (6) and (8).

NOTICE

- Hoists with serial numbers lower than HL0510992 used 'O' rings on brake piston (7). Parts are not interchangeable. If brake piston requires replacement refer to 'Hoist Upgrades' on page 81 for kit.
- When any part of friction disc thickness measures 0.072 in. (1.83 mm) or less, or if oil groove pattern is not clearly visible, friction discs must be replaced.

- Remove brake hub assembly, brake discs (23) and friction discs (22).
- Remove capscrews (25) and pry brake housing (27) from frame (36).
- If brake hub must be disassembled for inspection or repair remove retainer ring (9) and washer (10) from shaft (12). Carefully tap or press bushing (18) out of back side. Take sprag clutch (19) out of brake hub (20).

NOTICE

- If sprag clutch (19) is removed from brake hub (20), use extreme care as individual sprags will fall out and may be lost.

Reposition power head assembly vertically so brake end is down.

- Remove capscrews (66) and pry complete reducer assembly from frame (45). Separate housings and ring gears only if 'O' rings are being replaced or gear teeth in ring gears are damaged.
- If housings are separated remove thrust washer (74), planetary assembly (73) and sun gear (72).
- Remove remaining planetary assemblies (64), (60) and sun gear (63).
- Remove capscrews (35) and separate frames (36), (45) and (82). Frame (82) is used in 37-1/2 and 50 ton units only.
- Remove drive sheave (40). Remove capscrews (25) and lift stripper (43) from frames.
- Remove capscrews (39) and inserts (38) from frames.
- Pull bearings (32) from drive sheave (40) if bearing or seal replacement is required.

Top Hook Disassembly

Refer to Dwgs. MHP0344, MHP0345, MHP0346 and MHP0347 on page 66.

- Remove hoist from mounting structure.
- To remove hook and plate assembly (hook cannot be removed before hook plate) remove capscrews (283) and (178) to separate hook plate assembly from power head. On HA2-012 hoists capscrew (284) must also be removed.
- To remove hook (408) from hook plate (280) drive out roll pin (406) and remove nut (405) from threaded hook end.
- Remove hook (408) and bearing (407) from hook plate (280).

Bottom Block Disassembly

HA2-012 Hoist

Refer to Dwg. MHP0314 on page 69.

- Always make sure load chain is removed before disassembly.
- Remove capscrews (402) and nuts (403) securing hook blocks (400). Pry hook blocks (400) apart.
- Drive out pin (406) and remove nut (405) on threaded hook section. Remove bearing (407).
- Remove pin (414).

HA2-025 Hoist

Refer to Dwg. MHP0315 on page 69.

1. Always make sure load chain is removed before disassembly.
2. Remove capscrews (402) and nuts (403) securing hook blocks (400). Partially drive out dowel pins (412) and pry hook blocks (400) apart.
3. Drive out pin (406) and remove nut (405) from threaded hook section. Remove bearing (407).
4. Remove bearings (32), sheave (41) and quad seals (34) from hook blocks (400).

HA2-037 Hoist

Refer to Dwg. MHP0316 on page 68.

1. Always make sure load chain is removed before disassembly.
2. Remove capscrews (402) securing side block (400) to hook center block (413) and pry hook block (400) from hook center block (413). (Engagement of dowel pins (412) may make removal difficult).
3. If hook (408) is being removed it will be necessary to remove side plate (415). Remove capscrews (402) and pry off side plate (415). (Engagement of dowel pins (412) may make removal difficult.)
4. Drive out pin (406) and remove nut (405) from threaded hook section. Pull hook (408) from hook center block (413) and remove bearing (407).
5. Remove bearings (32), sheave (41) and 'O' rings (410) from hook block (400) and hook center block (413).

HA2-050 Hoist

Refer to Dwg. MHP0317 on page 68.

1. Always make sure load chain is removed before disassembly.
2. Remove capscrews (402) securing hook blocks (400) to hook center block (413) and pry hook blocks (400) from both sides of hook center block (413). (Engagement of dowel pins (412) may make removal difficult).
3. Drive out pin (406) and remove nut (405) from threaded hook section. Pull hook (408) from hook center block (413) and remove bearing (407).
4. Remove bearings (32), sheaves (41) and quad seals (34) from hook blocks (400) and hook center block (413).

Motor Disassembly

Refer to Dwg. MHP0359 on page 42 and MHP0382 on page 44.

1. Remove plug (486) and drain oil into a suitable container.
2. Remove capscrews (500), lockwashers (54) and valve cap (502) from manifold (504). Pull out rotary valve (467) and rotary valve bushing (466). Remove valve and manifold assembly.
3. Support the weight of motor assembly (450). Remove capscrews (468) and lockwashers (54), and pull from power head assembly.



• **Air Motor weighs approximately 80 lbs (37 kgs). Adequately support air motor before removing mounting capscrews.**

4. Remove the capscrews (55), copper washers (452) and cylinders (453) from the motor housing (463).
5. Rotate the crankshaft assembly (473) to bring each wrist pin assembly (457) above the motor housing (463), then push out the wrist pin assembly (457) and remove piston assembly (455). Plugs (456) pressed into ends of wrist pins (457) should not be removed. To avoid breakage use extreme care when removing compression rings (454).

6. Pull the crankshaft assembly (473) with attached connecting rods (459) out of the motor housing (463) by shifting the connecting rods (459) to clear the cylinder holes. The connecting rods (459) are joined through a common journal on the crankshaft and are held in place by connecting rod rings (474) on each side of the main rib.
7. To remove the connecting rods (459) from the crankshaft assembly (473).
8. Loosen capscrew (166) and drive out the taper pin (479) securing the counterbalance section to the crankshaft section.
9. Remove counterbalance section, then pull off connecting rod rings (474), connecting rods (459), bushing (476) and sleeve (475).

Trolley Drive Disassembly

Refer to Dwg. MHP0306 on page 64.

1. Remove capscrews (236) and lockwashers (70) then pull trolley drive assembly from trolley side plate (184).
2. Remove retainer ring (180) and drive gear (182) from shaft (208).
3. Remove capscrews (234) and lockwashers (233) from reducer adapter (232). Carefully pry reducer adapter (232) from housing (212).
4. Remove spacer (230) and sleeve (229) from shaft (208). Remove oil seal (228) from reducer adapter (232). Pull shaft (208) with worm gear (226) and bearing cones (205) from housing (212).
5. Remove motor adapter (220) from housing (212) with bearing cup (218).
6. Remove four screws (200), cover (225) and cover shims.
7. Pull worm (214) from housing (212).
8. Carefully pull bearing cones (217) from worm (214).
9. Remove oil seal (219) from motor adapter (220).
10. Pull bearing cup (218) out of cover (225).
11. Remove screws (200), cover (202) and gaskets (203) from housing (212).
12. Remove worm gear (226) from shaft (208).
13. Remove bearing cone (205) and spacer (206).

Trolley Drive Piston Motor Disassembly

Refer to Dwg. MHP0381 on page 58 and Dwg. MHP0415 on page 54.

NOTICE

- **Follow disassembly instructions 1 through 12 and 17 through 19 for hoist with serial numbers below HL-19300.**
- **Follow disassembly instruction 1 through 8 and 13 through 19 for hoist with serial numbers above HL019300.**

1. Remove motor assembly (329) from trolley drive assembly and move to a clean work surface.
2. Drain oil from motor housing (369) into a suitable container by removing pipe plug (379).
3. Disassembly and reassembly will be simplified if crankshaft (354) is held vertically in a soft-jawed vise or supported vertically on suitable packing, to raise crankshaft clear of work surface.
4. Remove capscrews (334) and valve assembly (625).
5. Remove capscrews (340) and cover (339).
6. Remove capscrews (334) and rotary valve housing (332).
7. Support rotary valve housing evenly on flange face. Tap rotary valve (337) out of rotary valve housing (332) from inside outwards. Normal clearance between rotary valve

- (337) and rotary valve housing (332) is 0.002 to 0.003 in. (0.05 to 0.075 mm). Replace parts if wear is excessive.
8. Remove retaining ring (335) and bearing (336) from rotary valve housing (332).
 9. Remove capscrews (334) and cylinders (375) from motor housing (369). When all four piston assemblies (373) have been removed, remove bearing (352), ring (351) and spacer (353).
 10. Remove setscrew (346) and balance weight (345). Remove spacer washers (347) and note thickness for subsequent reassembly.
 11. Remove ring (351) now exposed.
 12. Remove capscrews (334) and cylinders (375) from motor housing (369). Slide connecting rod (349) along the bearing (352) towards open end of motor housing (369), until connecting rod slipper end is clear of the ring (351). Push out the complete piston assembly, from inside motor housing (369).
 13. Remove capscrews (334) and cylinders (375) from motor housing (369).
 14. Remove washers (380) and note thickness for subsequent reassembly.
 15. Remove pins (384) and connecting rod (382) from connecting rod (381). Slide connecting rod (381) from along with bearing (383) through open end of motor housing (369).
 16. remove bearing (383).
 17. Remove retainer ring (366) and spacer (367) and shims (365).
 18. Press out crankshaft (354), aligning oil thrower with opening in motor housing (369).
 19. Clean off jointing compound from rotary valve housing bore (332) and outside of valve bush (136) with “Hermetite” 1325B solvent or similar.

Trolley Drive Vane Motor Disassembly

Refer to Dwg. MHP0379 on page 56.

1. Remove capscrews (262) from cover (260) and pull vane motor assembly from trolley drive assembly.
2. Remove capscrews (273) and (274). Pull pilot control valve (270) from valve manifold (267).

NOTICE

• **Pilot control valve (270) repair should be limited to removal of end caps, bushings and plunger to replace the ‘O’ rings. Refer to Dwg. MHP0407 on page 55.**

3. Remove capscrews (268) and valve manifold (267) from cylinder (256).
4. Remove capscrews (265) and pry cover (260) from cylinder (256).
5. Remove cover (253) from cylinder (256).
6. Slide shaft and rotor (259) from cylinder (256). Be careful not to drop or damage vanes (258) during this operation.
7. Remove capscrews (264) and cap (263) from cover (260).
8. Tap bearings (251) from motor adapter (220) and cover (260).

Cleaning, Inspection and Repair

Use the following procedures to clean, inspect, and repair the components of the hoist.

Cleaning

Clean all hoist component parts in solvent (except for the friction discs). The use of a stiff bristle brush will facilitate the removal of

accumulated dirt and sediments on the gears and frames. If bushings have been removed it may be necessary to carefully scrape old Loctite® from the bearing bores. Dry each part using low pressure, filtered compressed air.

CAUTION

- **Bearings that are loose, worn or rotate in the housing must be replaced. Failure to observe this precaution will result in additional component damage.**
- **Do not use trichloroethylene to clean parts.**
- **If trolley suspension yoke bushings (176) are loose or worn they must be replaced. Failure to observe this precaution will result in additional component damage.**

Inspection

All disassembled parts should be inspected to determine their fitness for continued use. Pay particular attention to the following:

1. Inspect all gears for worn, cracked, or broken teeth.
2. Inspect all bushings for wear, scoring, or galling.
3. Inspect shafts for ridges caused by wear. If ridges caused by wear are apparent on shafts, replace the shaft.
4. Inspect all threaded items and replace those having damaged threads.
5. Measure the thickness of the friction discs (22). If the friction discs are less than 0.072 in. (1.83 mm) or if oil groove pattern is not clearly visible replace the friction discs (22).
6. Check mufflers (107), (266) and (566) for damage or excessive dirt.
7. Inspect yoke bushings (176) for wear, scoring, or galling. If wear exceeds discard dimensions in Table 9 replace bushings.

Table 11 — Bushing (176) Inspection Specifications

Hoist Model	Item No.	Bushing Part No.	Original Bore Size		Discard Bore Size	
			in.	mm	in.	mm
HA2-012	176	21833	3.253	82.6	3.315	84.2
HA2-025		16187	3.437	87.3	3.500	89
HA2-037		16190	4.500	114.3	4.562	116
HA2-050						

8. Check bearings for ease of rotation and wear. Replace bearings if rotation is rough or bearings are excessively worn.
9. Check the sprag clutch assembly for wear, flat spots on the sprags or damage. If any of these conditions exist, replace parts.
10. Inspect sprag clutch wear area on brake hub (20) and on brake shaft (12) for ridges or galling. If either condition exists replace parts.

NOTICE

• **If brake hub (20), sprag clutch (19) or brake shaft (12) require replacement, it is recommended that all three parts be replaced at the same time.**

Repair

Actual repairs are limited to the removal of small burrs and other minor surface imperfections from gears and shafts. Use a fine stone or emery cloth for this work.

1. Worn or damaged parts must be replaced. Refer to the applicable parts listing for specific replacement parts information.
2. Inspect all remaining parts for evidence of damage. Replace or repair any part which is in questionable condition. The cost of the part is often minor in comparison with the cost of redoing the job.
3. Smooth out all nicks, burrs, or galled spots on shafts, bores, pins, or bushings.
4. Examine all gear teeth carefully, and remove nicks or burrs.
5. Polish the edges of all shaft shoulders to remove small nicks which may have been caused during handling.
6. Remove all nicks and burrs caused by lockwashers.
7. Replace all seals, 'O' rings and gaskets.

Assembly Instructions

Trolley Assembly

Refer to Dwg. MHP0282 on page 62.

1. Press bearings (154) into wheels (151) or (179). Install retainer rings (153) and oil seals (152) in wheels (151) or (179).
2. Install wheels (151) or (179) on side plates. Install retainer rings (155).
3. Coat suspension yoke ends with grease then install side plates (150) or (184) on suspension yokes (170). Install spacers (156) in same location as noted during disassembly.
4. Install pins (174). Secure pins (174) with cotter pins (173) and bend ends apart.
5. Install brackets (177) in suspension yokes (170). Install cap (169) and bracket (175) with capscrews (157) and lockwashers (158).
6. Install power head assembly between brackets (177). Install capscrews (178), with a small amount of Loctite® 242 on the threads and torque to 525 ft.-lb (712 Nm)
7. Install trolley drive assembly on side plate (184).

Power Head Assembly

Refer to Dwg. MHP0353 on page 40.

1. Install insert (38) with screws (39) using Loctite® 242 in frame (36) (motor side). Lubricate and install 'O' rings (33) in large bore of frames (36) and (45).
2. Install seals (34) in groove on both sides of sheave(s) (40). Press a bearing (32) onto both sides of load sheave(s) (40).
3. Install assembled load sheave (40) into frame (45) so splined end enters first. Be careful not to damage 'O' ring (33) in bore of frame (45).
4. Install chain stripper (43) on frame (45) and secure with capscrews (25). Apply a small amount of Loctite® 242 on the threads and torque to 110 ft.-lb (149 Nm).
5. Tap dowel pins (37) into frame (45). Install a short length of 22 mm starter chain around load sheave.
6. Install insert (38) in frame (45) with screws (39) using Loctite® 242.
7. Install frame (36) to frame (45) so it positions over the sheave (40) and bearing (32). Clamp frames (36) and (45) together with capscrews (35). Use Loctite® 242. Torque capscrews to 400 ft.-lb (542 m). On 37-1/2 and 50 ton units also install frame (82) and idle sheave (41).
8. Install spacer (44) over sheave spline.

To assist parts assembly it is recommended that the power head be positioned in a vertical position with the gear end up.

9. Pre-assemble gear reducer outer housings. Install two capscrews 180° apart in cover (78) and place cover on work bench. Lubricate and install 'O' rings (68) on both sides of ring gear (77) then place on cover (78) so capscrews holes are aligned.
10. Tap dowels (76) partially into spacer (75) then install spacer (75) on ring gear (77). Lubricate and install 'O' rings (68) on both sides of ring gear (69). Install ring gear on spacer (75).
11. Install input housing (65) and remaining capscrews (79). Apply a small amount of Loctite® 242 on capscrews (79) and torque to 32 lb. ft. (44 Nm). Avoid damaging 'O' rings during assembly. Tap dowel pins (83) into cover (78) until flush.
12. Install large planetary assembly (60) on spline of sheave (40). Apply a small amount of grease to thrust washer (62) and press into sun gear (63). Install sun gear (63).
13. Install planetary assembly (64) so it engages with sun gear (63). Apply a small amount of grease to thrust washer (62) and press into sun gear (72) and install sun gear (72).
14. Install planetary assembly (73) so it engages with sun gear (72).
15. Install shaft (30) through center of planetary assemblies so gear end meshes with planet gears in planetary assembly (73).
16. Lubricate and install 'O' rings (57) on ring gear (58).
17. Install ring gear on frame (45). Place thrust washer (74) on the end of shaft (30).
18. Install pre-assembled outer housings over planetary assemblies so fitting (71) and breather (421) are at the top. (The breather hole can be determined as being the hole which will be directly in line with a dowel pin when capscrew holes are aligned.)
19. Drive dowel pins (59) through flange into ring gear (58) and frame (45).
20. Install capscrews (66) with Loctite® 242 and lockwashers (142) to secure reducer housing to frame (45). Torque capscrews (66) to 85 ft.-lb (115 Nm).

To assist parts assembly it is recommended that the power head be repositioned in a vertical position with the motor end up.

21. Lubricate and install 'O' ring (4) in shoulder recess of brake housing (27). Install brake housing (27) on frame (36). Secure with capscrews (25) and torque to 85 ft.-lb (115 Nm). Position brake housing (27) so the two valve mounting pads are located at the bottom.
22. Install pipe plugs (26) and (28) in brake housing (27).
23. Press one bushing (18) into brake hub (20). Install shaft (12) into assembly. Slide sprag clutch (19) onto shaft (12) and into brake hub (20). Press in second bushing (18). Ensure sprags are assembled all in the same direction and springs are not twisted or out of location. Sprag clutch must be installed so that the end with the stamped arrow is nearest the motor adapter. Check that shaft rotates freely counterclockwise when looking at the non splined end of brake hub (20) and locks up instantly in the clockwise direction. Check rotation of shaft in free sprag clutch direction is smooth. If tightness or rough rotation exists disassemble and inspect.
24. Install washer (10) and retainer ring (9) on shaft (12). Press bearing (24) onto shaft (12).
25. Starting with a friction disc (22) and alternating with brake discs (23), install friction discs (22) and brake discs (23) in brake housing (27).
26. Install motor coupling (29) on the end of the shaft (12) and install assembled shaft and brake hub assembly through brake. Remove pipe plug (26) in brake housing (27) to check that brake hub is properly engaged with each friction disc (22). Use of artificial light will aid inspection. Line up plates

- and tap gently on shaft if bearing (24) is tight in brake housing (27).
- On older hoists install screws (13), seal washers (16) and nuts (17) in two locations in the brake cylinder (14). Check that screws (13) are slightly below the cylinder surface on the brake piston (7) side. Screws should extend 1/2 in. (12.7 mm) from the face of the brake cylinder (14). Adjust both screws evenly. Refer to Dwg. MHP0397 below. Newer hoists are not equipped with and do not require screws (13).

⚠ WARNING

• Adjustment of screws (13) may disengage brake. Load can drop without warning. Refer to Dwg. MHP0397 on page 34.

Older style hoists only

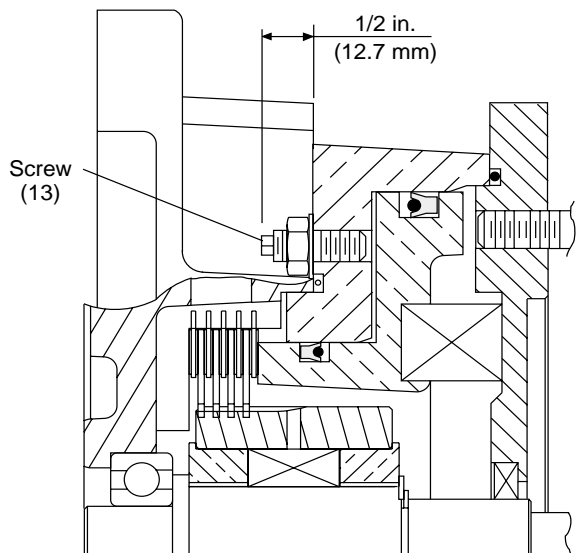

(Dwg. MHP0397)

- Lubricate and install seals (6) and (8) on brake piston (7). Seal lips must face each other. Refer to Dwg. MHP0139. Install 'O' ring (15) in recessed groove in brake cylinder (14).

NOTICE

• Hoists with serial numbers lower than HL0510992 used 'O' rings on brake piston (7). Parts are not interchangeable. If brake piston requires replacement refer to parts section for upgrade kit.

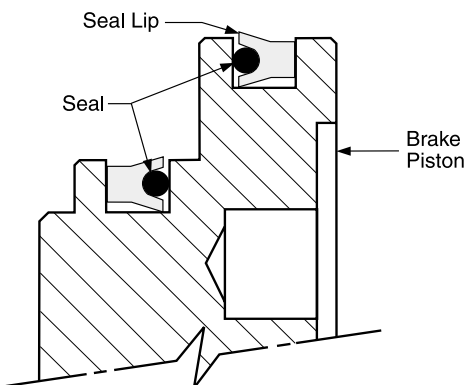

(Dwg. MHP0139)

- Apply a thin film of grease to bore of brake cylinder (14) and install brake piston (7).

- Install assembled brake piston (7) on brake housing (27) so brake port hole is positioned on the right hand side and machined pad is at the bottom.
- Set brake springs (5) into holes provided in the brake piston (7).
- Install oil seal (3) in motor adapter (2) so lip of seal (3) is toward the brake. Lubricate and install 'O' ring (4) in recessed groove in motor adapter (2).
- Install motor adapter (2) on brake cylinder (14) so the threaded hole, which is located dead center between the counterbored mounting bolt holes, is located at the bottom (6 o'clock position.)
- Secure motor adapter (2) with capscrews (1) and torque to 33 ft.-lb (45 Nm). Pull motor adapter down evenly to compress the brake springs (5). Tighten capscrews 4 to 5 turns each progressively round the adapter (2). Do not allow motor adapter (2) to become cocked.
- Install gasket (470) on motor adapter (2). Install motor assembly (450) so spline on shaft (12) engages motor. Position motor so drain plug (486) is located at the bottom. Secure with capscrews (468), lockwashers (54). Torque capscrews (468) to 36 ft.-lb (49 Nm).
- On trolley mounted hoists a cover plate is used instead of the top hook assembly. Install plate (80) with gasket sealant Loctite® 515 and capscrews (81).
- Install bushings (50) for limit paddle (52) in frames (36) and (45). Tap bushings (50) in until flush.
- Install limit paddle (52) with capscrew (48), bushing (50), spacer (87), washers (49) and nut (56).

Installing Valve Assembly

Refer to Dwg. MHP0382 on page 44.

- Pre-assemble valve and manifold assembly and install on the underside of brake housing (27) with capscrews (505) and washers (309). Capscrews must be finger-tight only.
- Ensure rotary bushing (466) is installed in manifold (504) and slides freely in the bore. Maximum allowable clearance of rotary valve is 0.010 in. (0.254 mm). Install valve cap (502) in manifold (504).
- Install capscrews (500) and washers (501) that attach manifold (504) to motor assembly (450). Torque manifold capscrews to 29 ft.-lb (39 Nm) before finally tightening valve to brake capscrews.

Power Head Piston Motor Assembly

Refer to Dwg. MHP0359 on page 42.

- Press bearing (465) onto crankshaft counterbalance. Place the connecting rods (459) on the bushing (476) and hold them in place with the two connecting rod rings (474). Install connecting rod rings (474) so the chamfered side is next to the connecting rod (459).
- Place the sleeve (475) on the crankshaft (473), then install the connecting rod (459) assembly on the crankshaft (473).
- Secure the crankshaft counterbalance to the crankshaft with taper pin (479) and tighten capscrew (166).
- Align bearing (465) in the bore of the motor housing (463) and tap crankshaft assembly in place until each connecting rod (459) end aligns with a cylinder hole.
- Check the fit of each compression (454) and oil ring (458) by placing one ring at a time in the cylinder (453), making sure it is not canted or tilted in relation to the cylinder wall. With a feeler gauge, measure the ring gap. Ring gap should be 0.003 to 0.004 in. (0.75 to 0.1 mm).
- Make sure that compression rings (454), oil rings (458), and pistons (455) are perfectly clean. Carefully place oil rings

(458) and compression rings (454) in their respective grooves on the pistons (455). The plain compression ring (454) must be placed nearest the head of the piston (455). The oil ring (458) with several oil channels must be placed nearest the skirt of the piston (455).

⚠ CAUTION

- Do not interchange the compression and oil rings.

7. Compression and oil ring joints (gaps) should be staggered and positioned so that joints (gaps) do not coincide with wrist pin (457) openings. Refer to Dwg. MHP0224 on page 35.

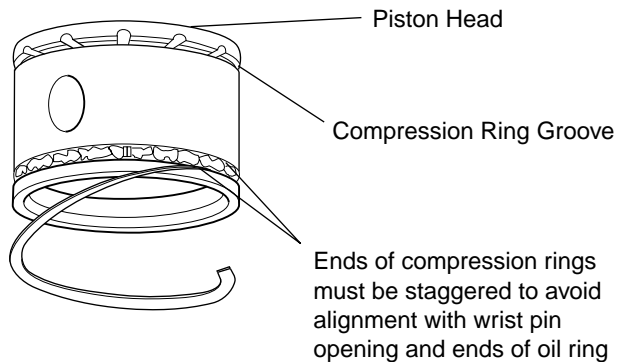

Wrist pin opening

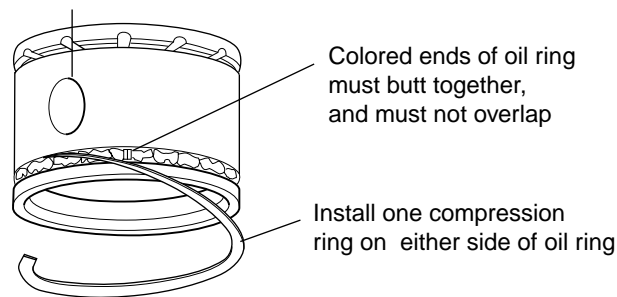

(Dwg. MHP0224)

8. Rotate the crankshaft so each connecting rod (459) in succession will project enough beyond the motor housing (463) to permit inserting the wrist pin (457) through the piston (455) and connecting rod (459).
9. After each piston (455) is assembled to its connecting rod (459), install a gasket (460) and cylinder (453).
10. Slide each cylinder (453) over the piston (455), guiding it carefully over the compression and oil rings. Note that the cylinder has four tapered ears around the skirt of the piston which serve as ring compressors to aid in installation. The cylinder should fit into place by tapping lightly. If force is required, there may be an alignment problem which must be corrected before continuing.
11. Secure cylinders (453) to the motor housing (463) with capscrews (55) and lockwashers (452) and tighten uniformly.

Trolley Drive Assembly

Refer to Dwg. MHP0306 on page 64.

1. Press or tap bearing cup (218) into housing (212) on cover (225) side.
2. Place gaskets (222, 223 and 224) on shoulder of cover (225).
3. Install cover (225) and gaskets on housing (212). Secure with four countersunk screws (200).
4. Press bearing cones (217) onto worm (214). Ensure bearings are fully seated against worm shoulder. Install worm and

- bearings in housing (212). Tap or press second bearing cup (218) into housing bore.
5. Tap or press bearing cup (204) into cover (202). Place gaskets (203) on shoulder of cover (202).
 6. Install cover (202) and gaskets on housing (212). Secure with six screws (200).

NOTICE

- Rotate cover (202) so oil level hole is just below the 3 o'clock position before installing.

7. Install keys (207) in shaft (208) and press worm gear (226) onto shaft making sure it aligns with and fits over the keys (207).
8. Install spacers (206) and (227) on shaft. Press bearing cones (205) on shaft (208) until they contact the spacers.
9. Install shaft and worm gear assembly in gear housing (212) so worm gear teeth mesh with worm.
10. Tap or press bearing cup (204) into reducer adapter (232).
11. Install reducer adapter (232) and gaskets (203) on housing (212). Secure with capscrews (234) and lockwashers (233). Check to see if shaft (208) turns freely without binding or moving from side to side.

NOTICE

- Adjust gaskets (203) to provide zero side to side motion of the worm gear assembly.

12. Install oil seal (219) in motor adapter (220) so oil seal lip faces into the housing.
13. Install oil seal (228) in reducer adapter (232) so lip faces into the housing.
14. Install motor adapter (220) on housing (212) and secure with capscrews (200) (piston motor) or capscrews (234) (vane motor).
15. Install spacer (230) on shaft (208). Take care not to damage the lip of oil seal (228).
16. Install key (183) in shaft (208). Slide drive gear (182) onto shaft (208) so it aligns with and fits over key (183).

NOTICE

- On 12 and 25 ton hoists, drive gear (182) is positioned with its recessed surface toward the reducer adapter (232). On 37.5 and 50 ton hoists, the drive gear's flat surface is positioned toward the reducer adapter. Refer to Dwg. MHP1389 on page 36.

17. Install retainer ring (180).

NOTICE

- The first bearing cup (218) must be flush against cover (225) for accurate backlash reading.

18. Rotate worm to check for tight spots and to see if backlash is between 0.004 to 0.008 in. (0.10 to 0.20 mm). Adjust shims (222, 223 or 224) until correct backlash is achieved.

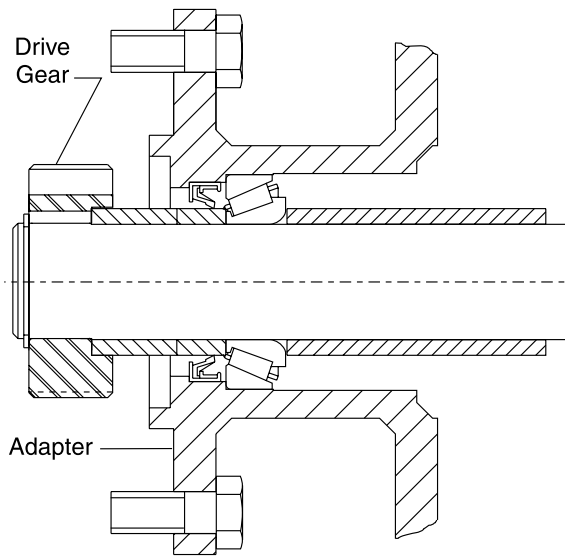

HA2-012 and HA2-025 Hoists
Install Drive Gear with recess towards Adapter

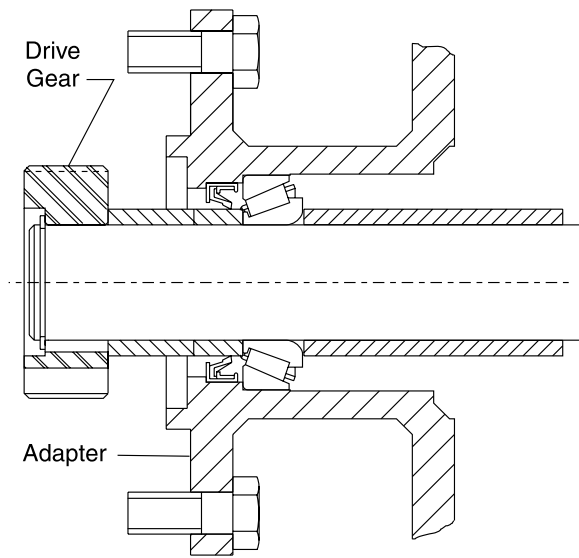

HA2-037 and HA2-050 Hoist
Install Drive Gear with recess facing away from Adapter
(Dwg. MHP1389)

Trolley Drive Piston Motor Assembly

Refer to Dwg. MHP0381 on page 58.

1. Install oil seal (358) and bearings (356) on crankshaft (354). Lip of oil seal (358) must face into motor housing (369). Tap assembled parts into position in flange plate (363).
2. Install shims (365), spacer (367) and retainer ring (366) on the end of crankshaft (354).
3. Lubricate and install 'O' ring (368) on flange plate (363). Align oil-thrower on crankshaft (354) with opening in motor housing (369) and assemble flange plate to motor housing (369) with capscrews (364).
4. Clamp the crankshaft vertically in a soft-jawed vice, shaft down.
5. Install spacer (353) so radius on inside bore of spacer is toward the crank pin shoulder.
6. Install ring (351) and bearing (352). Radius on inside bore of ring (351) must face outward.

7. Assemble the connecting rods (381 and 382) to the pistons (373). Ensure retainer rings (378) are fully seated in the grooves on wrist pins (377). Install the oil rings (370) and compression rings (372) on the pistons (373). Check gap on rings is 0.003 to 0.004 ins. (0.076 to 0.1 mm). Note: The upper compression ring (372) is plain and the lower oil ring (370) acts as an oil control.
8. Carefully install the cylinders (375) on pistons. Do not use force during this procedure and avoid damaging oil rings (370) and compression rings (372).
9. Install a gasket (374) on each cylinder. Insert the piston assemblies into the motor housing (369) bores, with the connecting rod (349) positioned correctly to seat on the needle bearing (352). When the slipper end is seated on the bearing (352), slide the connecting rod (349) inward to enter the ring (351). Install capscrews (334) so they are finger tight. When all cylinders have been installed tighten capscrews (334) evenly.
10. Install second ring (351) with the radius of the bore innermost. Install spacer (347). Rotate crankshaft 360° to ensure parts are correctly fitted.
11. Install rotary valve (337) in rotary valve housing (332). Press bearings (336) and (338) into rotary valve housing (332). Install retainer ring (335).
12. Install balance weight (345). Secure balance weight with setscrew (346).
13. Rotate the crankshaft (354) until the balance weight is at the bottom dead center position, rotate the rotary valve (337) until the balance weight is at the bottom position.

NOTICE

• Follow assembly instruction 1 through 12 and 17 through 19 for hoist with serial numbers below HL019300.

14. Install gasket (331) on rotary valve housing then assembly to motor housing and secure with capscrews (334). Rotate the output shaft in both directions and viewing the rotary valve (337) through the exhaust cover (339) opening ensure that the valve is correctly following the output shaft direction. This checks that both crank and valve slot are correctly engaged.
15. Install cover (339) and secure with capscrews (340).

Trolley Drive Vane Motor Assembly

Refer to Dwg. MHP0379 on page 56.

1. Install seal (252) in cover (253) so seal (252) is flush with cover face. Seal lip must face towards motor.
2. Install seal (254) in cover (253) so seal lip faces towards the motor.
3. Install bearings (251) in covers (253) and (260) using a small amount of Loctite® 609 on the outside bearing diameter. Pack grease between seal (252) and bearing (251) in cover (253) filling the cavity.
4. Install cap (263) on cover (260) with capscrews (264).
5. Apply gasket sealant to the motor cylinder (256) surface for cover (253). Use a minimal amount but enough to create a total seal. Install cover (253) to motor cylinder (256).
6. Install dowels (255) to align cover (253) with motor cylinder (256).

NOTICE

• Replacement rotors and cylinders must be supplied as matched sets in order to maintain the proper end running clearance of 0.002 to 0.004 in. (0.05 to 0.1 mm).

7. Apply a film of ISO VG 32 (10W) oil to the cylinder wall. Install shaft and rotor (259) in cylinder (256). Place one vane (258) in each rotor slot so that the long straight vane edge is towards the cylinder wall.
8. Apply gasket sealant to the motor cylinder (256) surface for cover (260). Use a minimal amount but enough to create a total seal. Install motor cover (260) to motor cylinder (256). Align cover with dowel pin (255) holes and carefully tap cover (260) into position until flush with the cylinder (256).
9. Install dowel pins (255) in cover (260) and cylinder (256). The relationship of the motor end covers (253) and (260) with motor cylinder (256) is very critical. In order to provide proper running clearance for the rotor, the rotor has to run exactly parallel with the cylinder (256) and perpendicular to the covers. Dowel pins (255) are used to locate these parts within 0.007 in. (0.18 mm) of correct alignment.
10. Install capscrews (265). The correct alignment is established by snugging down the capscrews (265) which retain the covers to the cylinder and checking the motor for free turning. If any drag is noted, tap around the edges of the motor covers until the shaft turns freely. Tighten capscrews to 30 in-lbs. (3.3 Nm).
11. Tap shaft key (257) into the keyway on shaft and rotor (259).
12. Install valve manifold (267) on cylinder (256) with capscrews (268).
13. Lubricate and install 'O' rings (269) in recesses in pilot control valve (270). Install pilot control valve (270) on valve manifold (267) secure with capscrews (273) and (274).
14. Install mufflers (266) in valve manifold (267).

Top Hook Assembly

Refer to Dwg. MHP0344, MHP0345, MHP0346 and MHP0347 on page 66.

1. Install hook (408) and bearing (407) in hook plate (280).
2. Install nut (405) on threaded hook end until snug. Back nut (405) off until first dowel pin (406) hole is lined up. Install pin (406). Do not attempt to drive dowel pin (406) into nut until holes are aligned or threads on hook (408) will be damaged.
3. Install hook plate assembly on power head with capscrews (178) or (283). On HA2-012 hoists also install cap screw (178). Torque to 115 ft.-lb (156 Nm).
4. Install hoist on mounting structure.

Bottom Block Assembly

HA2-012 Hoist

Refer to Dwg. MHP0314 on page 69.

1. Pack bearing (407) with grease and install bearing (407) on hook (408). Screw nut (405) onto threaded shank of hook (408).
2. Place hook with bearing and nut in one half of hook block (400) and tighten nut until parts clamp hook block. Back nut off until first dowel pin (406) hole is lined up. Install pin (406). Do not attempt to drive dowel pin (406) into nut until holes are aligned or threads on hook (408) will be damaged.
3. Install pin (414).
4. Pack cavities in hook blocks (400) with grease and place hook blocks (400) together. Apply a small amount of Loctite® 242 to capscrews threads and install capscrews (402) and nuts (403) to clamp parts. Torque capscrews to 205 lb-ft. (278 Nm). Check that hook swivels freely.
5. Install grease fitting (172) and fill block with grease. Refer to "LUBRICATION" section on page 21.

On 25, 37-1/2 and 50 ton hoists it is suggested that a short length of 22 mm chain be available when assembling the bottom block assembly. The chain should be installed around the sheave prior to final assembly of the block sections. If this procedure is followed it will simplify the installation of the load chain later.

HA2-025 Hoist

Refer to Dwg. MHP0315 on page 69.

1. Pack bearing (407) with grease and install bearing (407) on hook (408). Screw nut (405) onto threaded shank of hook (408).
2. Place hook with bearing and nut in one half of hook block (400) and tighten nut until parts clamp hook block. Back nut off until first dowel pin (406) hole is lined up. Install pin (406). Do not attempt to drive dowel pin (406) into nut until holes are aligned or threads on hook (408) will be damaged.
3. Lubricate and install quad seals (34) on sheave (41) in grooves provided. Using a press against the inner race of bearing (32) press bearings (32) onto sheave (41). Repeat the process for the opposite side.
4. Install the assembled sheave in the bottom block. Pack cavities in hook blocks (400) with grease and place hook blocks together.
5. Check dowel holes are lined up. Tap dowels (412) into position. Secure hook blocks (400) with capscrews (402) and nuts (403) using Loctite® 242. Torque capscrews (402) to 310 lb-ft. (420 Nm).
6. Install grease fittings (172) and fill block with grease. Refer to "LUBRICATION" section on page 21.

HA2-037 Hoist

Refer to Dwg. MHP0316 on page 68.

1. Pack bearing (407) with grease and position bearing (407) in hook center block (413) cavity.
2. Install threaded hook end into hook center block (413) and through bearing (407).
3. Install nut (405) being careful that threads are not crossed. Tighten nut (405) until snug then back nut (405) off until first dowel pin (406) hole is lined up. Install dowel (406) until flush with nut (405) diameter. Do not attempt to drive dowel pin (406) into nut until holes are aligned or threads on hook (408) will be damaged.
4. Lubricate and install 'O' rings (34) on sheave (41) in grooves provided. Using a press against the inner race of bearing (32) press bearings (32) onto sheave (41). Repeat the process for the opposite side.
5. Install the assembled sheave in the hook center block (413). Pack cavities in hook center block (413) and hook block (400) with grease.
6. Install hook block (400) and side plate (415) over bearings (32) and sheave (41) making sure dowel holes are lined up. Tap dowels (412) into position. Secure hook block and side plate with capscrews (402) using Loctite® 242. Torque capscrews (402) to 310 ft.-lb (420 Nm).
7. Install grease fittings (172) and fill block with grease. Refer to "LUBRICATION" section on page 21.

HA2-050 Hoist

Refer to Dwg. MHP0317 on page 68.

1. Pack bearing (407) with grease and position bearing (407) in hook center block (413) cavity.
2. Install threaded hook end into hook center block (413) and through bearing (407).
3. Install nut (405) being careful that threads are not crossed. Tighten nut (405) until snug then back nut (405) off until first dowel pin (406) hole is lined up. Install dowel (406) until flush with nut (405) diameter. Do not attempt to drive dowel

- pin (406) into nut until holes are aligned or threads on hook (408) will be damaged
4. Lubricate and install quad seals (34) on sheaves (41) in grooves provided. Using a press against the inner race of bearing (32) press bearings (32) onto both sides of sheaves (41).
 5. Install the assembled sheaves in the hook center block (413). Pack cavities in hook center block (413) and hook blocks (400) with grease.
 6. Install hook blocks (400) over bearings (32) and sheaves (41) making sure dowel holes are lined up. Tap dowels (412) into position. Secure hook blocks(400) with capscrews (402) using Loctite® 242. Torque capscrews (402) to 310 ft.-lb (420 Nm).
 7. Install grease fittings (172) and fill block with grease. Refer to "LUBRICATION" section on page 21.

Load Test

Prior to initial use, all new, extensively repaired, or altered hoists shall be load tested by or under the direction of personnel instructed in safety, maintenance and operation of this hoist. A written report must be maintained on record confirming the rating of the hoist.

1. Operate the hoist fully in both directions without a load. Hoist must operate smoothly, without evidence of binding. Response to operating controls must be quick and accurate.
2. Place a 10% load on hoist and operate hoist fully in both directions. Hoist must operate smoothly, without evidence of binding. Response to operating controls must be quick and accurate.
3. Dynamically load test hoist to **100%** of its rated capacity in accordance with ASME B30.16 standards. Hoist must operate smoothly, without evidence of binding. Response to operating controls must be quick and accurate.

NOTICE

• Testing to more than 100% may be necessary to comply with standards and regulations set forth in areas outside of the USA.

HA2 HOIST DESCRIPTION DRAWING

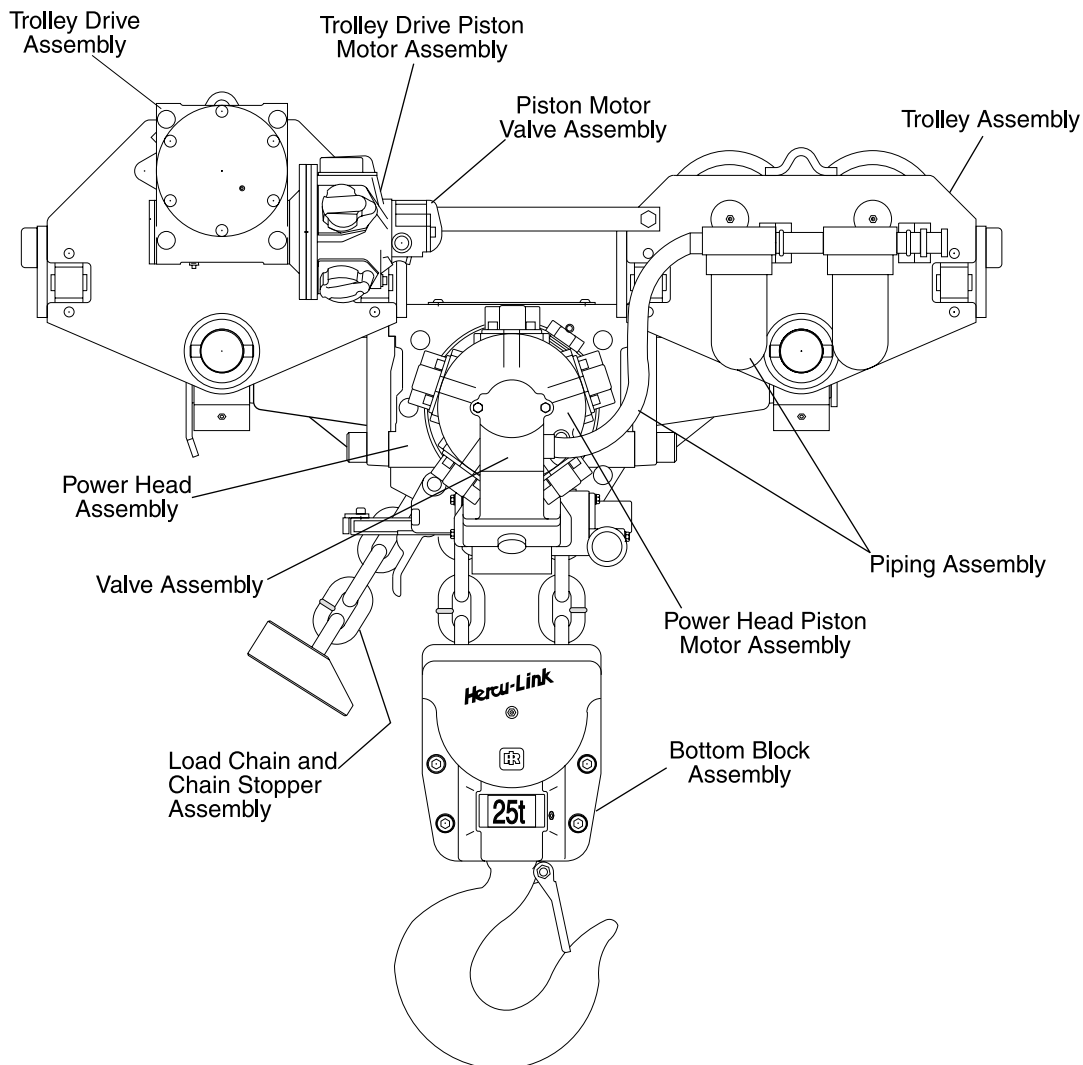

(Dwg. MHP0422)

HA2 HOIST DRAWINGS AND PARTS TABLE OF CONTENTS

Description	Page No.
Power Head Assembly Drawing (MHP0353).....	40
Power Head Piston Motor Assembly Drawing (MHP0359).....	42
Power Head Piston Motor Valve Assembly Drawing (MHP0382).....	44
Two Lever Pendant Assembly Drawing (MHP2235 and MHP2236).....	46
Four Lever Pendant and Emergency Stop Assembly Drawing (MHP2237 and MHP2238).....	48
Old Style Pendant with Emergency Stop Assembly Drawing (MHP0396).....	50
Old Style Pendant without Emergency Stop Assembly Drawing (MHP1706).....	52
Trolley Piston Motor Valve Assembly Drawing (MHP0415).....	54
Vane Motor Valve Assembly Drawing (MHP0407).....	55
Trolley Drive Vane Motor Assembly Drawing (MHP0379).....	56
Trolley Drive Piston Motor Assembly Drawing (MHP0381).....	58
12 Ton Trolley Assembly Drawing (MHP1525).....	60
25 Ton and Larger Trolley Assembly Drawing (MHP0282).....	62
Trolley Drive Assembly Drawing (MHP0306).....	64
Top Hook Assembly Drawings (MHP0344, MHP0345, MHP0346 and MHP0347).....	66
50 ton and 37-1/2 ton Bottom Block Assembly Drawings (MHP0317 and MHP0316).....	68
12-1/2 ton and 25 ton Bottom Block Assembly Drawings (MHP0314 and MHP0315).....	69
Chain Bucket Assembly Drawing (MHP1524).....	70
Load Chain and Chain Stopper Drawing (MHP0399).....	71
Hose Assembly Drawings (MHP0425).....	72
Hull Bumper Assembly Drawings (MHP0431 and MHP0433).....	73
Rope Control Assembly Drawing (MHP1515).....	74
Trolley Mount Piping Assembly Drawing (MHP1514).....	76
Hook-Mount Lubricator-Filter Piping Assembly Drawing (MHP0601).....	78
Mufflers Drawing (MHP1526).....	79
Label and Tag Parts Drawing (MHP1496).....	80

HOIST POWER HEAD ASSEMBLY PARTS DRAWING

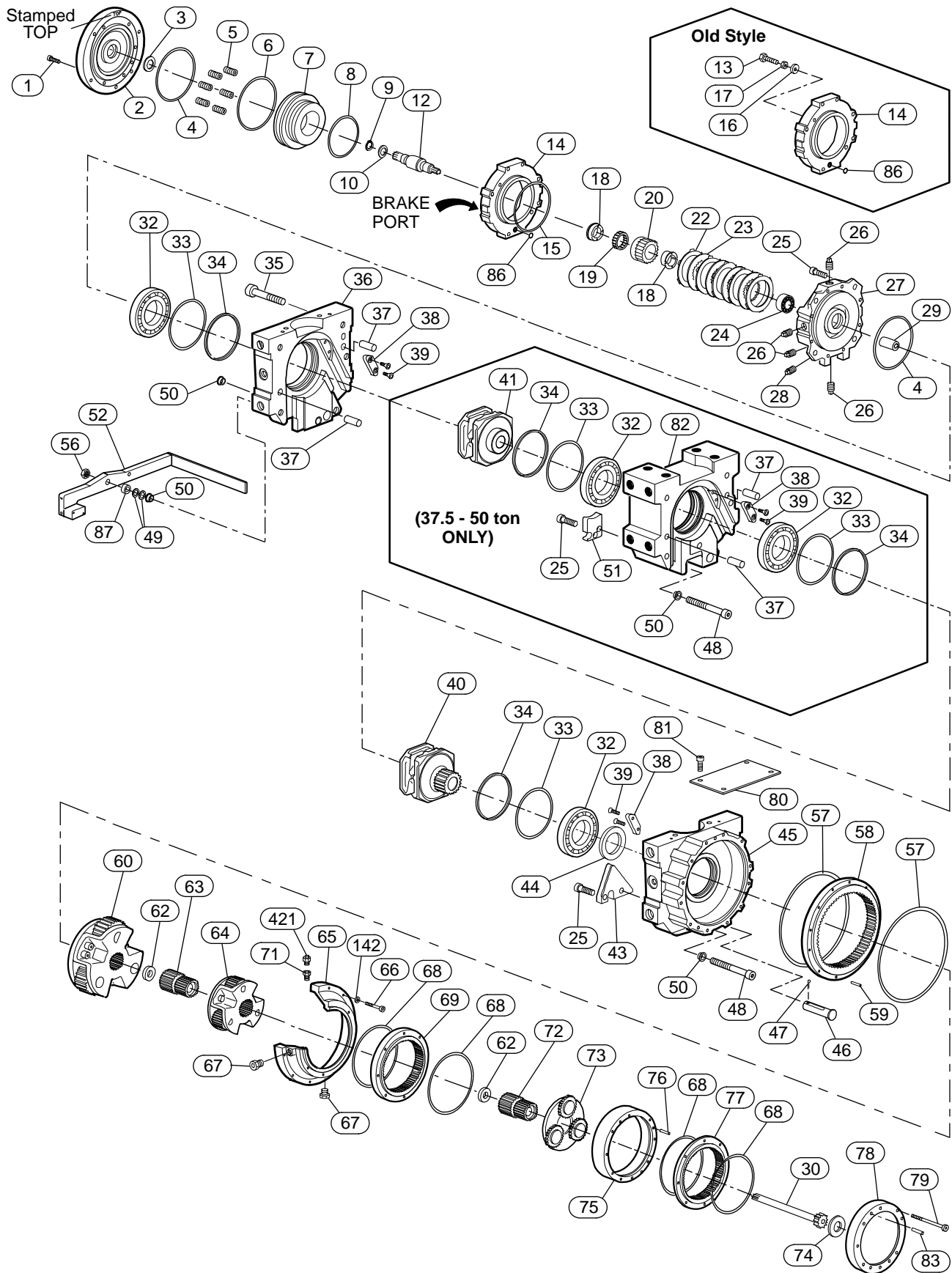

(Dwg. MHP0353)

HOIST POWER HEAD ASSEMBLY PARTS LIST

Item No.	Description of Part	Qty Total	Part Number	Item No.	Description of Part	Qty Total	Part Number
1	Capscrew	8	71059901	48	Capscrew	1	71322143
2	Adapter	1	11954	49	Washer	2	52915
• 3	Oil Seal	1	50541	50	Bushing	2 (3)	52675
• 4	'O' Ring	2	52670	51	Stripper (37-1/2 and 50 ton)	1	13001
5	Spring	6	50751	52	Limit Arm Assembly (includes items, 49-50, 56, and 87 for 12-1/2 and 25 ton)	1	16219
• 6	Seal	1	71107726		Limit Arm Assembly (includes items, 49-50, 56, and 87 for 37-1/2 and 50 ton)		17290
7	Brake Piston *	1	22177	56	Nut	1	54661
• 8	Seal	1	71107718	• 57	'O' Ring	2	71106728
9	Retainer Ring	1	50810	58	Ring Gear	1	71068639
10	Washer	1	50528	59	Pin	3	71106710
12	Shaft	1	12009	60	Planetary Assembly	1	71068621
13	Capscrew**	2	71337505	62	Thrust Washer	2	71068647
14	Cylinder	1	11951	63	Sun Gear	1	71068613
• 15	'O' Ring	1	52730	64	Planetary Assembly	1	71068555
• 16	Seal***	2	54655	65	Input Housing	1	71068589
17	Nut**	2	71328355	66	Capscrew	12	71267405
18	Bushing	2	12011	67	Plug	3	71068571
19	Sprag Clutch	1	52666	• 68	'O' Ring	4	52149
20	Brake Hub	1	12010	69	Ring Gear	1	71068548
22	Friction Disc	5	12013	71	Fitting, Bushing	1	54659
23	Brake Disc	4	12012	72	Sun Gear	1	71068530
24	Bearing	1	52665	73	Planetary Assembly	1	71107650
25	Capscrew	4	71316525	74	Thrust Washer	1	52950
26	Plug	4	54912	75	Spacer	1	71068522
27	Brake Housing	1	11953	76	Pin	2	71068472
28	Plug	1	54292	77	Ring Gear	1	71068514
29	Motor Coupling	1	11999	78	Cover	1	71068654
30	Drive Shaft	1	11998	79	Capscrew	8	71106736
32	Bearing	2 (4)	54483	80	Plate (12-1/2 and 25 ton)	1	12844
• 33	'O' Ring	2 (4)	54341		Plate (37-1/2 and 50 ton)		17098
• 34	Seal	2 (4)	71007405	81	Capscrew	4	71322184
35	Capscrew (12-1/2 and 25 ton)	4	71322085	82	Frame (37-1/2 and 50 ton)	1	11850
	Capscrew (37-1/2 and 50 ton)	5	71328769	83	Pin	2	71068464
36	Frame (12-1/2 and 25 ton)	1	11844	• 86	'O' Ring**	1	52662
	Frame (37-1/2 and 50 ton)		11848	87	Spacer	1	23431-046
37	Pin	2 (4)	71328777	142	Lockwasher	12	50181
38	Insert	1 (2)	9147-1	421	Breather	1	52024
39	Capscrew	2 (4)	71322101	490	Reducer Assembly (includes items 57 through 79, 83 and 421)	---	52659
40	Sheave, Drive	1	11980				
41	Sheave, Idle (37-1/2 and 50 ton)	1	11979				
43	Stripper	1	12008				
44	Spacer	1	12007				
45	Frame (Reducer Side)	1	11846				
46	Pin (Chain Anchor - 50 ton)	1	16046				
47	Pin, Cotter	1	51021				

• Recommended Spare for one hoist, 2 years of normal operation.

* Refer to "BRAKE UPGRADE NOTICE" on page 81.

** Only required on older style hoists

POWER HEAD PISTON MOTOR ASSEMBLY PARTS DRAWING

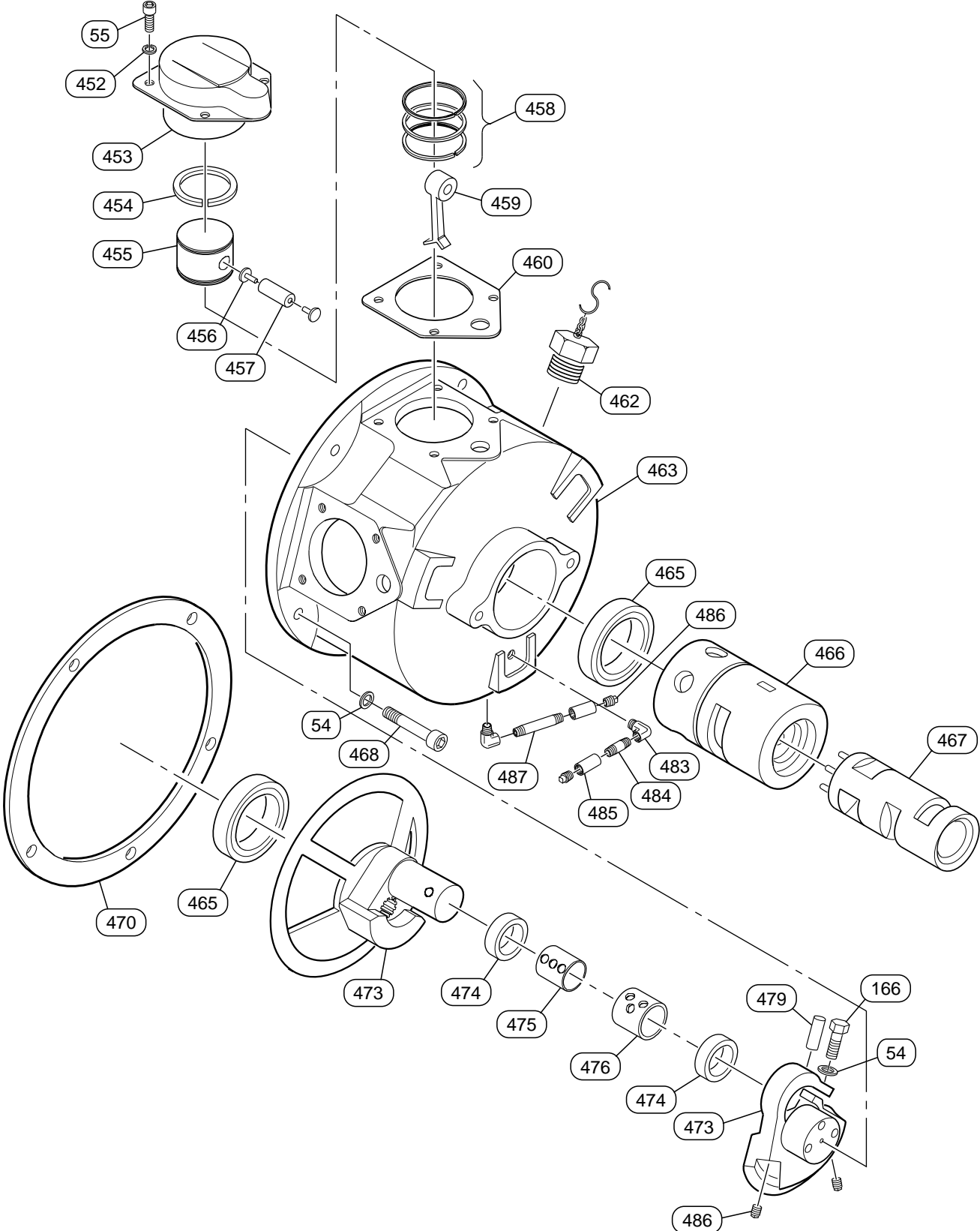

(Dwg. MHP0359)

POWER HEAD PISTON MOTOR ASSEMBLY PARTS LIST

Item No.	Description of Part	Qty Total	Part Number
450	Motor Assembly (incl's items 54, 55, 166, 452-465 and 467-479)	1	50259-2
54	Lockwasher	6	50200
55	Capscrew	20	71328371
166	Capscrew	1	51712
452	Washer (copper)	20	94-027-20
453	Cylinder	5	94-024
454	Compression Ring	5	Order Kit 71032932
455	Piston Assembly (incl's items 454, 457 and 458)	5	94-010A
456	Plug	10	Order Item 457
457	Wrist Pin Assembly (incl's item 456)	5	94-011-1A
458	Oil Ring	5	Order Kit 71032932
459	Connecting Rod	5	94-009
460	Gasket	5	94-025-5
462	Vent Cap Assembly	1	26604
463	Motor Housing	1	Not Sold Separately
465	Bearing	2	50944
466	Rotary Bushing	1	20-2
467	Rotary Valve	1	94-019
468	Capscrew	5	71328389
470	Gasket	1	94-029
473	Crankshaft Assembly (incl's items 54, 166, 473-476, 479, 486)	1	94-001
474	Connecting Rod Ring	2	94-008
475	Sleeve	1	94-007
476	Bushing	1	94-006
479	Pin	1	94-004
483	Fitting, Elbow	2	71127815
484	Fitting, Nipple	1	50859
485	Pipe Coupling	2	53876
486	Plug	3	51599
487	Fitting, Nipple	1	71107692
• 801	Service Kit (includes items 452, 454, 458, 460 and 470)	1	71032932

- Recommended spare for one hoist, 2 years of normal service.

VALVE ASSEMBLY PARTS DRAWING

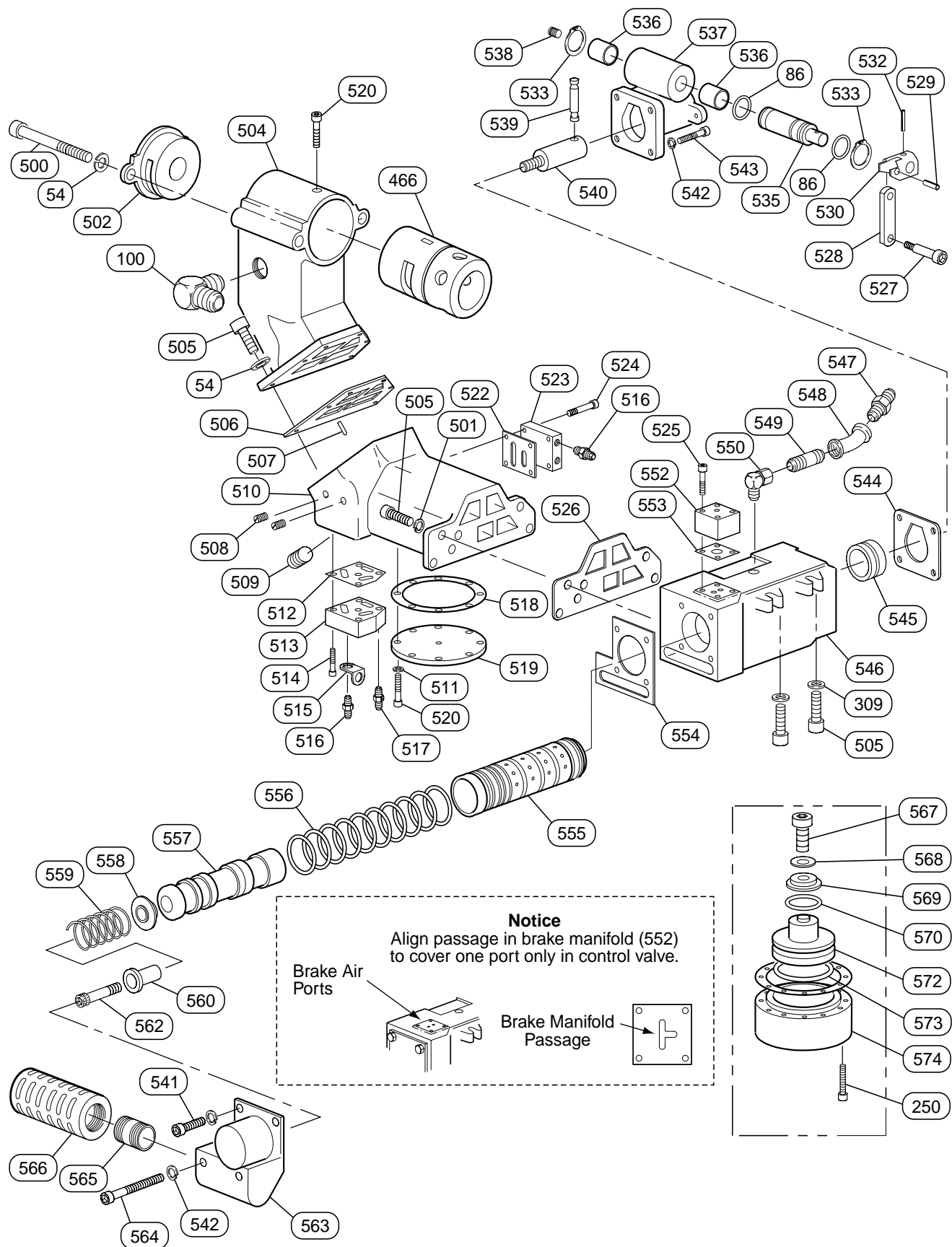

(Dwg. MHP0382)

VALVE ASSEMBLY PARTS LIST

Item No.	Description of Part	Qty Total	Part Number	Item No.	Description of Part	Qty Total	Part Number
28	Plug	1	54292	536	Bushing	2	50498
54	Lockwasher	10	50200	537	Cap (incl's item 536)	1	11763
• 86	'O' Ring	2	52662	538	Setscrew	1	71069066
100	Fitting, Elbow	1	53030	539	Link	1	11768
250	Capscrew	8	51095	540	Push Rod	1	11767
309	Washer	4	71055206	541	Capscrew	2	71128938
466	Rotary Bushing	1	20-2	542	Lockwasher	8	71146625
500	Capscrew	2	53840	543	Capscrew	4	54558
501	Lockwasher	4	71268908	• 544	Gasket	1	12023
502	Valve Cap	1	15031	545	Spacer	1	12022
504	Manifold Section*	1	Order B-10064	546	Housing	1	11962
505	Capscrew	6	51766	547	Fitting, Nipple	1	54623
506	Gasket	1	15037B	548	Fitting, Pipe Elbow	1	54624
507	Dowel	2	71328363	549	Fitting, Nipple	1	52809
508	Plug	4	54247	550	Fitting, Elbow	1	54611
509	Plug	1		552	Manifold (Brake)	1	13372
510	Manifold Section*	1	Order B-10064	• 553	Gasket	1	13373
511	Lockwasher	8	71268890	• 554	Gasket	1	12024
512	Gasket	1	9853	555	Sleeve**	1	21139
513	Block	1	9426	• 556	'O' Ring	10	51553
514	Capscrew	4	71069033	557	Spool**	1	21139
515	Bracket	1	8909	558	Stop	1	12019
516	Fitting	4	52092	559	Spring	1	71798
517	Fitting, Vented	4	18647	560	Spring Holder	1	12018
• 518	Gasket	1	9857	562	Shoulder Screw	1	53845
519	Cover Plate	1	20250	563	End Cap	1	11981
520	Capscrew	9	50851	564	Capscrew	2	71146609
• 522	Gasket	1	9856	565	Fitting, Nipple	1	51704
523	Manifold (Trolley)	1	9439	566	Muffler, 1-1/4 in.	1	52465
524	Capscrew	4	71111918	567	Capscrew	1	50156
525	Capscrew	4	71146617	568	Washer	1	9438-B
• 526	Gasket	1	9855	569	Piston Spacer	1	9438-A
527	Shoulder Bolt	1	71085179	• 570	'O' Ring	1	51554
528	Link	1	21289	572	Piston	1	9403
529	Pin	1	51974	• 573	'O' Ring	1	5155
530	Clevis	1	11220	574	Housing	1	10063
532	Pin	1	71146633	800	Control Valve Assembly	1	12354
533	Retainer Ring	2	52663	• 802	Control Valve Service Kit (incl's items 86, 526, 544, 553, 554, 556, and 559)	1	71034573
535	Shaft	1	11769				

• Recommended spare for one hoist, 2 years of normal service.

* Manifold includes items 504 through 510 and 4 of item 54.

** Not available separately. Order kit number 21139 for one each of sleeve (item 555) and spool (item 557).

TWO LEVER PENDANT ASSEMBLY PARTS DRAWINGS

Pendant without Emergency

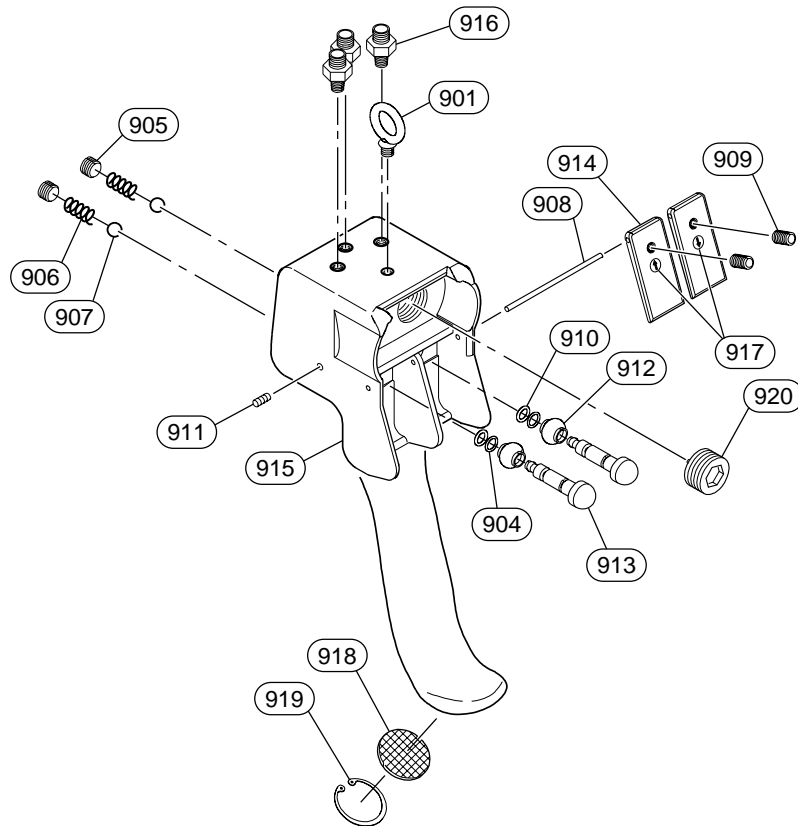

(Dwg. MHP2235)

Pendant with Emergency Stop

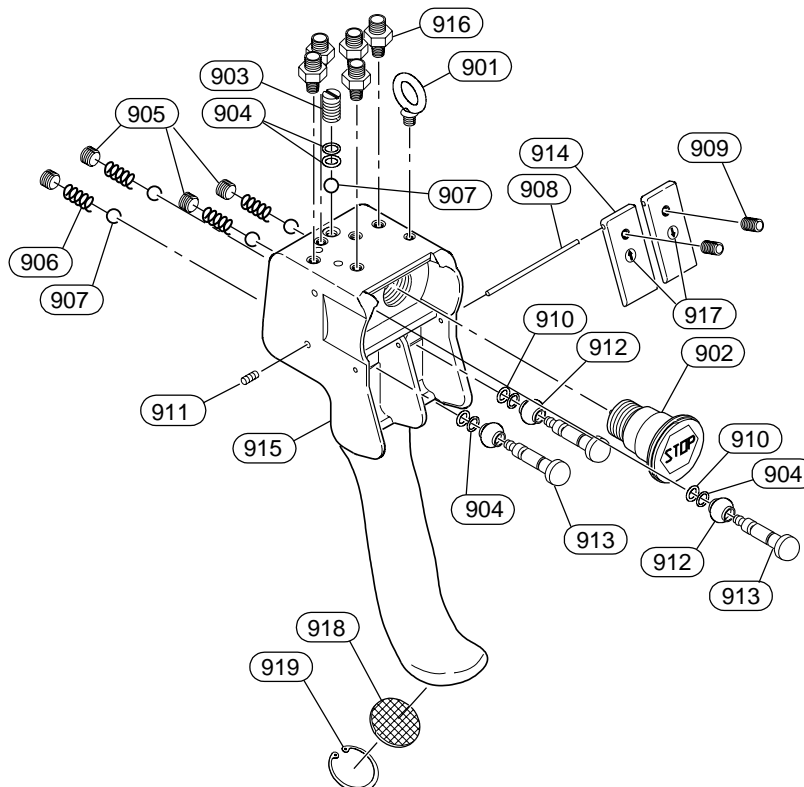

(Dwg. MHP2236)

TWO LEVER PENDANT ASSEMBLY PARTS LIST

Item No.	Description of Part	Qty Total	Part Number	
			Without E-Stop	With E-Stop
820	Pendant Assembly	1	PHS2E	PHS2E-U
901	Lifting Eye	1	64222332	
902	Emergency Stop Valve	1	---	95790108
903	Plug	1	---	95790106
• 904	'O' Ring	2(5)	58209229	
905	Plug	2(4)	65107741	
906	Spring	2(4)	69128541	
• 907	Ball	2(5)	69401625	
908	Pin	1	95790040	
909	Setscrew	2	42008607	
• 910	'O' Ring	2(3)	58235329	
911	Setscrew	2(3)	42008307	
912	Protector	2(3)	95790107	
913	Valve	2(3)	95790104	
914	Lever	2	95790122	
• 915	Pendant Handle*	1	Order item 820	
916	Fitting, Nipple	3(5)	71078158	
917	Label Kit	1	95790111	
918	Exhaust Washer	1	95790114	
919	Retainer Ring	1	47713030	
• 920	Plug	1	65129541	---
**	Label: Read the Manual	1	96180098	
**	Label: Do Not Use for Lifting Personnel	1	96180100	

• Recommended spares for one hoist, 2 years of normal service.

* Not sold separately. Order new Pendant.

** Not Illustrated

() Quantity Required for Pendants with Emergency Stop

FOUR LEVER PENDANT AND EMERGENCY STOP DRAWING

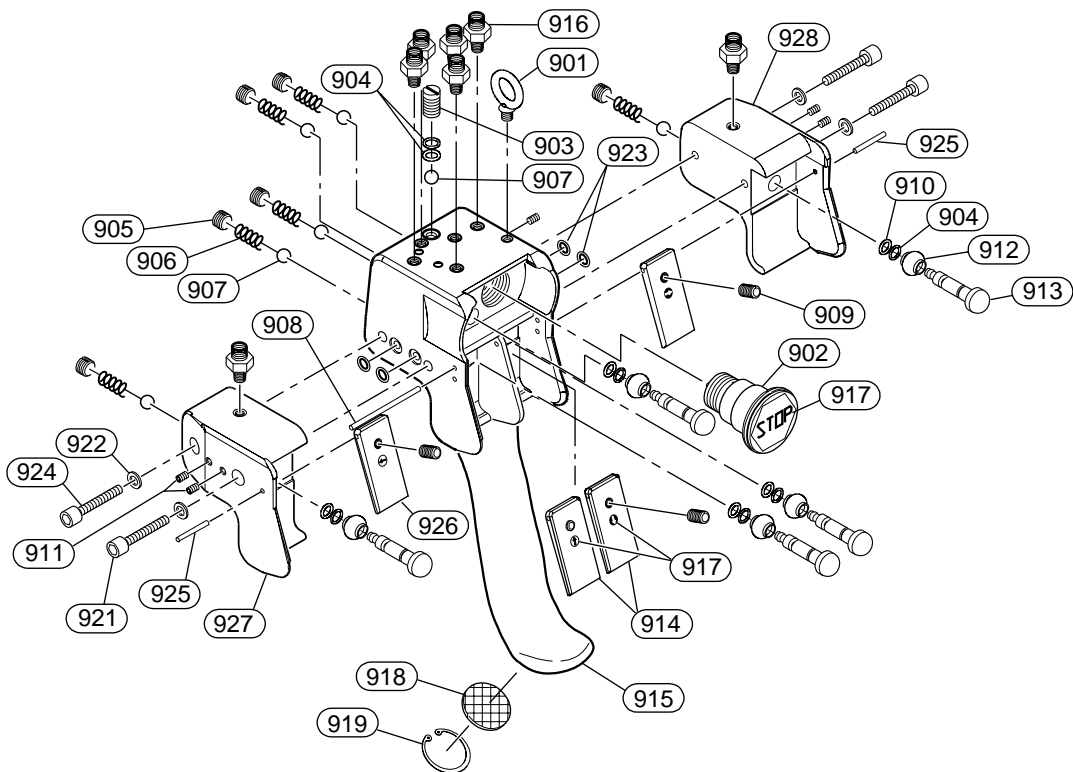

(Dwg. MHP2237)

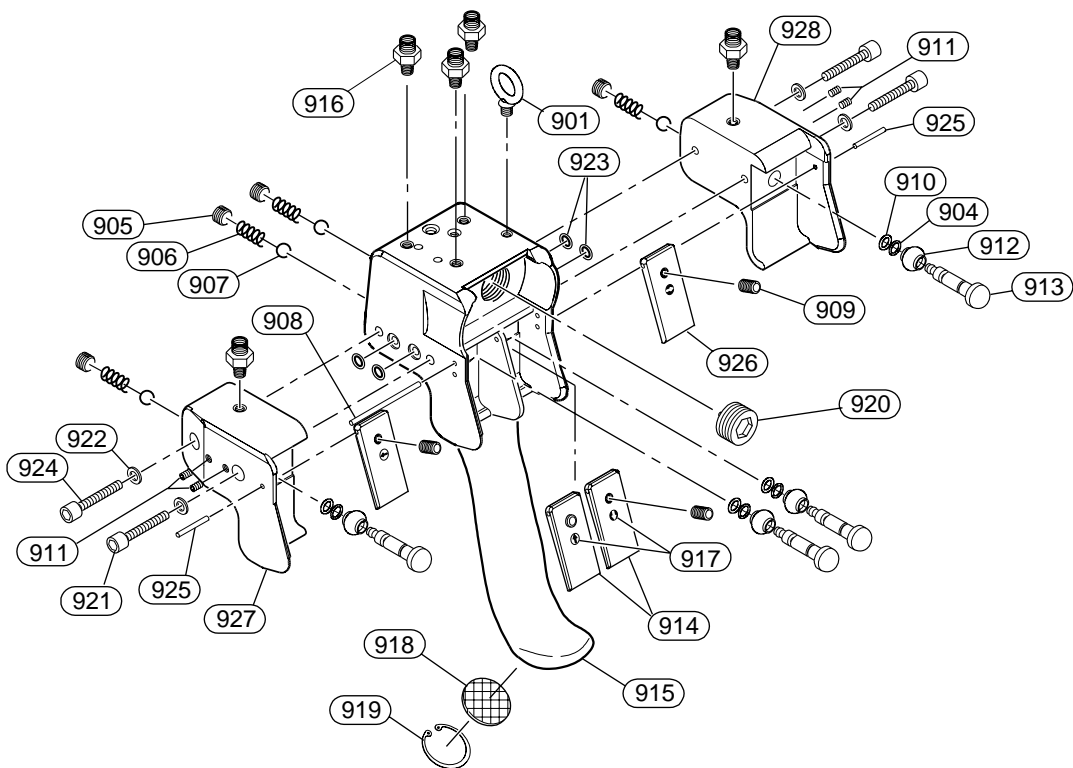

(Dwg. MHP2238)

FOUR LEVER PENDANT CONTROL ASSEMBLY PARTS LIST

Item No.	Description of Part	Qty Total	Part Number	
			Without E-Stop	With E-Stop
820	Pendant Assembly	1	PHS4E	PHS4E-U
901	Lifting Eye	1	64222332	
902	Emergency Stop Valve	1	---	95790108
903	Plug	1	---	95790106
• 904	'O' Ring	4(7)	58209229	
905	Plug	4(6)	65107741	
906	Spring	4(6)	69128541	
• 907	Ball	4(7)	69401625	
908	Pin	1	95790040	
909	Setscrew	4	42008607	
• 910	'O' Ring	4(5)	58235329	
911	Setscrew	4(5)	42008307	
912	Protector	4(5)	95790107	
913	Valve	4(5)	95790104	
914	Lever	2	95790122	
• 915	Pendant Handle*	1	Order item 820	
916	Fitting, Nipple	5(7)	71078158	
917	Label Kit	1	95790111	
918	Exhaust Washer	1	67600303	
919	Retainer Ring	1	47713030	
• 920	Plug	1	95790097	---
921	Capscrew	2	41322106	
922	Washer	4	45201005	
• 923	'O' Ring	4	58218229	
924	Screw	2	41330506	
925	Pin	2	95790127	
926	Lever	2	95790128	
927	Attachment (Left)	1	95790125	
928	Attachment (Right)	1	95790126	
**	Label: "Do Not Use for Lifting Personnel"	1	65129541	---
**	Label: "Read the Manual"	1	96180098	

• Recommended spares for one hoist, 2 years of normal service.

* Not sold separately. Order new Pendant.

** Not illustrated

() Quantity Required for Pendants with Emergency Stop

OLD STYLE PENDANT (WITH EMERGENCY STOP) ASSEMBLY PARTS DRAWING

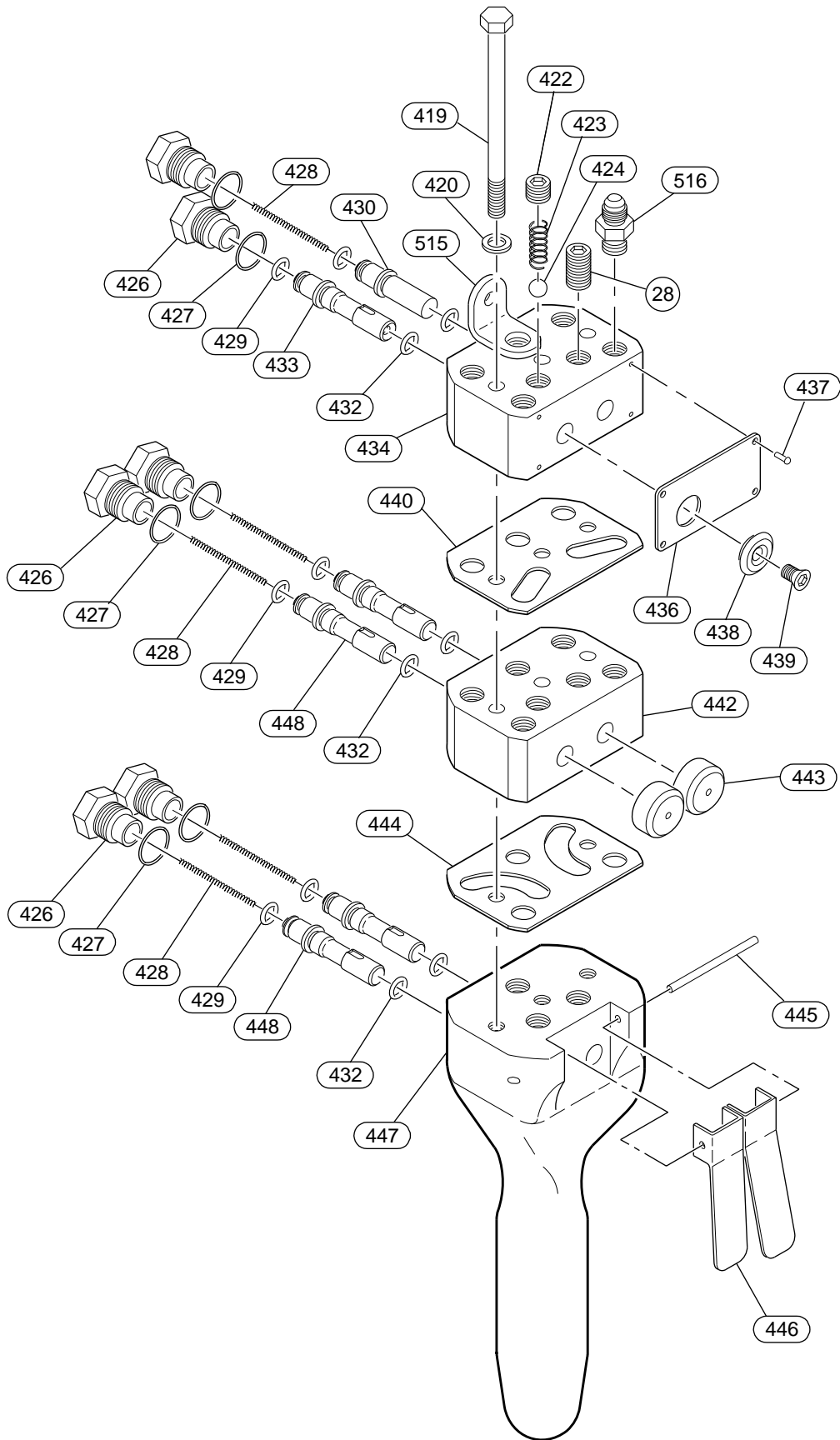

(Dwg. MHP0396)

OLD STYLE PENDANT (WITH EMERGENCY STOP) ASSEMBLY PARTS LIST

Item No.	Description of Part	Qty Total	Part Number			
			2 Lever		4 Lever	
			Without E-stop	With E-stop	Without E-stop	With E-stop
28	Plug	3	54292			
417	Pendant Assembly (Standard)	1	---	18952	51412	18956
	Pendant Assembly Marine (Anodized)		21685	15003-1	19755	15002-1
419	Capscrew	2	---	51675		51679
420	Washer	2		51676		
422	Plug	1		51674	---	51674
423	Spring	1		51414		51414
424	Ball	1		51552		51552
426	Cap	See ()		9486 (2)	9486 (4)	51233 (4)
427	'O' Ring	See ()	51233 (2)	51233 (4)		51233 (6)
428	Spring	See ()	51235 (2)	51235 (3)	51235 (4)	51235 (5)
429	'O' Ring	See ()	50846 (2)	50846 (4)		50846 (6)
430	Spool (Emergency Stop)	1	---			9071-4
432	'O' Ring	See ()	51234 (2)	51234 (4)	51234 (4)	51234 (6)
433	Spool (Emergency Stop)	1	---	9071-2	---	9071-2
434	Block (Emergency Stop)	1		9984		9424
435	Spool (Trolley)	2	---		9071-3	
436	Nameplate	1	---	9436	---	9436
437	Drive Screw	4		51673		51673
438	Emergency Stop Button	1		9414		9414
439	Capscrew	1		53869		53869
440	Gasket	1	---	9854		
442	Block (Trolley)	1		51678		
443	Button (Trolley)	2		9414-1		
444	Gasket	1		9852		
445	Pin	1(2)	51671			
446	Lever	See ()	51413 (2)		51413 (4)	
447	Pendant Handle (Standard)	1	Order item 417			
	Pendant Handle Marine (Anodized)					
448	Spool (Hoist)	2	9071-1			
515	Bracket	1	8909			
516	Fitting	See ()	52092 (4)		52092 (5)	52092 (6)
• 803	Pendant Service Kit (includes items 423, 424, 427-429, 432, 440 and 444)	1	---		9750-4	

• Recommended spare for one hoist, 2 years of normal service.

OLD STYLE PENDANT (WITHOUT EMERGENCY STOP) ASSEMBLY DRAWING

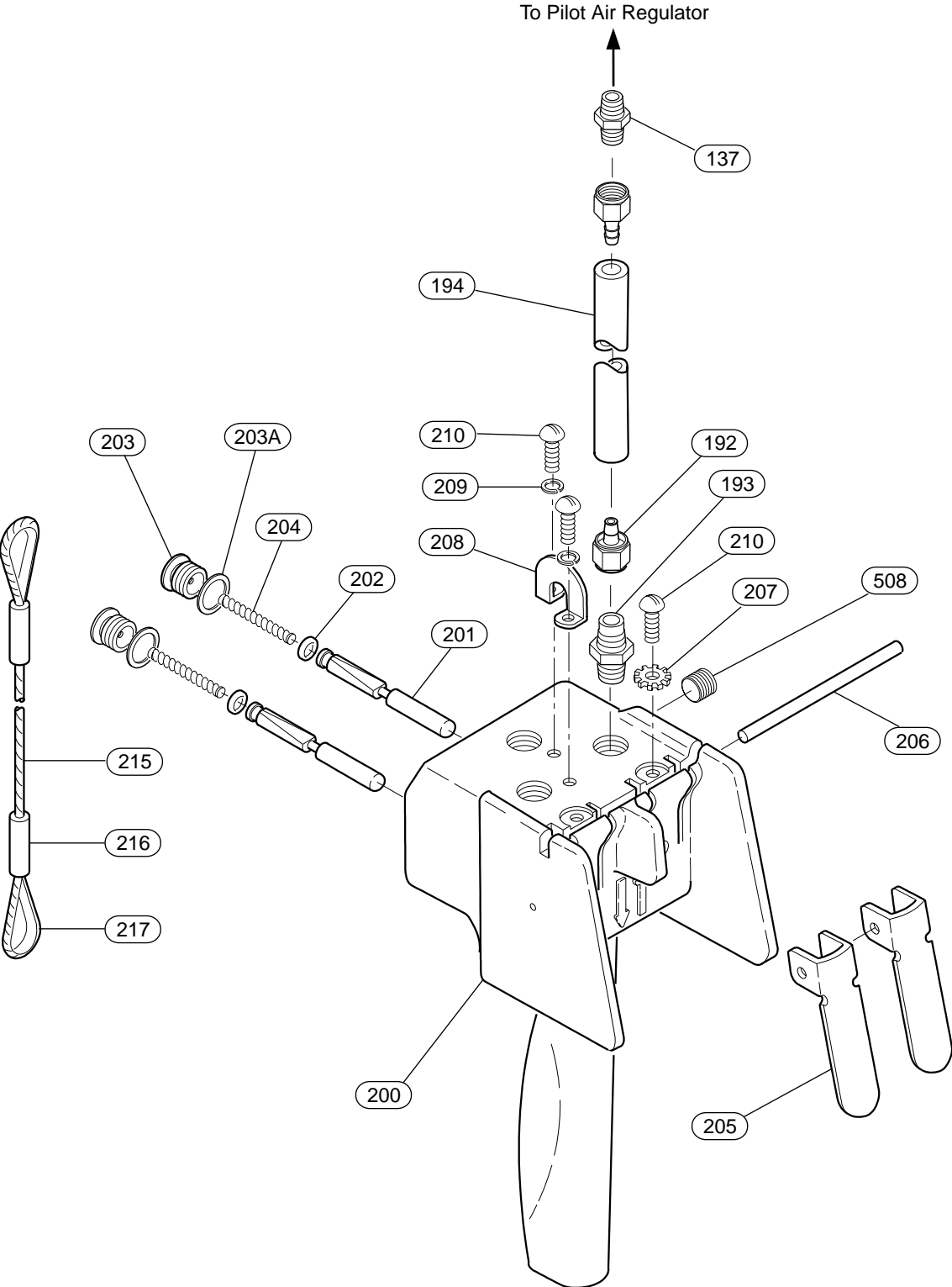

(Dwg. MHP1706)

OLD STYLE PENDANT (WITHOUT EMERGENCY STOP) PARTS LIST

Item No.	Description of Part	Qty Total	Part Number
482	Pendant Body Assembly (incl's items 200-210, and 220)	1	MLK-A269C
137	Fitting, Nipple	3	53939
189*	Tie Wrap	As req'd every 3-5 feet	54235
192	Fitting, Hose End	6	51029
193	Fitting, Nipple	3	71048268
194	Hose (Bulk)	Specify Length	50923
200	Pendant Handle	1	Order item 482
201	Pendant Throttle Valve	2	MLK-K264B
• 202	Throttle Valve Face	2	R000BR1C-283
203	Pendant Throttle Valve Cap	2	MLK-K266A
203A	Valve Cap Gasket	2	MLK-239
• 204	Pendant Throttle Valve Spring	4	MLK-51A
205	Pendant Throttle Lever	2	MLK-273
206	Throttle Lever Pin	1	DLC-120A
207	Lockwasher	2	D02-138
208	Strain Relief Support	1	MLK-540
209	Relief Support Lockwasher	2	H54U-352-10
210	Screw	4	MF-31
215	Strain Relief Cable	Specify Length	BWR3A
216	Clamping Sleeve	2	MLK-521
217	Clamping Thimble	2	MLK-602
508	Plug	1	54247
---	Strain Relief Assembly (incl's items 215 through 217)	1	MLK-LWR3A

• Recommended spares for one hoist, 2 years of normal service.

* Refer to Dwg. MHP0425 on page 72.

TROLLEY PISTON MOTOR VALVE ASSEMBLY DRAWING AND PARTS LIST

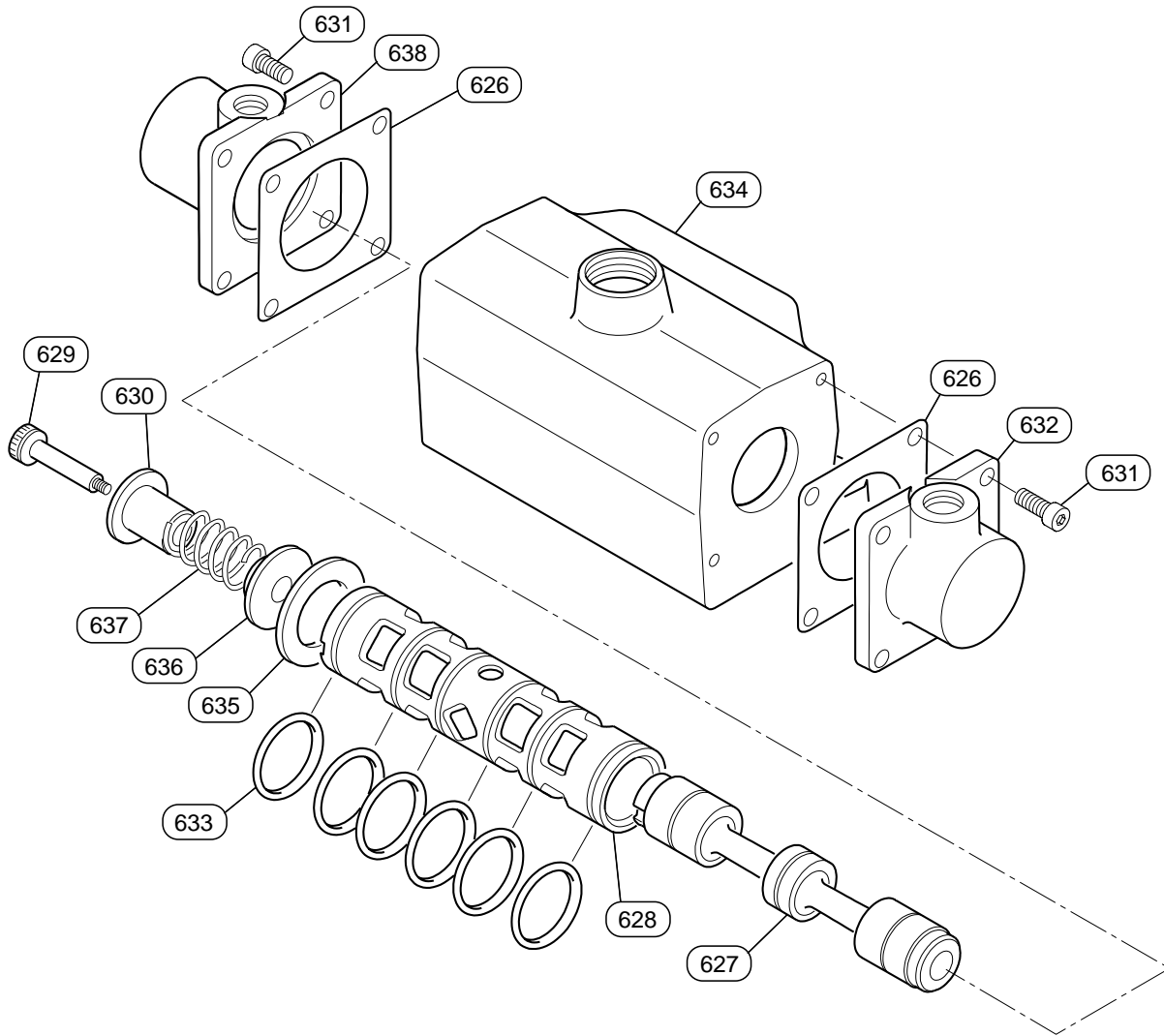

(Dwg. MHP0415)

Item No.	Description of Part	Qty Total	Part Number
625	Valve Assembly (incl's items 626 thru 638)	1	51700
626	End Cap Gasket	2	51978
627	Valve Spool	1	Order item 625
628	Valve Sleeve	1	
629	Shoulder Screw	1	9640-4
630	Centering Shaft Guide	1	9640-5
631	Bolt	8	9640-6
632	End Cap	1	9640-7
633	'O' Ring	6	51632
634	Valve Body	1	Order item 625
635	Spacer	1	9640-10
636	Washer	1	9640-11
637	Spring	1	54925
638	End Cap	1	9640-13
• 804	Valve Service Kit (includes items 626 and 633)	1	9750-13

• Recommended spares for one hoist, 2 years of normal service.

VANE MOTOR VALVE ASSEMBLY DRAWING AND PARTS LIST

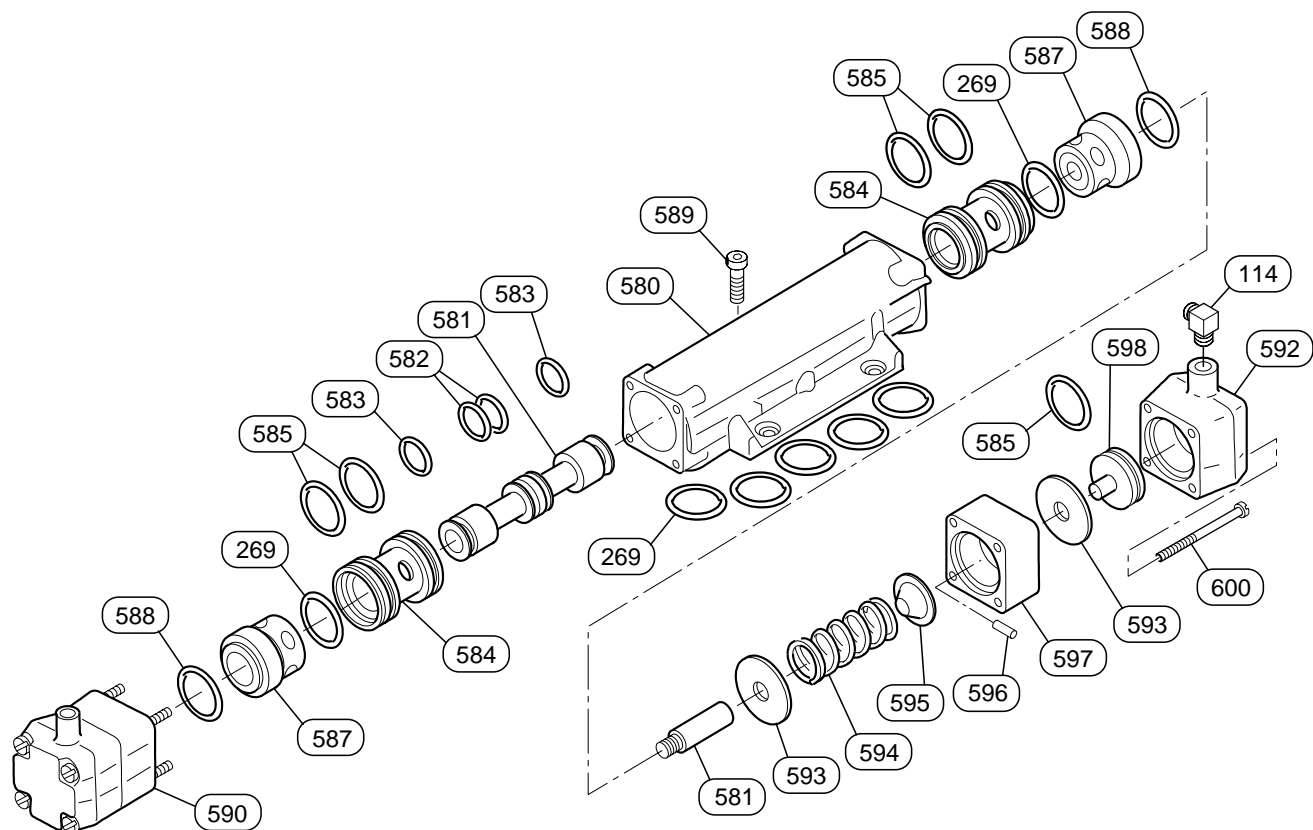

(Dwg. MHP0407)

Item No.	Description of Part	Qty Total	Part Number	Item No.	Description of Part	Qty Total	Part Number
270	Pilot Control Valve (incl's items 114, 269 and 580 thru 600)	1	50431	587	Retainer	2	4502-43
				• 588	'O' Ring	2	P-1000-19
				589	Capscrew	1	8325-93
114	Fitting, Elbow	2	51281	590	Cap Assembly*	1	SA-4302-83
• 269	'O' Ring	7	P-1100-13	592	Pilot Cap	2	4302-11
580	Body	1	Order item 270	593	Washer	4	4302-02
581	Plunger	1	71060198	594	Spring	2	71060206
• 582	'O' Ring	2	P-1100-10	595	Spring Cap	2	4302-14
• 583	'O' Ring	2	P-1000-10	596	Pin	2	4302-22
584	Bushing	2	4502-04	597	Pilot Spacer	2	4302-32
• 585	'O' Ring	5	P-1000-17	598	Piston	2	4302-38
				600	Screw	8	PFS-1032-36

• Recommended spares for one hoist, 2 years of normal service.

* Item 590 includes items 592 to 598 and 585.

TROLLEY DRIVE VANE MOTOR ASSEMBLY PARTS DRAWING

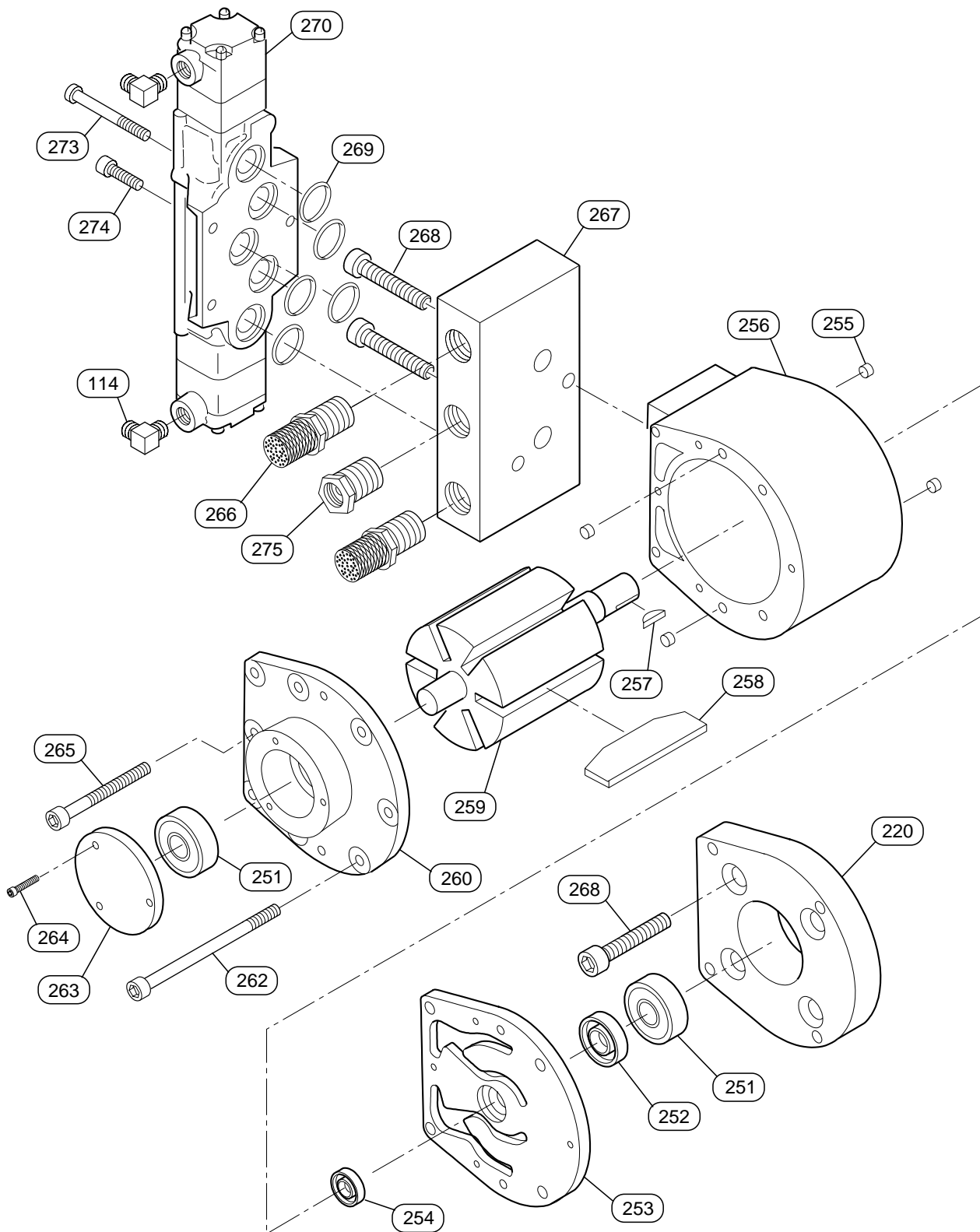

(Dwg. MHP0379)

TROLLEY DRIVE VANE MOTOR ASSEMBLY PARTS LIST

Item No.	Description of Part	Qty Total	Part Number
199	Motor Assembly (incl's items 251 thru 265)	1	4864
114	Fitting, Elbow	2	51281
220	Motor Adapter	1	6553
251	Bearing	2	51074
252	Seal	1	50840
253	Cover	1	6554
254	Seal	1	51591
255	Dowel	4	51084
256	Cylinder	1	3131
257	Shaft Key	1	50273
258	Vane	6	4335-6
259	Shaft and Rotor	1	4333-A
260	Cover	1	3761
262	Capscrew	4	51080
263	Cap	1	4334
264	Capscrew	3	71328751
265	Capscrew	4	51078
266	Muffler	2	50593
267	Valve Manifold	1	8466
268	Capscrew	6	71328512
269	'O' Ring	5	P-1100-13
270	Pilot Control Valve	1	50431
273	Capscrew	1	71319057
274	Capscrew	2	
275	Fitting, Reducer	1	54913
• 805	Repair Kit (incl's items 251, 252, 254, 255, 258, 262, 264 and 265)	1	1000P60-VMK

- Recommended spares for one hoist, 2 years of normal service.

TROLLEY DRIVE PISTON MOTOR ASSEMBLY PARTS DRAWING

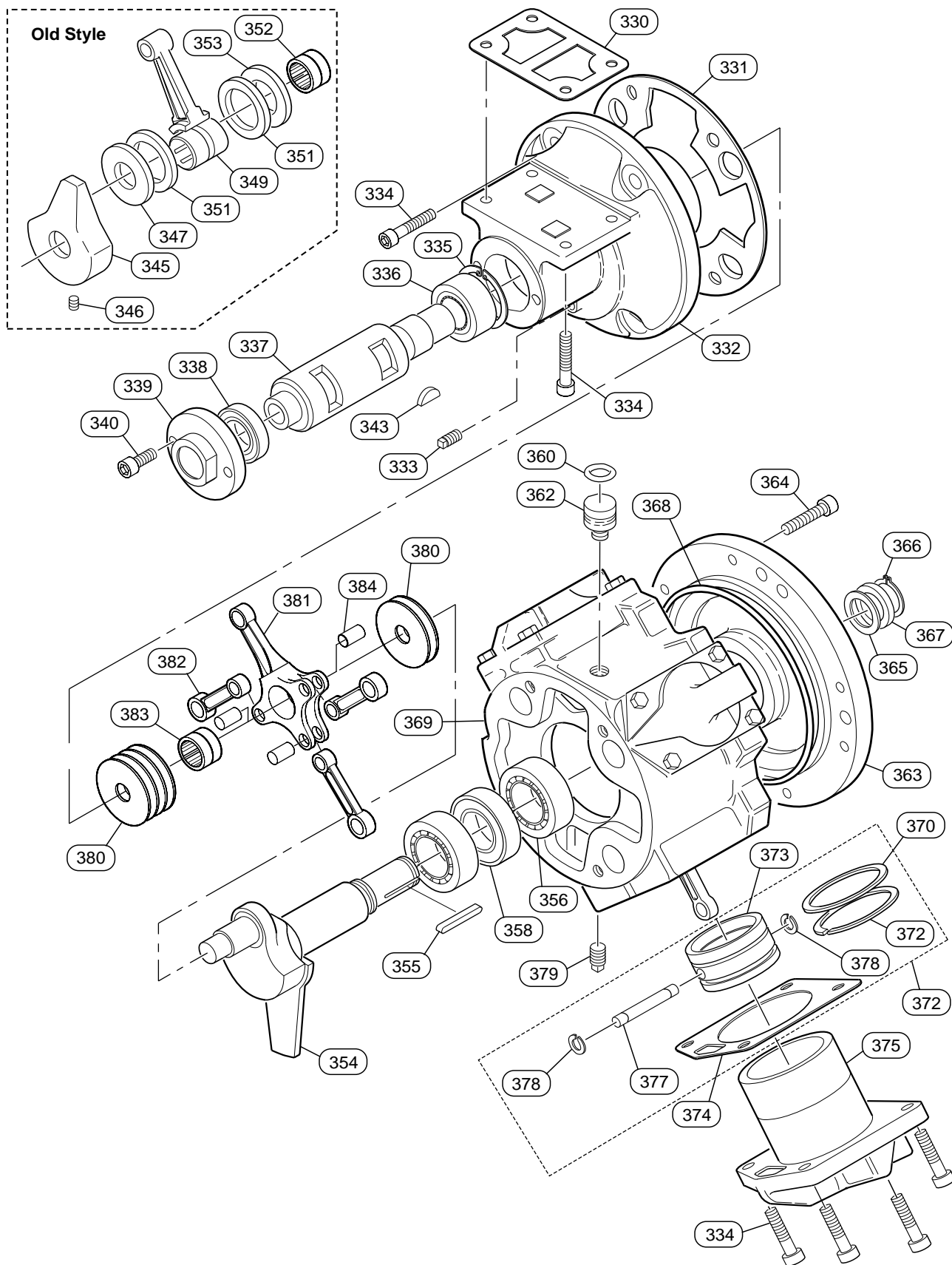

(Dwg. MHP0381)

TROLLEY DRIVE PISTON MOTOR ASSEMBLY PARTS LIST

Item No.	Description of Part	Qty Total	Part Number	Item No.	Description of Part	Qty Total	Part Number
329	Motor Assembly (incl's items 330 thru 379)	1	52151	363	Flange Plate	1	71029680
				364	Capscrew	4	71029870
330	Gasket	1	71018386	365	Shim	5	71029631
331	Gasket	1	71018394	366	Retainer Ring	1	71029599
332	Rotary Valve Housing	1	71028252	367	Spacer	1	71029615
333	Plug (Steel)	1	54658	368	'O' Ring	1	71029706
	Plug (Brass)		71112247	369	Motor Housing	1	Order item 329
334	Capscrew	24	71030084	370	Oil Ring	4	71018428
335	Retainer Ring	1	71028328	372	Compression Ring	8	71018410
336	Bearing	1	71028310	373	Piston Assembly (incl's items 370, 372, 377 and 378)	4	71029557
337	Rotary Valve	1	71028245				
338	Bearing	1	71028237	374	Gasket	4	71018402
339	Cover	1	71029854	375	Cylinder	4	71028336
340	Capscrew	2	71030134	377	Wrist Pin	4	Order item 373
343	Key	1	71030068	378	Retaining Ring	8	Order item 373
345	Balance Weight	Not available	Order Kit 149-081	379	Plug	1	71029722
346	Setscrew			380	Spacer 0.069 in (1.75 mm)	As Req'd	71378632
347	Spacer 0.060 in. (1.5 mm)						71378640
	Spacer 0.010 in. (0.25 mm)						71378657
	Spacer 0.060 in. (1.5 mm)						71378665
	Spacer 0.060 in. (1.5 mm)						71378665
	349			Connecting Rod	1	71378574	
351	Spacer			3	71378582		
352	Bearing			1	71378590		
353	Spacer			3	71378608		
354	Crankshaft	1	71378616				
355	Key	1	71029664	• 806	Motor Repair Kit (incl's items 330, 331, 358, 368, 370, 372 and 374)	1	71028120
356	Bearing	2	71030225			Complete Motor Retrofit Kit (incl's complete motor assy and associated mounting)	71388672
358	Seal	1	71029904				
360	'O' Ring (shipping only)	1	71018444				
362	Breather Plug	1	71030167				
362	Breather Plug	1	71030175				

• Recommended spare for one hoist, 2 years of normal service.

Note: Hoists with serial numbers above HL0190300 will have new style connecting rod assembly.

12.5 TON TROLLEY ASSEMBLY DRAWING

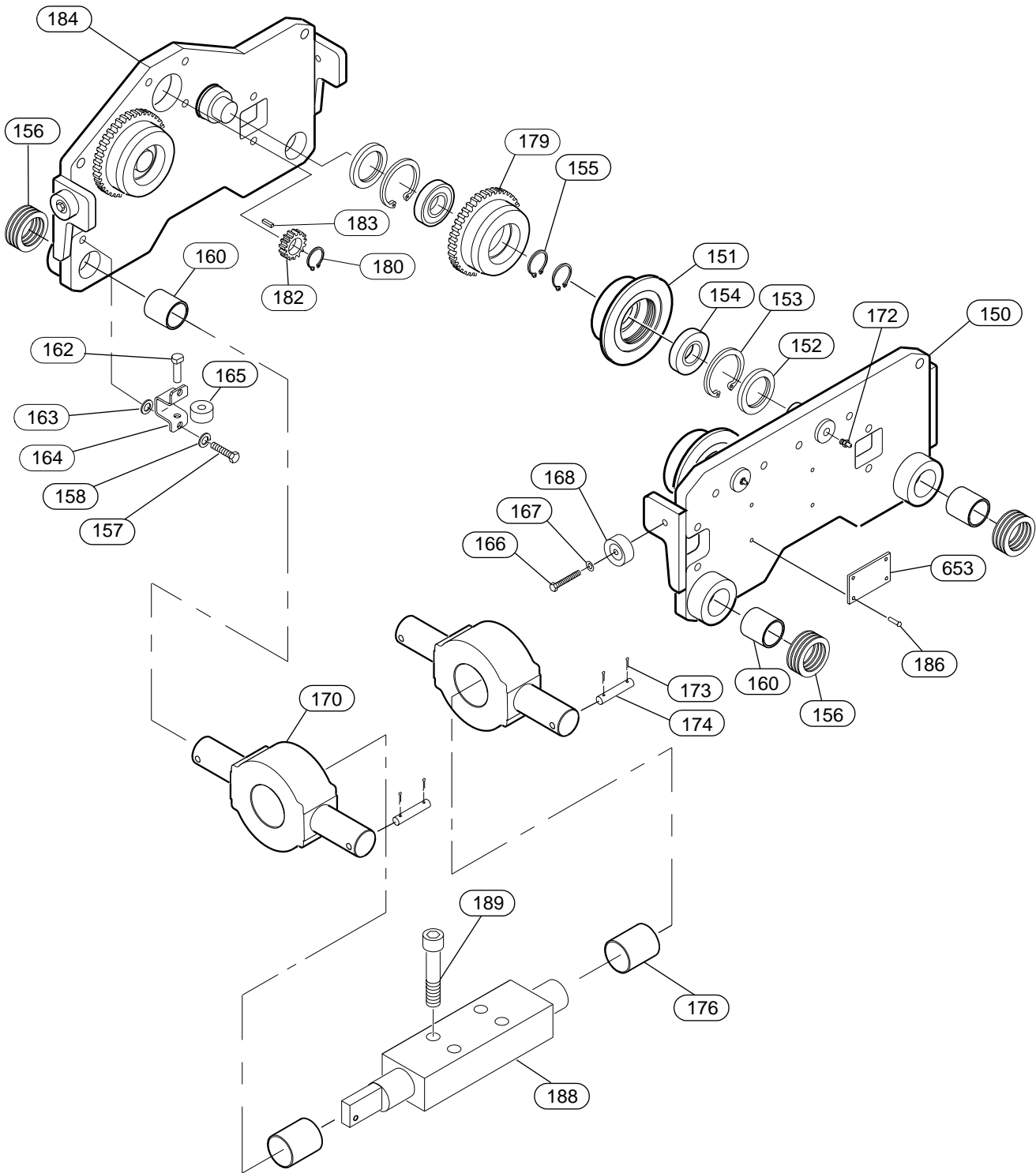

(Dwg. MHP1525)

12.5 TON TROLLEY ASSEMBLY PARTS LIST

Item No.	Description of Part	Qty Total	Part Number
150	Side Plate (Plain)	2	22898
151	Wheel (Plain)	2	8212
	Wheel (Copper Plate)		Contact Factory
	Wheel (Zinc Plate)		
	Wheel (Bronze)		
152	Oil Seal	4	50539
153	Retaining Ring	4	51069
154	Bearing	4	51066
155	Retaining Ring	4	52355
156	Spacer	36	8424-6
157	Capscrew	4	Order Kit 24111-1
158	Lockwasher		
160	Bushing	4	28476-1
162	Pin	4	Order Kit 24111-1
163	Spacer		
164	Guide Roller Holder		
165	Guide Roller		
166	Capscrew	4	53890
167	Washer	4	50177
168	Bumper	4	51722
170	Suspension Yoke (6-8 in. Std.)	2	22901
	Suspension Yoke (8-10 in.)		Contact Factory
	Suspension Yoke (10-12-½ in.)		
	Suspension Yoke (14-16 in.)		
172	Fitting, Grease	10	53095
173	Pin, Cotter	8	51996
174	Pin	4	22933
176	Bushing	2	21833
179	Geared Wheel (Plain)	1	8234
	Geared Wheel (Copper Plate)		8234-CP
	Geared Wheel (Zinc Plate)		Contact Factory
	Geared Wheel (Bronze)		8234-3
180	Retaining Ring (Piston Motor)	1	52645
	Retaining Ring (Vane Motor)		51192
182	Drive Gear	1	17690
183	Key	1	19523-075
184	Side Plate (Geared)	1	22897
186	Drive Screw	4	50915
188	Suspension Bar	1	22899
189	Capscrew	4	71124804
653	Nameplate	1	71070098-R

* Geared Trolleys require Quantity (1) Plain Side Plate.

25 TON AND LARGER TROLLEY ASSEMBLY PARTS DRAWING

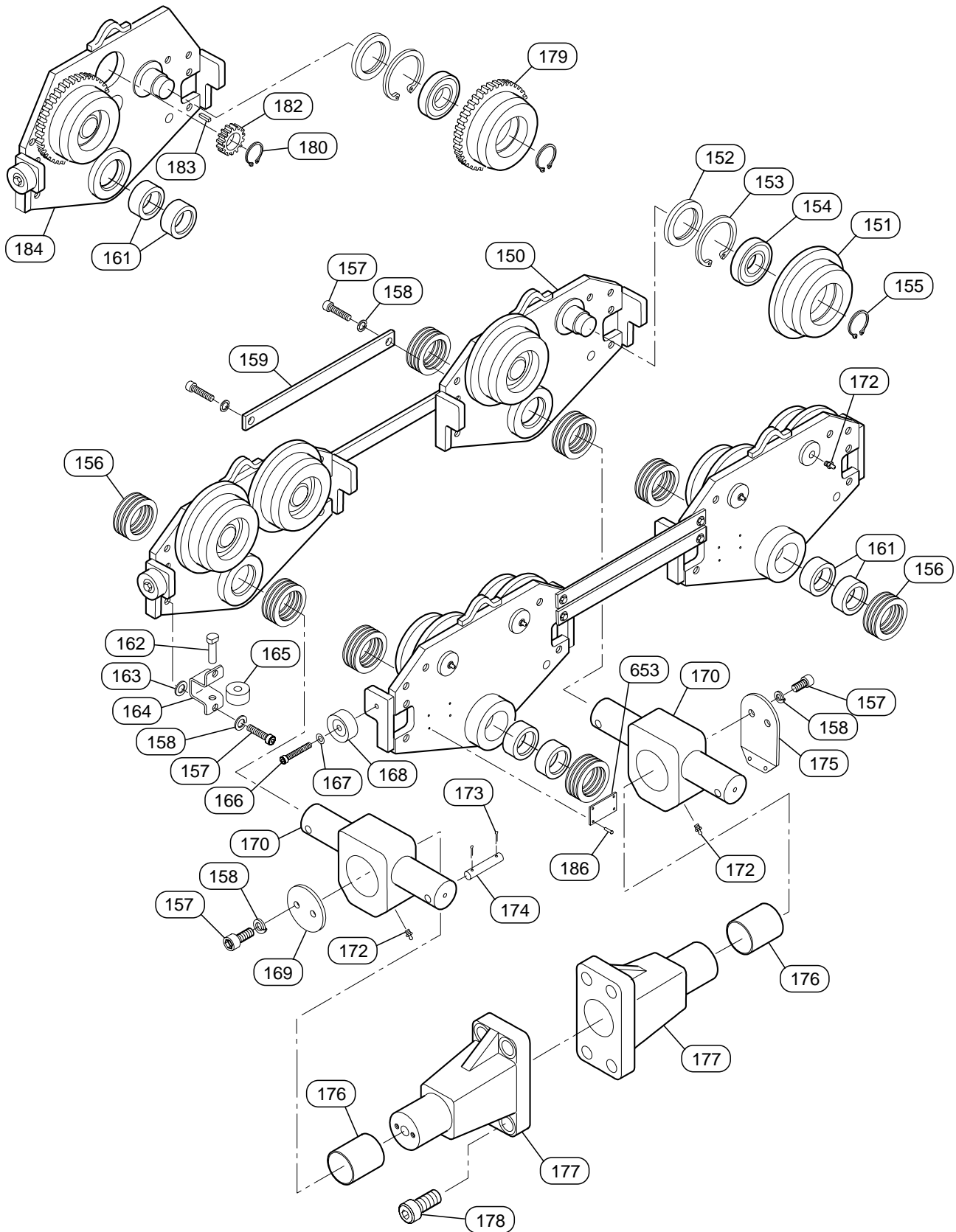

(Dwg. MHP0282)

25 TON AND LARGER TROLLEY ASSEMBLY PARTS LIST

Item No.	Description of Part	Qty Total	Part Number		
			25 Ton	37.5 Ton	50 Ton
150	Side Plate (Plain) Right Hand	See ()	8326 (3)	17525 (2)	16760 (2)
	Side Plate (Plain) Left Hand		8327 (1)	17527 (2)	16240 (2)
151	Wheel (Plain)	8*	8212	8402	
	Wheel (Copper Plate)		18485	8402-CP	
	Wheel (Zinc Plate)		18486	Contact Factory	
	Wheel (Bronze)		8212-1	Contact Factory	
152	Oil Seal	8	50539	50540	
153	Retaining Ring	8	51069	51046	
154	Bearing	8	51066	50455	
155	Retaining Ring	8	51070	51046	
156	Spacer	See ()	8424-2 (36)	8424 (20)	
157	Capscrew	20(16)	Order Kit 24111-1S	Order Kit 24111-2S	
158	Lockwasher				
159	Connecting Plate	See ()	8329-12 (4)	16402-1 (2)	
161	Bushing	8	28476-3	28476-2	
162	Pin	4	Order Kit 24111-1S	Order Kit 24111-2S	
163	Spacer				
164	Guide Roller Holder				
165	Guide Roller				
166	Capscrew	4	51712	52008	
167	Washer	4	50177	50182	
168	Bumper	4	51722	71756	
169	Cap	1	16185	16188	
170	Suspension Yoke (6-8 in. Std.)	2	16184	Contact Factory	
	Suspension Yoke (8-10 in.)		18815	18026	16166
	Suspension Yoke (10-12-½ in.)		21054	16639	
	Suspension Yoke (14-16 in.)		---	----	16166-D
172	Fitting, Grease	10	53095		
173	Pin, Cotter	8	51996	54447	
174	Pin	4	16291	16292	
175	Bracket	1	16186	17706	
176	Bushing	2	16187	16190	
177	Trolley Bracket	2	11852	17133	11854
178	Capscrew	8	71322192		
179	Geared Wheel (Plain)	2	8234	8403	
	Geared Wheel (Copper Plate)		18483	8403-CP	
	Geared Wheel (Zinc Plate)		18484	Contact Factory	
	Geared Wheel (Bronze)		8234-1	Contact Factory	
180	Retaining Ring (Piston Motor)	1	52645		
	Retaining Ring (Vane Motor)		51192		
182	Drive Gear	1	17690		
183	Key	1	19523-100		
184	Side Plate (Geared)	1	8327	17528	16650
186	Drive Screw	4	50915		
653	Nameplate	1	71070098-R		

* Geared Trolleys require Quantity (6) Plain Wheels.

TROLLEY DRIVE ASSEMBLY PARTS DRAWING

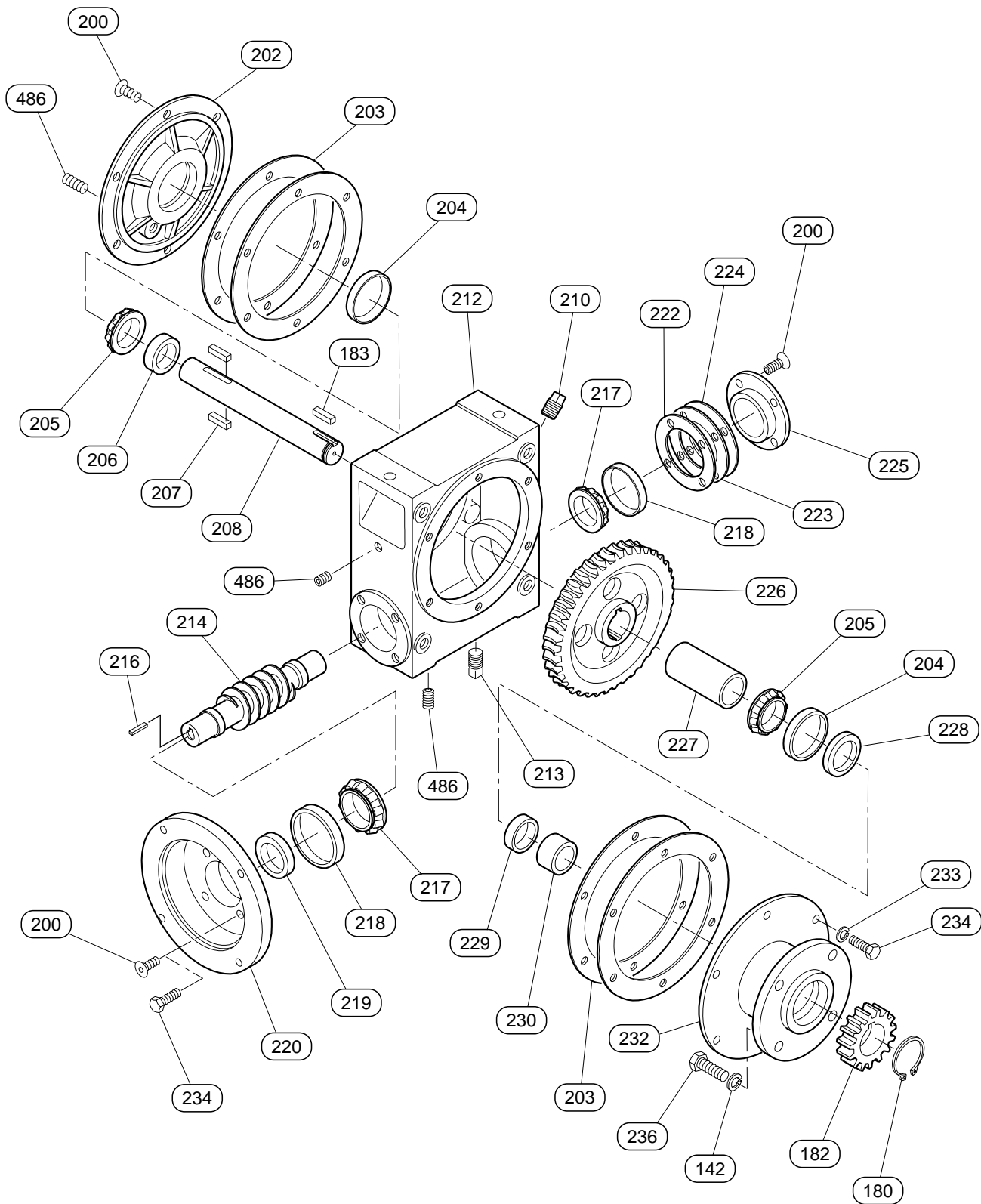

(Dwg. MHP0306)

TROLLEY DRIVE ASSEMBLY PARTS LIST

Item No.	Description of Part	Qty Total	Part Number	
			Piston Motor	Vane Motor
808	Trolley Drive Assembly	1	18798-2	17492
142	Lockwasher	4	50181	
180	Retaining Ring	1	52645	51192
182	Drive Gear**	1	17690	
183	Key (25 ton)**	1	19523-100	
	Key (37.5 and 50 ton)**		19523-075	
200	Screw	14	71328512	
202	Cover	1	3117	
203	Gasket (Set)	2	3118	
204	Bearing (Cup)	2	Order Bearing Assembly 71073407	
205	Bearing (Cone)			
206	Spacer	1	4147	
207	Key	2	3667	
208	Shaft**	1	3112-2B	
210	Plug (Vented)	1	51803	
212	Housing	1	B-5060	
213	Plug	1	52701	
214	Worm	1	11291	3829
216	Key**	1	7285-41	
217	Bearing (Cup)	2	Order Bearing Assembly 71073415	
218	Bearing (Cone)			
219	Oil Seal	1	51283	
220	Motor Adapter	1	11252	6553
222	Shim 0.007 in. (0.178 mm)	1	Order Shim Kit 6550-50	
223	Shim 0.005 in. (0.127 mm)			
224	Shim 0.020 in. (0.508 mm)			
225	Cover	1	3115	
226	Worm Gear	1	3830	
227	Spacer**	1	4147-1	
228	Oil Seal	1	51578	
229	Sleeve	1	3114	
230	Spacer**	1	4147-9	
232	Reducer Adapter**	1	8333-2	
233	Lockwasher	6	51581	
234	Capscrew	See ()	71125454 (6)	51780 (10)
236	Capscrew	4	50973	
486	Plug	3	51599	
• 807	Gear Box Service Kit incl's items 182, 183, 208, 216, 227, 230 & 232	1	9750-17	
*	Spacer Plate	1	Contact Factory	

• Recommended spare for one hoist, 2 years of normal service.

* Not illustrated **Rack drive only

TOP HOOK ASSEMBLY PARTS DRAWINGS

12-1/2 ton

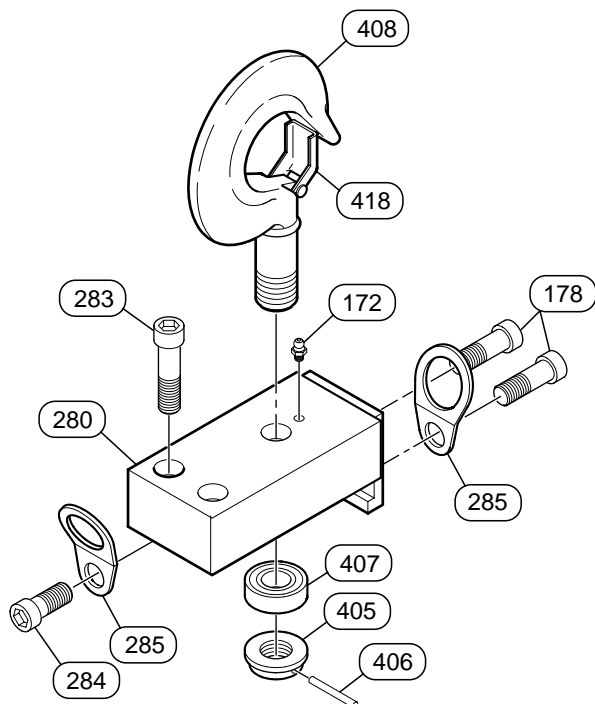

(Dwg. MHP0344)

25 ton

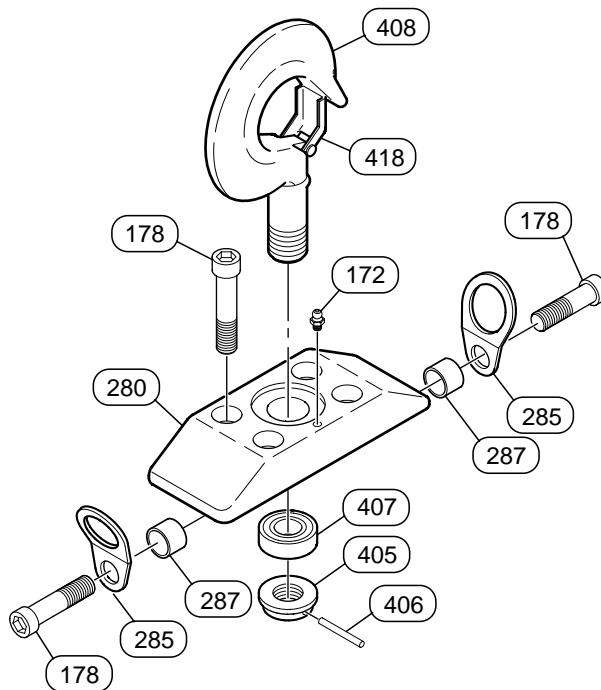

(Dwg. MHP0345)

37-1/2 ton

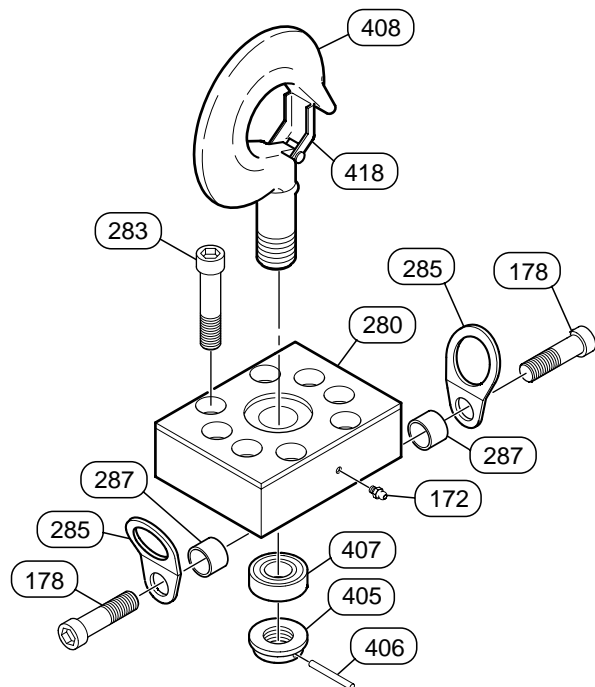

(Dwg. MHP0346)

50 ton

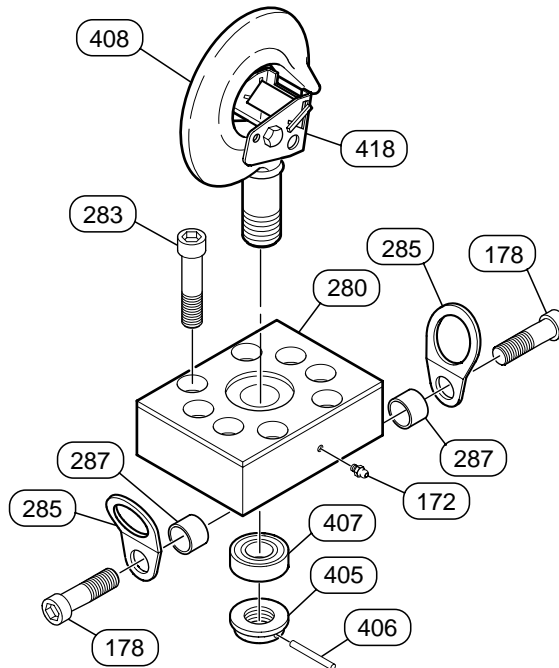

(Dwg. MHP0347)

TOP HOOK ASSEMBLY PARTS LIST

Item No.	Description of Part	Qty Total	Part Number			
			12.5 Ton	25 Ton	37.5 Ton	50 Ton
149	Top Hook Assembly	1	17896	12027	14769	14772
172	Fitting, Grease	1	53095			
178	Capscrew	See ()	71322788 (2)	71322192 (6)	71322192 (2)	
280	Hook Plate	1	17897	12058	14768	14773
283	Capscrew	See ()	71322770 (2)	---	71352090 (8)	54322 (8)
284	Capscrew	1	71322796	---		
285	Lifting Eye *	2	9575F			
287	Spacer *	2	---	16755-4		
405	Nut	1	8476	8316	8516	
406	Pin	1	50917	50958	50974	
407	Bearing	1	50144	50394	50331	
408	Hook (incl's item 418)	1	8474-3	11030	8414-3	8515-2
	Hook Copper Plate (incl's item 418)		Contact Factory	18479	8414-3-CP	Contact Factory
• 418	Hook Latch Kit	1	50597	52173	51237	50230B

- Recommended spares for one hoist, 2 years of normal service.

* Items 285 and 287 attach to Frame, item 36 or 82. Refer to Dwg. MHP0353 on page 40. Refer to Dwg. MHP0344-MHP0347 attachment capscrews.

BOTTOM BLOCK ASSEMBLY PARTS DRAWINGS

50 ton

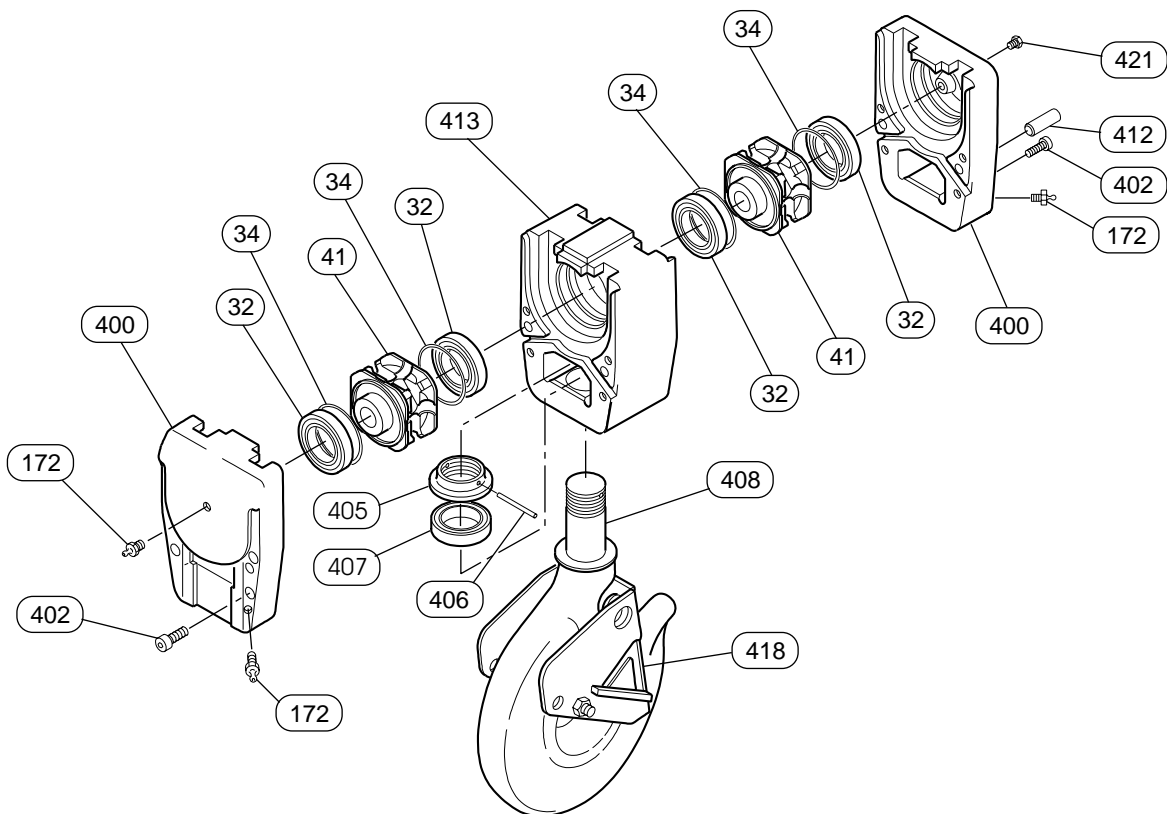

(Dwg. MHP0317)

37-1/2 ton

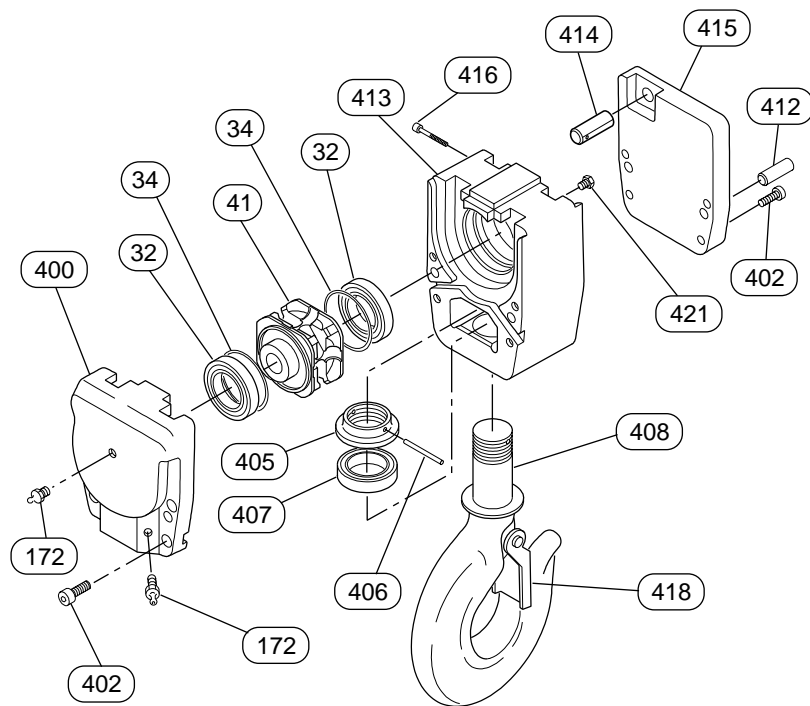

(Dwg. MHP0316)

BOTTOM BLOCK ASSEMBLY PARTS DRAWINGS AND PARTS LIST

12-1/2 ton

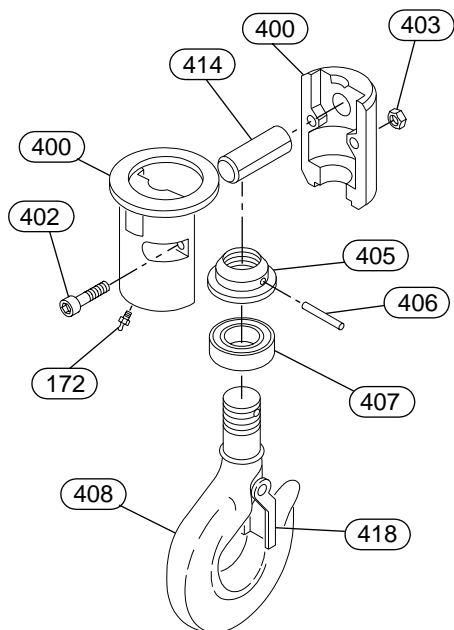

(Dwg. MHP0314)

25 ton

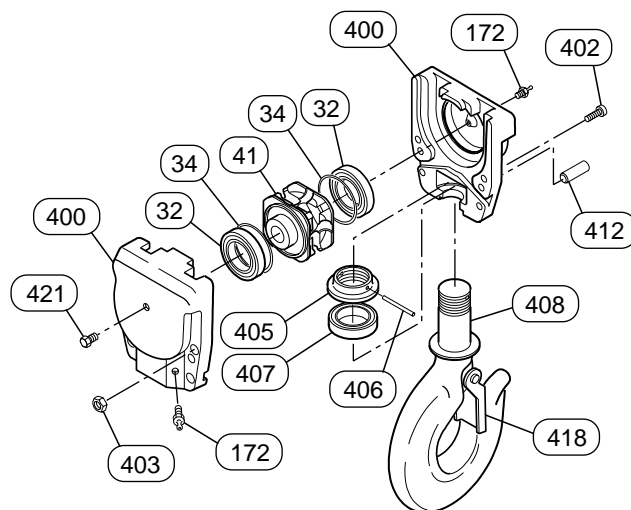

(Dwg. MHP0315)

Item No.	Description of Part	Qty Total	Part Number			
			12.5 Ton	25 Ton	37.5 Ton	50 Ton
11	Bottom Block Assembly	1	16998	12004	12928	14771
	Bottom Block Assembly (copper plate)		16998-CP	12004-2	12928-CP	Contact Factory
32	Bearing	See ()	54483 (2)			54483 (4)
34	Seal	See ()	71007405 (2)			71007405 (4)
41	Sheave, Idle	See ()	11979 (1)	11979 (1)	11979 (2)	
172	Fitting, Grease	See ()	53095 (1)	53095 (2)	53095 (2)	53095 (3)
400	Hook Block	See ()	19794 (1)	12014 (2)	12268 (1)	12267 (2)
402	Capscrew	See ()	71028559 (2)	71264675 (4)	71264675 (8)	
403	Nut	See ()	53783 (2)	51752 (4)	---	
405	Nut	1	8476	8316	8516	
406	Pin	1	50960	50958	50974	
407	Bearing	1	50144	50394	50331	
408	Hook (incl's item 418)	1	8474-3	20504	8414-3	8515-2
	Hook Copper Plate (incl's item 418)		18889-CP	18479	Contact Factory	20506
	Hook with Bullard Latch		Contact Factory	13725	Contact Factory	
412	Pin	See ()	---	54205 (2)	54205 (4)	
413	Hook Center Block	1	---		13000	12264
414	Cotter Pin	1	22280	---	22280	---
415	Side Plate	1	---		12999	
416	Capscrew	1	---		71328744	
• 418	Hook Latch Kit	1	71341663	52173	51237	50230
421	Breather	1	---	52024		

• Recommended spare for one hoist, 2 years of normal service.

CHAIN BUCKET ASSEMBLY DRAWING AND PARTS LIST

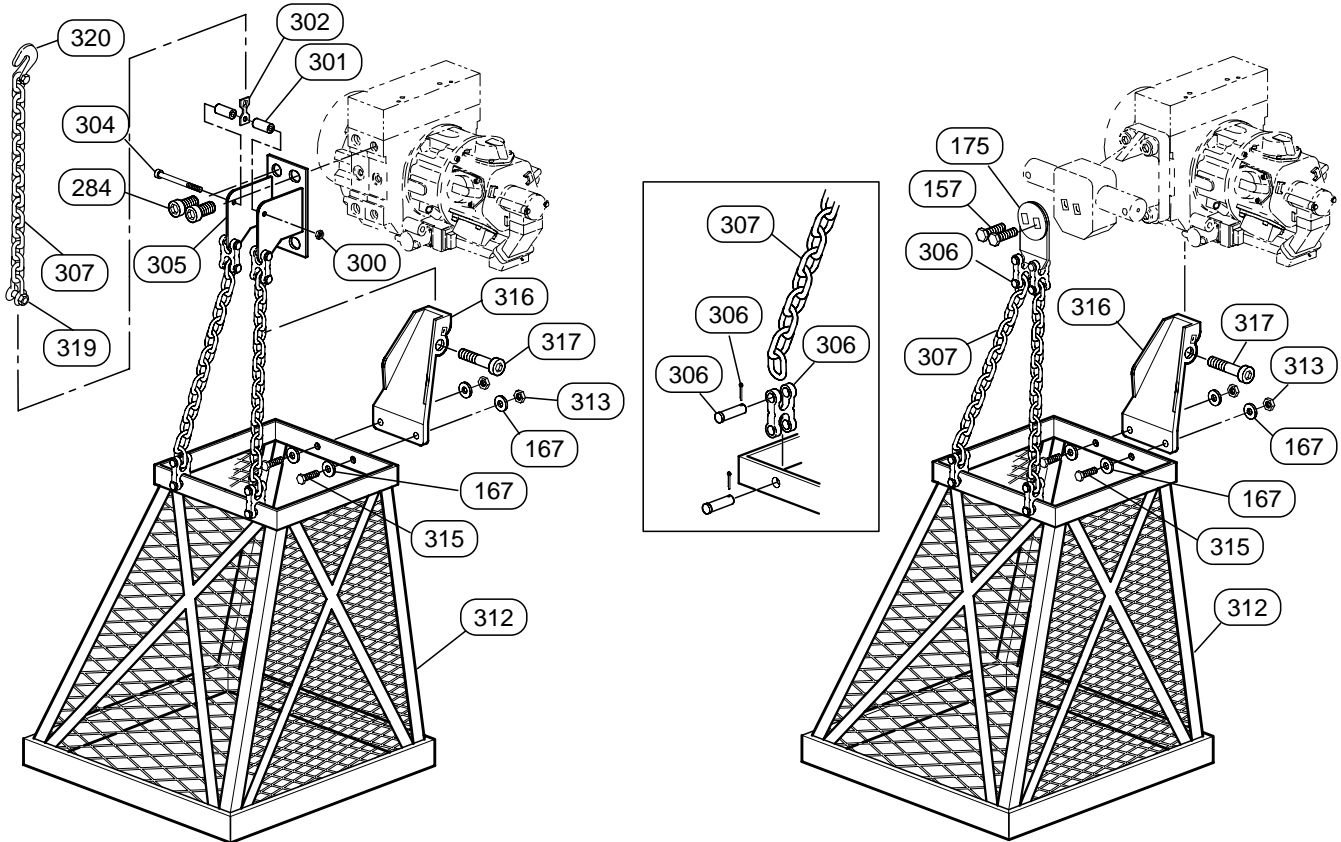

(Dwg. MHP1524)

Item No.	Description of Part	Qty Total	Part Number	Item No.	Description of Part	Qty Total	Part Number
167	Washer	4	50177	304	Capscrew	1	71098073
157	Capscrew (25 ton)	2	Order Kit 24111-18	305	Bracket	1	21619
	Capscrew (37.5 and 50 ton)			306	Clevis Assembly	4	54645
175	Bracket (25 ton)	1	161B6	307	Chain (bulk)	Specify Length	50962
	Bracket (37.5 and 50 ton)			312	Chain Bucket	1	Contact Factory
284	Capscrew	3	54727	313	Nut	2	71061584
300	Nut	1	51750	315	Capscrew	2	54240
301	Spacer	2	23435-188	316	Chain Guide	1	17575
302	Tension Link (12-1/2 ton)	2	21620	317	Capscrew	1	54202
	Tension Link (25 ton)	3		319	Shackle	1	71098099
	Tension Link (37-1/2 and 50 ton)	4		320	Hook	1	71098081

* Specify Load Chain Length in feet

LOAD CHAIN AND CHAIN STOPPER DRAWING AND PARTS LIST

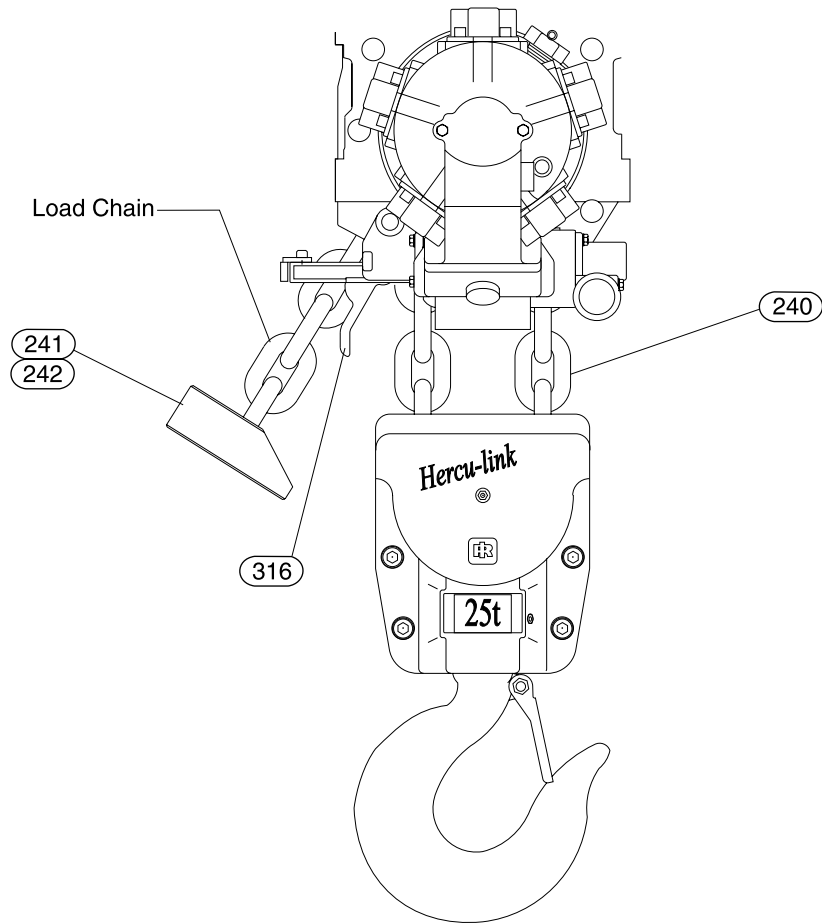

(Dwg. MHP0399)

Item No.	Description of Part	Qty Total	Part Number
240	Load Chain (Zinc Plated)	Specify Length	16756
241	Chain Stopper	1	16246
242	Capscrew	1	50956
316	Chain Guide	1	17575

HOSE ASSEMBLY DRAWING AND PARTS LIST

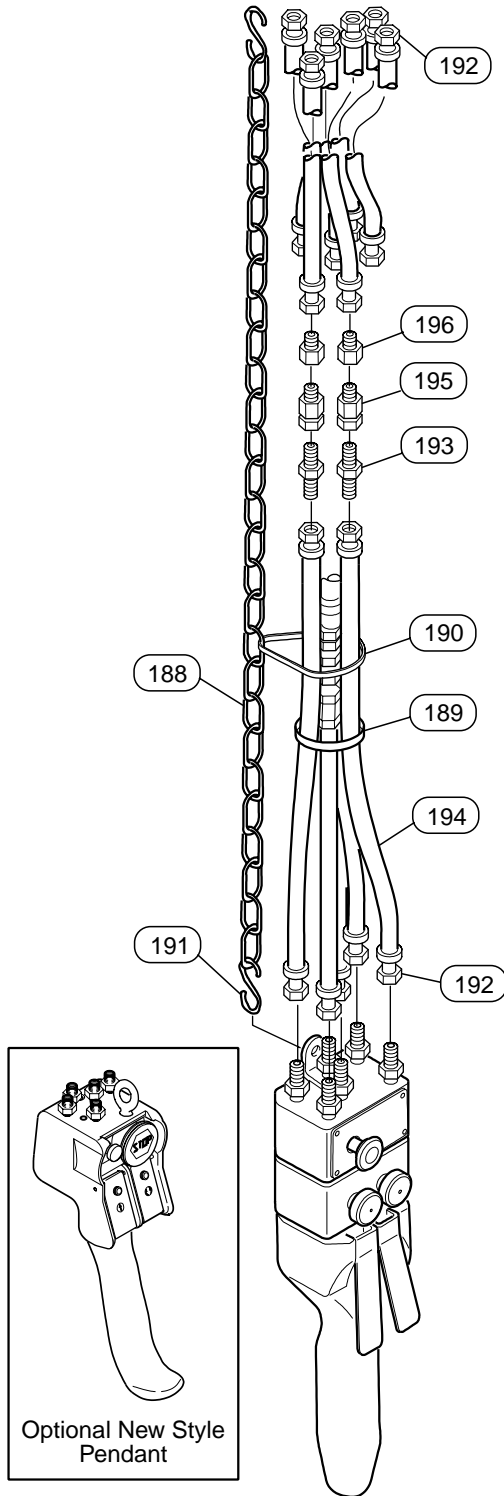

(Dwg. MHP0425)

Item No.	Description of Part	Qty Total	Part Number
188	Chain, Zinc Plated	As req'd	50041
189	Tie Wrap		54235
190	Tie Wrap		71308746
191	'S' Hook	2	D02-421
192	Hose Fitting	As req'd	51029
193	Fitting, Nipple		71048268
194	Hose (bulk)		50923
195	Exhaust Valve	As req'd	71372890
•	Exhaust Valve Kit (incl's items 192, 193 and 196)	As req'd	20417
196	Fitting	As req'd	71048284
•	Recommended spare or one hoist, 2 years of normal service.		

Hose Assembly

Pendant without Emergency Stop

Length		Part Number		
Feet	Meters	2 Lever	4 Lever	6 Lever
10	3	21653-10	21654-10	21655-10
15	4.5	21653-15	21654-15	21655-15
20	6	21653-20	21654-20	21655-20
25	7.6	21653-25	21654-25	21655-25
30	9	21653-30	21654-30	21655-30
35	10.7	21653-35	21654-35	21655-35
40	12	21653-40	21654-40	21655-40
45	13.7	21653-45	21654-45	21655-45
50	15.25	21653-50	21654-50	21655-50

Pendant with Emergency Stop

10	3	21656-10	21657-10	21658-10
15	4.5	21656-15	21657-15	21658-15
20	6	21656-20	21657-20	21658-20
25	7.6	21656-25	21657-25	21658-25
30	9	21656-30	21657-30	21658-30
35	10.7	21656-35	21657-35	21658-35
40	12	21656-40	21657-40	21658-40
45	13.7	21656-45	21657-45	21658-45
50	15.25	21656-50	21657-50	21658-50

- Notes:**
1. Dump valves included on lengths of 10 ft. (3 m) and greater.
 2. For hose bundles longer than 50 ft. (15.25 m) contact Technical Sales for control acceptability.
 3. Exhaust valve assembly not required when using new style pendants.

HULL BUMPER ASSEMBLY DRAWING AND PARTS LIST

12.5 and 25 ton Hoists

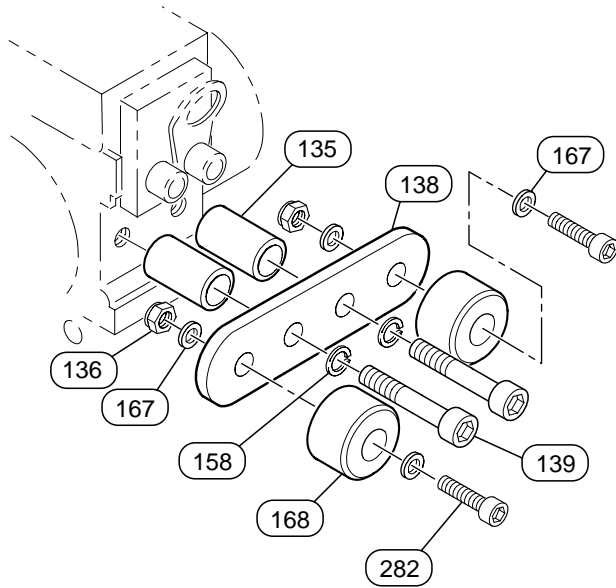

(Dwg. MHP0431)

37.5 and 50 ton Hoists

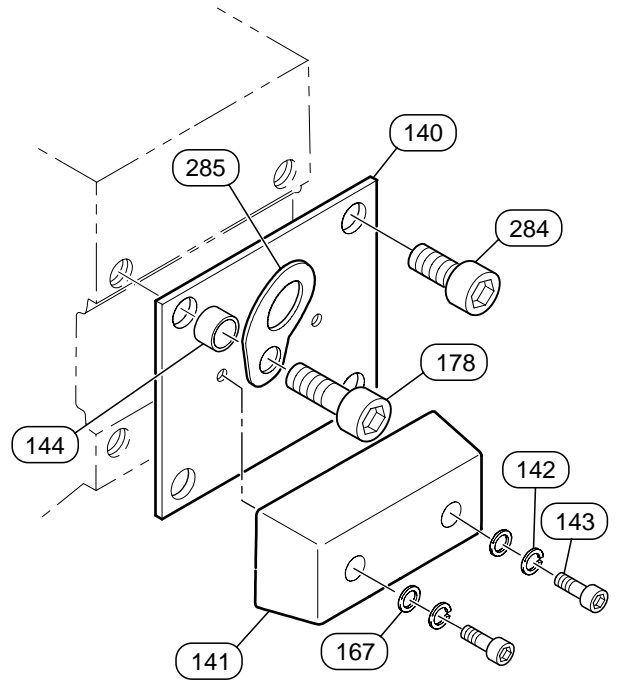

(Dwg. MHP0433)

Item No.	Description of Part	Qty Total	Part Number			
			12.5 Ton	25 Ton	37.5 Ton	50 Ton
120	Bumper Assembly	1	16178		16180	
135	Spacer	2	16640-10		---	
136	Nut	2	52919		---	
138	Bracket	1	9596-1		---	
139	Capscrew	2	53997		---	
140	Mounting Plate	1	---		19406	
141	Bumper	1	---		54739	
142	Lockwasher	2	---		50181	
143	Capscrew	2	---		54662	
144	Spacer	1	---		16755-3	
158	Lockwasher	2	50203		---	
167	Washer	4(2)	52914			
168	Bumper	2	71756		---	
178	Capscrew	1	---		54319	
282	Capscrew	2	50197		---	
284	Capscrew	3	---		54727	
285	Lifting Eye	1	---		9575F	

() Quantity required for 37.5 and 50 ton models only.

ROPE CONTROL ASSEMBLY DRAWING

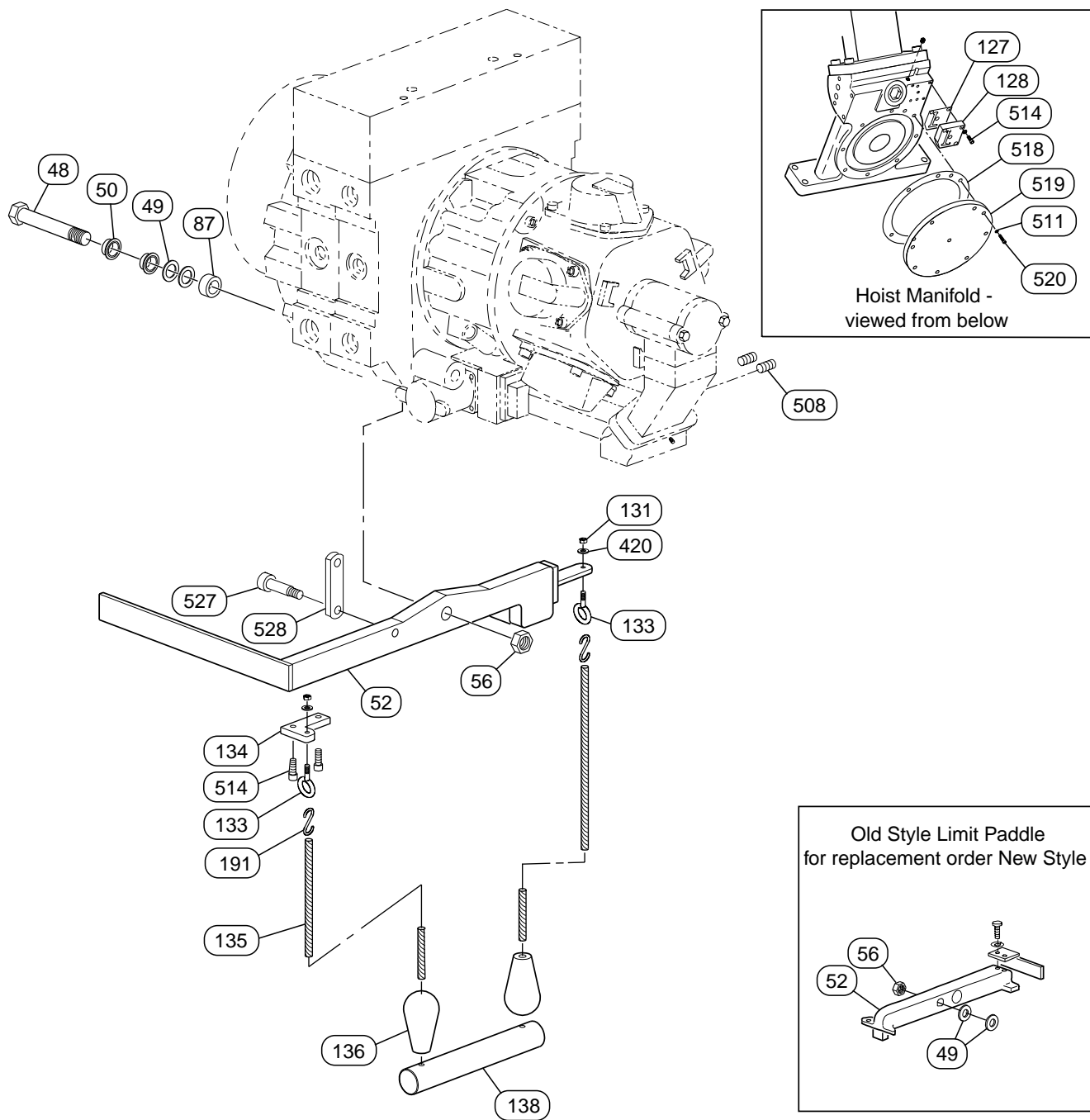

(Dwg. MHP1515)

ROPE CONTROL ASSEMBLY PARTS LIST

Item No.	Description of Part	Qty Total	Part Number
125	Rope Control Assembly (incl's items 127-134, 191, 420, 508 and 514)	1	14874
48	Capscrew	1	71322143
49	Washer	2	52915
50	Bushing	2	52675
52	Limit Arm Assembly (includes items, 49-50, 55-56, 84-85 for 12-1/2 and 25 ton)	1	16219
	Limit Arm Assembly (includes items, 49-50, 55-56, 84-85 for 37-1/2 and 50 ton)		17290
56	Nut	1	54661
87	Spacer	1	23431-046
126	Plug, Vented	1	14895
127	Gasket	1	21555
128	Cover Plate	1	14879
131	Nut	2	50852
133	Eyebolt	2	54753
134	Rope Control Arm	1	21199
135	Nylon Cord	As req'd	51777
136	Knob	2	4868
138	Control Handle	1	8273
191	'S' Hook	2	52120
420	Washer	2	51676
508	Plug	3	54247
511	Lockwasher	8	71268890
514	Capscrew	6	51939
518	Gasket	1	9857
519	Cover Plate	1	20250
520	Capscrew	9	50851
527	Shoulder Bolt	1	71085179
528	Link	1	21289

TROLLEY MOUNT PIPING ASSEMBLY PARTS DRAWING

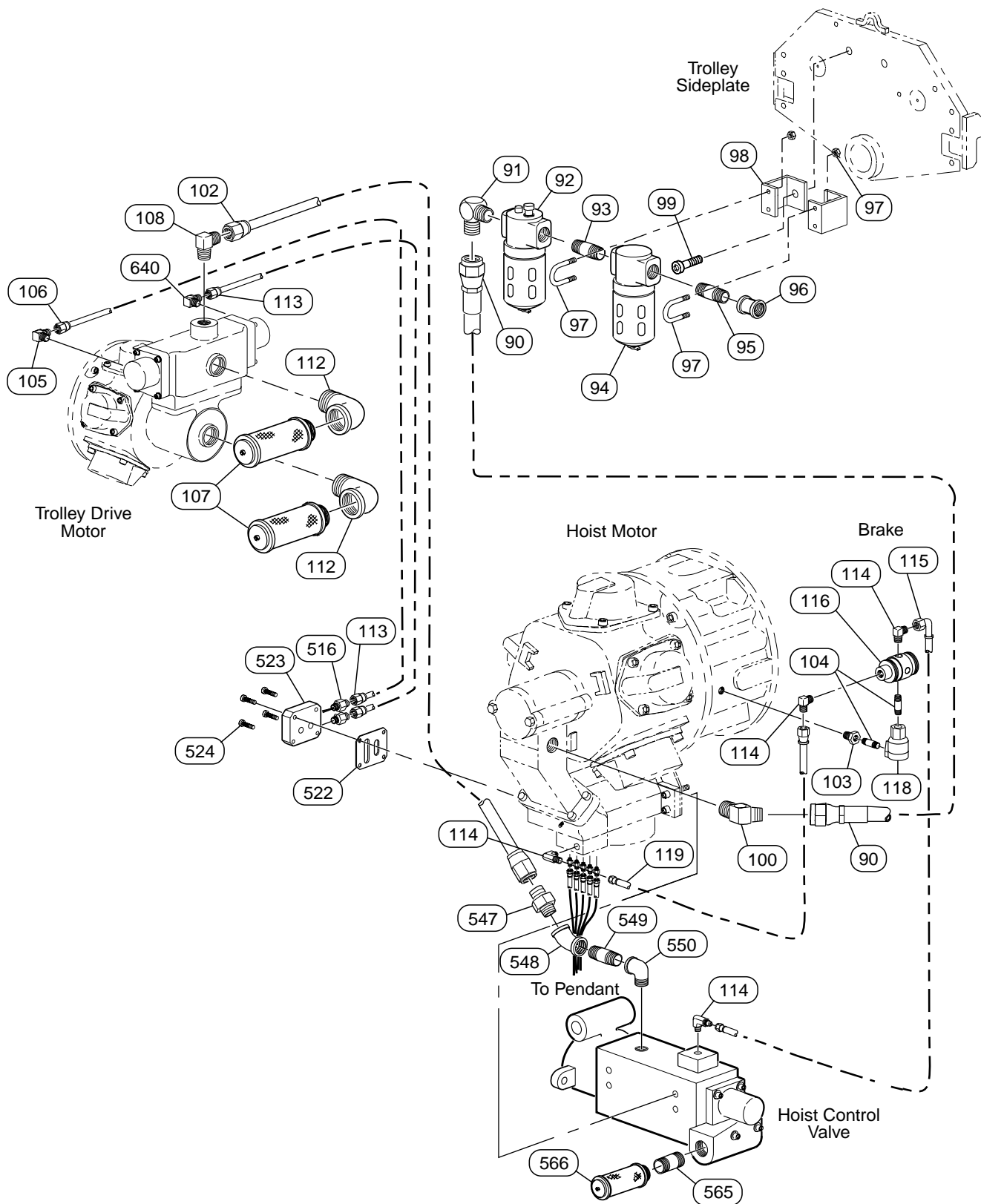

(Dwg. MHP1514)

TROLLEY MOUNT PIPING ASSEMBLY PARTS LIST

Item No.	Description of Part	Qty Total	Part Number	
			Without E-Stop	With E-Stop
90	Hose Assembly	1	---	17550-1
91	Fitting, Elbow	1	54244	54259
92	Lubricator (optional)	1	L30-08-000	
93	Fitting, Nipple	1	---	51018
94	Filter (optional)	1	F30-08-000	
95	Fitting, Nipple	2(1)	71077093	54267
96	Fitting, Coupling	1	52318	
97	'U'-Bolt (with Nut)	1(2)	51681	
98	Bracket	1(2)	14878	8551-5
99	Capscrew	1(2)	50856	
100	Fitting, Elbow	1	---	53030
102	Hose Assembly	1	---	17549-1 or -2
103	Fitting, Reducer	1	54870	
104	Fitting, Nipple	1(2)	52191	
105	Fitting, Elbow	2	---	52182
106	Hose Assembly	1	---	17073-3
107	Muffler 3/4 in.	2	---	52104
108	Fitting, Elbow	1	---	53462
112	Fitting, Elbow	2	---	71108781
113	Hose Assembly	1	---	17073-4
114	Fitting, Elbow	4	51281	
115	Hose Assembly	1	17073-1	
116	Valve	1	---	51756
118	Dump Valve	1	50275	
119	Hose Assembly	1	17073-2	
516	Fitting	2	---	52092
522	Gasket	1	9856	
523	Manifold (Trolley)	1	9439	
547	Fitting, Nipple	1	---	54623
548	Fitting, Elbow	1	---	54624
549	Fitting, Nipple	1	---	52809
550	Fitting, Elbow	1	---	54611
565	Fitting, Nipple	1	---	51704
566	Muffler 1-1/4 in.	1	52465	
640	Fitting, Elbow	1	53029	---

HOOK-MOUNT LUBRICATOR-FILTER PIPING ASSEMBLY

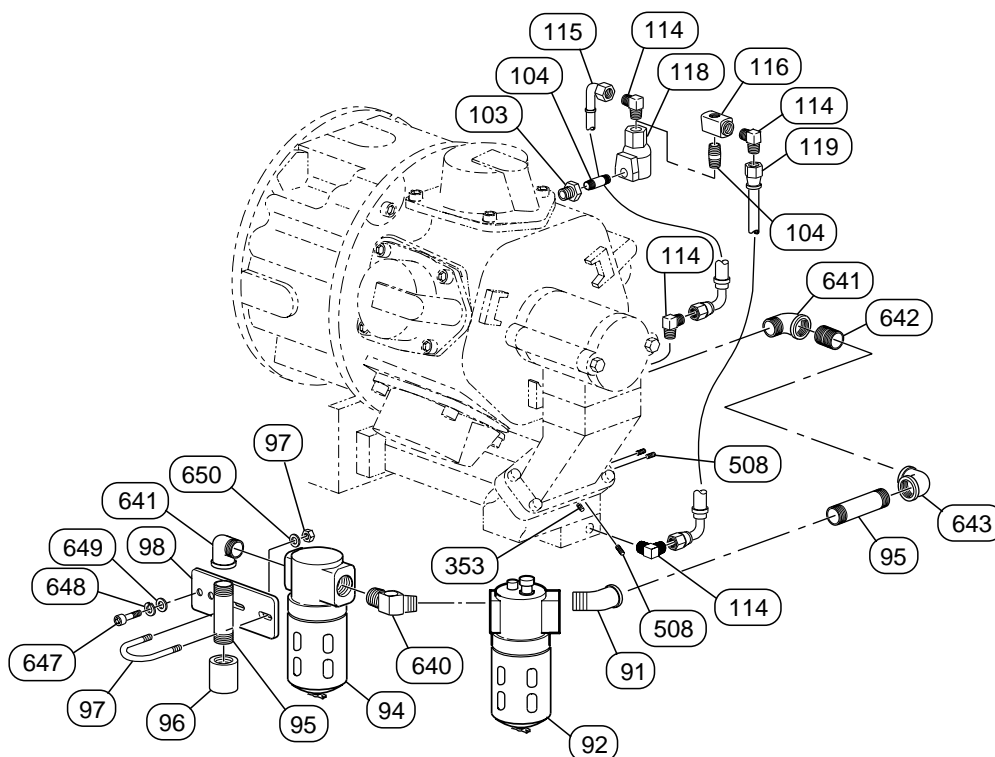

(Dwg. MHP0601)

Item No.	Description of Part	Qty Total	Part Number	
			With Emergency Stop	Without Emergency Stop
91	Fitting, Elbow	2	54243	
92	Lubricator (Optional)	1	L30-08-000	
94	Filter (Optional)	1	F30-08-000	
95	Fitting, Nipple	2	71077093	
96	Fitting, Coupling	1	52318	
97	'U' Bolt (w/ Nut)	1	51681	
98	Bracket	1	14878	
103	Fitting, Reducer	1	54870	
104	Fitting, Nipple	See ()	52191 (1)	52191 (2)
114	Fitting, Elbow	See ()	51281 (2)	51281 (4)
115	Hose Assembly	1	17073-1	17073-2
116	Valve	1	---	51756
118	Dump Valve	1	50275	
119	Hose assembly	1	17073-2	
333	Plug	1	54658	---
508	Plug	3	54247	
640	Fitting, Elbow	1	53029	
641				
642	Fitting, Nipple	1	50933	
643	Fitting, Elbow	1	50928	
647	Capscrew	2	52982	
648	Lockwasher	2	51801	
649	Washer	2	53540	
650	Washer	2	53516	

MUFFLERS DRAWING AND PARTS LIST

Hoist Motor

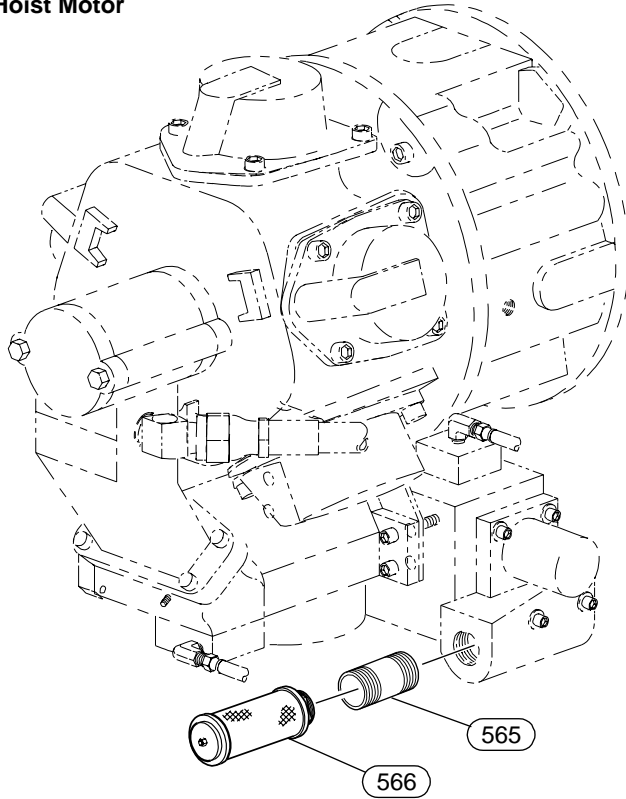

Trolley Motor

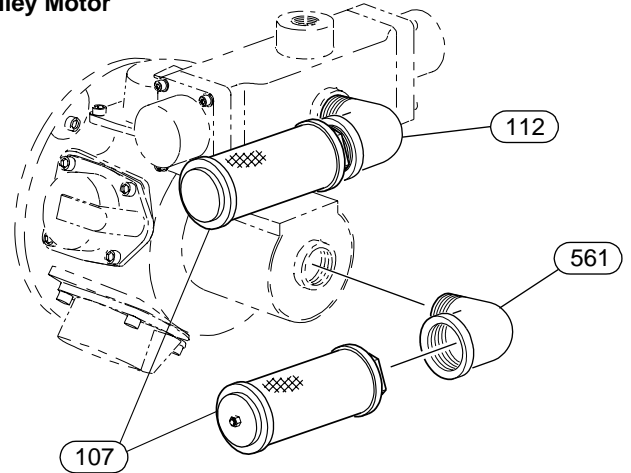

(Dwg. MHP1526)

Item No.	Description of Part	Qty Total	Part Number
107	Muffler, 3/4 in.	2	52104
112	Fitting, Elbow	1	71108781
561	Fitting, Elbow	1	52190
565	Fitting, Nipple	1	51704
566	Muffler, 1-1/4 in.	1	52465

LABEL AND TAG PARTS LIST

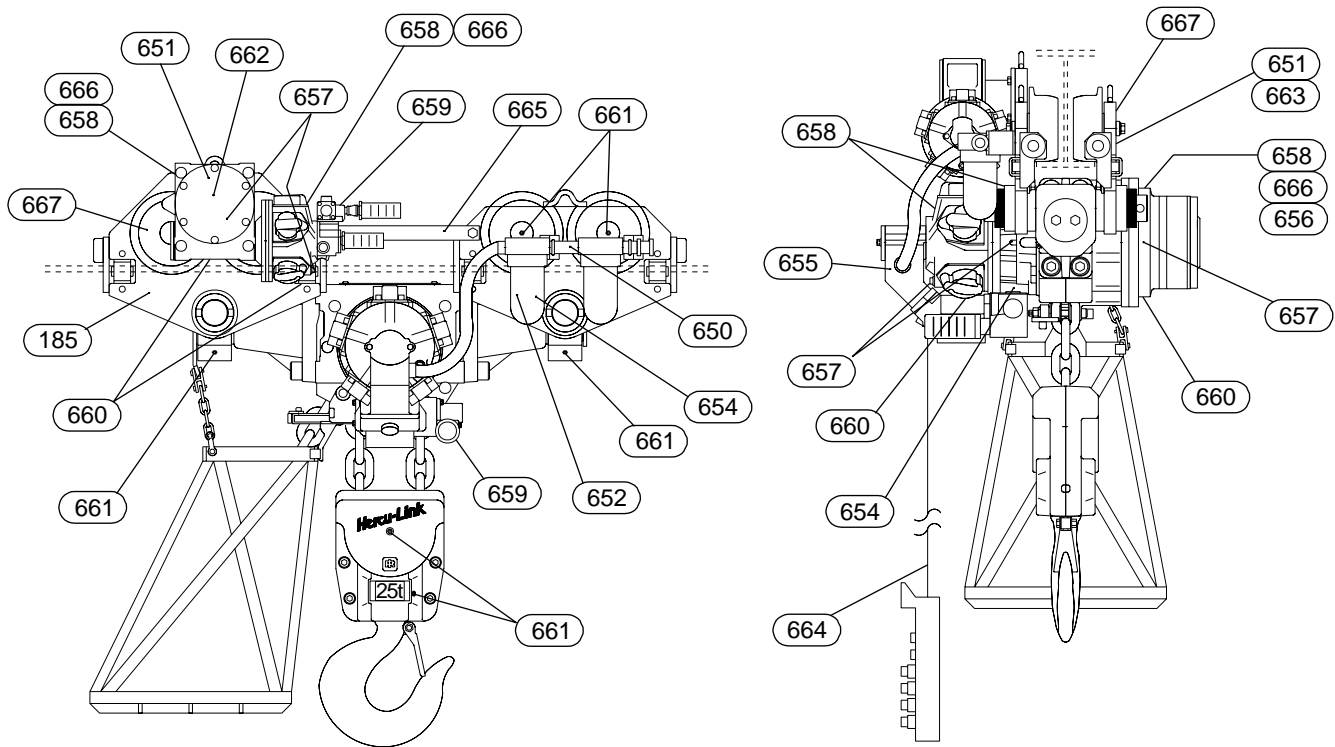

Note: Exact location of Tags and Labels may vary, depending on unit configuration, options and accessories.

(Dwg. MHP1496)

Item No.	Description of Part	Qty Total		Part Number
		Hook Mount	Trolley Mount	
---	Label Kit (Hook Mounted Hoist)	As req'd	---	18916-R
---	Label Kit (Trolley Mounted Hoist)	---	As req'd	18917-R
185				
650	Tag, Supply Line Notice		1	71042121
651	Label, Hercul-Link Logo	2	3	71046387
652	Tag, Oil Fill Notice		1	71042147
653	Nameplate		1	71070098-R
654	Label, "Drain"		2	71043632
655	Label, "Air Supply"		1	71046395
656	Tag, Oil Level Caution	1	3	71107148
657	Label, "Oil Level"	4	6	71043616
658	Label, "Oil Fill"	3	5	71042204
659	Label, "Exhaust"	1	3	71042196
660	Label, "Oil Drain"	3	5	71042188
661	Label, "Lube"	5	13	71042170
662	Label, Ingersoll-Rand Name and Logo	2	1	71106231
663	Label, Ingersoll-Rand Name and Logo	---	2	71106256
664	Tag, Operating Warning		1	71059612
665	Label, May be Removed after Installation	---	12-1/2 Ton - 0 25 Ton - 4 37-1/2 Ton - 2	71042154
666	Tag, Vent Plug Notice	2	---	71107155
667	Label, Operating Warning	1	2	71107130

ACCESSORIES AND REPAIR KITS

Description of Part	Qty Total	Part Number
Air Supply Hose (Bulk) 1-1/4 in.	Specify Length	50766
Chain Lubricant	As req'd	LUBRI-LINK-GREEN®
Control Valve (item 800) Service Kit	1	71034573
Filter (1 in. FNPT)	1	F30-08-000
Hoist Piston Motor (item 450) Service Kit (incl's items 452, 454, 458, 460 and 470)	1	71032932
Label Kit (Hook Mount Hoist)	1	18916-R
Label Kit (Trolley Mount Hoist)	1	18917-R
Liquidator	1	8848-LU1-150
Lubricator (1 in. FNPT)	1	L30-08-000
Manifold Seal Kit (incl's items -)	1	71034599
Old Style Pendant Assembly Service Kit	1	9750-4
Regulator (1 in. FNPT)	1	R30-08-000
Regulator Gauge	1	GRP-95-229
Flat Gear Rack Section (6 ft.)	1	10953
Strainer	1	JU-A267AT
Trolley Control Valve (item 804) Service Kit	1	9750-13
Trolley Drive Vane Motor Repair Kit (incl's items 251, 252, 254, 255, 258, 262, 264 and 265)	1	1000P60-VMK
Trolley Gearbox Service Kit (incl's items 182, 183, 208, 216, 227, 230 and 232)	1	9750-17
Trolley Piston Motor Repair Kit (incl's items 330, 331, 358, 368, 370, 372 and 374)	1	71028120

HOIST UPGRADES

The brake piston and seal design on all HA2 hoists were revised as part of **Ingersoll-Rand's** continuing product improvement program. Refer to Table 10 for description of change.

When replacing brake piston on hoists with serial numbers prior to HL0510992 (approximate manufacture date Sept. 1992) order retrofit kit part number 22181.

Table 10—Brake Upgrade Parts List

Old Parts		New Parts	
Description of Part	Part No.	Description of Part	Part No.
'O' Ring	52672	Seal	71107726
'O' Ring	52671	Seal	71107718
Brake Piston	11949	Brake Piston	22177

NOTICE

• Parts are not interchangeable. 'O' rings cannot be used with new brake piston and seals cannot be used with old brake piston.

PARTS ORDERING INFORMATION

Hercu-Link hoists are designed and constructed to provide long, trouble-free service. In time it may become necessary to order and install new parts to replace those that have been subjected to wear.

The use of replacement parts other than **Ingersoll-Rand** may result in decreased hoist performance, and may, at the company's option invalidate the warranty.

For your convenience and future reference it is recommended that the following information be recorded.

Model Number _____

Serial Number _____

Date Purchased _____

When ordering replacement parts, please specify the following:

1. Complete hoist model number as it appears on the nameplate.
2. Part number(s) and part description as shown in this manual.
3. Quantity required.

On hook-mounted hoists, the model and serial number plate is located on the top hook block.

On trolley-mounted hoists, the model and serial number plate is located on the trolley side plate.

NOTICE

• **Continuing improvement and advancement of design may produce changes to this hoist which are not included in this manual. Manuals are periodically revised to incorporate changes. Always check the manual edition number on the front cover for the latest issue.**

Return Goods Policy

If it becomes necessary to return the complete hoist or certain parts to the factory, contact the Distributor from whom you purchased the hoist, or the nearest **Ingersoll-Rand** Distributor in your locality. **Ingersoll-Rand** will not accept any returned goods for warranty or service work unless prior arrangements have been made and written authorization has been provided from the location where the goods were purchased.

Disposal

When the life of the hoist has expired, it is recommended that the hoist be disassembled, degreased and parts separated as to materials so that they may be recycled.

NOTICE

• **Mineral-based oils can be recycled, however, some oils such as glycols may be extremely toxic and must be identified and disposed of in accordance with local, state and national regulations.**

For additional information contact:

Ingersoll-Rand
 P.O. Box 24046
 2724 Sixth Avenue South
 Seattle, WA 98124-0046 USA
 Phone: (206) 624-0466
 Fax: (206) 624-6265

or

Ingersoll-Rand
Douai Operations
 111, avenue Roger Salengro
 59450 Sin Le Noble, France
 Phone: (33) 3-27-93-08-08
 Fax: (33) 3-27-93-08-00

For additional information on the following products order the publication by the reference Part/Document number listed:

Publication	Part/Document Number
Accu-trol Manual Supplement	MHD56014

Limited Warranty

Ingersoll-Rand Company (I-R) warrants to the original user its Hoists and Winches (Products) to be free of defects in material and workmanship for a period of one year from the date of purchase.

I-R will repair, without cost, any Product found to be defective, including parts and labor charges, or at its option, will replace such Products or refund the purchase price, less a reasonable allowance for depreciation, in exchange for the Product. Repairs or replacements are warranted for the remainder of the original warranty period.

If any Product proves defective within its original one year warranty period, it should be returned to any Authorized Hoist and Winch Service Distributor, transportation prepaid with proof of purchase or warranty card.

This warranty does not apply to Products which **I-R** has determined to have been misused or abused, improperly

maintained by the user, or where the malfunction or defect can be attributed to the use of non-genuine **I-R** parts.

I-R makes no other warranty, and all implied warranties including any warranty of merchantability or fitness for a particular purpose are limited to the duration of the expressed warranty period as set forth above. **I-R's** maximum liability is limited to the purchase price of the Product and in no event shall **I-R** be liable for any consequential, indirect, incidental, or special damages of any nature rising from the sale or use of the Product, whether based on contract, tort, or otherwise.

Note: Some states do not allow limitations on incidental or consequential damages or how long an implied warranty lasts so that the above limitations may not apply to you.

This warranty gives you specific legal rights and you may also have other rights which may vary from state to state.

Important Notice

It is our policy to promote safe delivery of all orders.

This shipment has been thoroughly checked, packed and inspected before leaving our plant and receipt for it in good condition has been received from the carrier. Any loss or damage which occurs to this shipment while en route is not due to any action or conduct of the manufacturer.

Visible Loss or Damage

If any of the goods called for on the bill of lading or express receipt are damaged or the quantity is short, do not accept them until the freight or express agent makes an appropriate notation on your freight bill or express receipt.

Concealed Loss or Damage

When a shipment has been delivered to you in apparent good condition, but upon opening the crate or container, loss or damage has taken place while in transit, notify the carrier's agent immediately.

Damage Claims

You must file claims for damage with the carrier. It is the transportation company's responsibility to reimburse you for repair or replacement of goods damaged in shipment. Claims for loss or damage in shipment must not be deducted from the **Ingersoll-Rand** invoice, nor should payment of **Ingersoll-Rand** invoice be withheld awaiting adjustment of such claims as the carrier guarantees safe delivery.

You may return products damaged in shipment to us for repair, which services will be for your account and form your basis for claim against the carrier.

United States Office Locations

For Order Entry, Order Status and Technical Support

Ingersoll-Rand

P.O. Box 24046
2724 Sixth Avenue South
Seattle, WA 98124-0046 USA
Phone: (206) 624-0466
Fax: (206) 624-6265

Ingersoll-Rand Distribution Center

P.O. Box 618
510 Hester Drive
White House, TN 37188
Phone: (615) 672-0321
Fax: (615) 672-0801

Web Site:

www.irco.com

Regional Sales Offices

Chicago, IL

131 W. Diversey Avenue
Elmhurst, IL 60126-1102
Phone: (630) 530-3800
Fax: (630) 530-3891

Detroit, MI

1872 Enterprise Drive
Rochester, MI 48309
Phone: (248) 293-5700
Fax: (248) 293-5800

Houston, TX

450 Gears Road
Suite 210
Houston, TX 77067-4516
Phone: (281) 872-6800
Fax: (281) 872-6807

Los Angeles, CA

13107 Lakeland Road
Santa Fe Springs, CA 90670
Phone: (562) 777-0808
Fax: (562) 777-0818

Philadelphia, PA

P.O. Box 425
900 E. 8th Ave., Suite 103
King of Prussia, PA 19406
Phone: (610) 337-5930
Fax: (610) 337-5912

International Office Locations

Offices and distributors in principal cities throughout the world. Contact the nearest **Ingersoll-Rand** office for the name and address of the distributor in your country or write/fax to:

Canada

National Sales Office Regional Warehouse Toronto, Ontario

51 Worcester Road
Rexdale, Ontario
M9W 4K2
Phone: (416) 213-4500
Fax: (416) 213-4510
Order Desk
Fax: (416) 213-4506

Regional Sales Offices

Edmonton, Alberta

Phone: (780) 438-5039
Fax: (780) 430-4300

Montreal, Quebec

3501 St. Charles Blvd.
Kirkland, Quebec
H9H 4S3
Phone: (514) 695-9040
Fax: (514) 695-0963

British Columbia

1200 Cliveden Avenue
Delta, B. C.
V3M 6G4
Phone: (604) 523-0803
Fax: (604) 523-0801

Latin America Operations

Ingersoll-Rand Production Equipment Group

730 N.W. 107 Avenue
Suite 300, Miami, FL
33172-3107 USA
Phone: (305) 559-0500
Fax: (305) 222-0864

Europe, Middle East and Africa

Ingersoll-Rand Douai Operations

111, avenue Roger Salengro
59450 Sin Le Noble, France
Phone: (33) 3-27-93-08-08
Fax: (33) 3-27-93-08-00

Asia Pacific Operations

Ingersoll-Rand

42 Benoi Road
Jurong, Singapore 629903
Phone: 65-861-1555
Fax: 65-861-0317

Russia

Ingersoll-Rand

Kuznetsky Most 21/5
Entrance 3
Moscow 103895 Russia
Phone: 7-501-923-91-34
Fax: 7-501-924-46-25

Australia

Ingersoll-Rand

1 Hartnett Drive
Seaford, Vic 3198
Australia
Phone: 613 95541642
Fax: 613 95541607