

IMPORTANT INFORMATION:

- A copy of our “Safe Operating Practices” Manuals are always available free of charge either by downloading it from our Technical Publications website @ www.airwinch.com or by contacting the Factory at (800) 866-5457 for North America and (206) 624-0466 for International. The Safe Operating Practices manual must be read prior to anyone operating a **Ingersoll-Rand** winch or hoist. The manual form numbers are as follows:

“Safe Operating Practices Non-Man Rider™ Winches” Manual, Form No. MHD56250

“Safe Operating Practices for Man Rider™ Winches” Manual, Form No. MHD56251

“Safe Operating Practices for Pneumatic, Hydraulic and Electric Hoists” Manual, Form No. MHD56295

- Available winch options may require additional supplements to the basic winch manual.
- For Man Rider™ winches ensure a copy of the Man Rider™ supplement is made available to the operator prior to winch operation.

Winch Man Rider™ Supplements:

Model:	Publication No.
FA2, FA2.5, FH2, FH2.5	MHD56046
FA5	MHD56042 and MHD56220
FA10	MHD56252
FA2.5A	MHD56236
FA2B and HU40A	MHD56207
FH10MR	MHD56212
Fulcrum Electric	MHD56277
LS500HLP/ LS1000HLP	SAM0004

Model:	Publication No.
LS500RLP	SAM0011
LS1000RLP	SAM0012
LS150RLP	SAM0082
LS150RLP/500/ 1000	SAM0115
LS150RLP and LS150PLP-PH	SAM0120
LS500RLP-E	SAM0122
LS150RLP- DP5M-F	SAM0184
LS150HLP	SAM0222

- We strongly recommend that ALL maintenance on **Ingersoll-Rand** equipment be carried out by personnel certified by **Ingersoll-Rand**, or by **Ingersoll-Rand** Authorized Service Centers.
- Contact the Factory if in doubt about installation, operation, inspection and maintenance instructions.
- Use only Genuine **Ingersoll-Rand** parts when maintaining or repairing a winch, hoist or any component of a winch or hoist.
- ANSI / ASME recommends that a winch or hoist (or any components of a winch or hoist) that has been repaired be tested prior to being placed into service:
 - * **Winches** - ANSI / ASME B30.7 (BASE MOUNTED DRUM HOISTS) Refer to section 7.2.2 - Testing.
 - * **Hoists** - ANSI / ASME B30.16 (OVERHEAD HOISTS - UNDERHUNG) Refer to section 16.2.2 - Testing.

LIFTSTAR™ 300 R

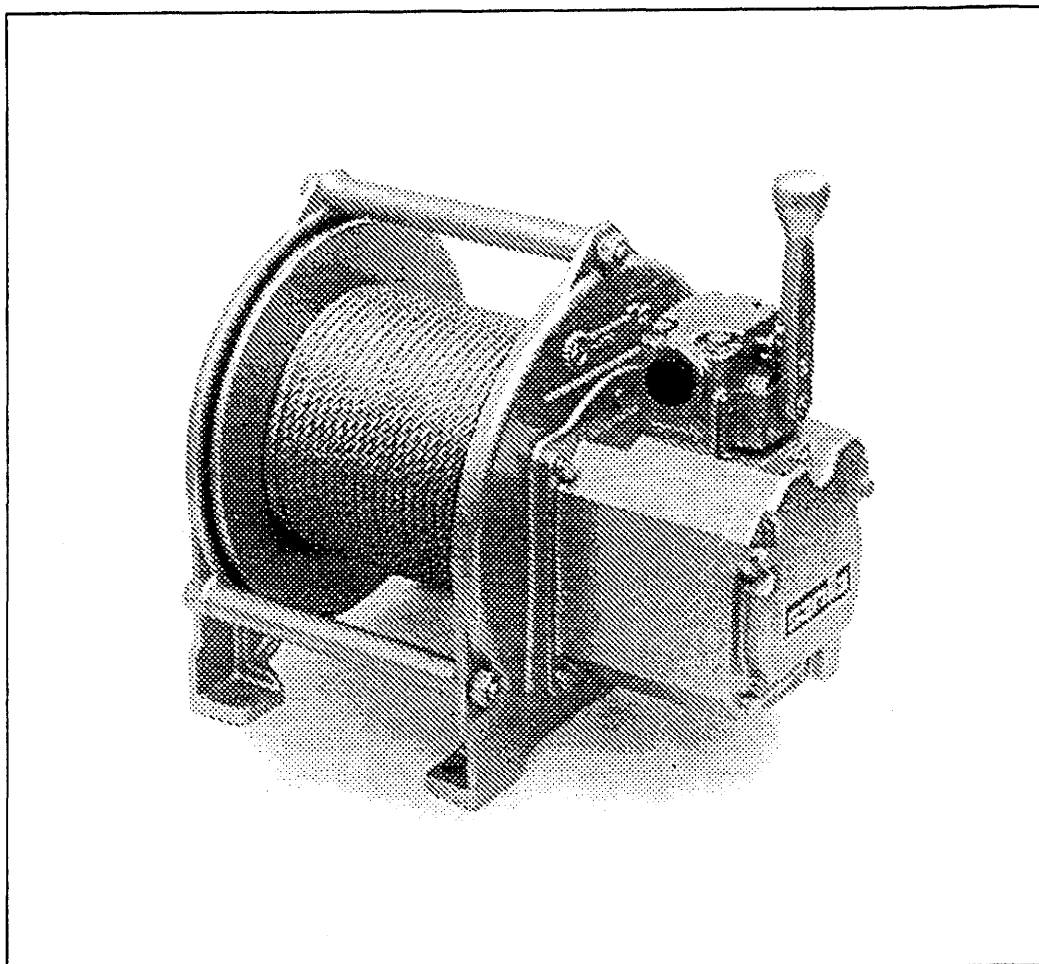

Instructions handbook

INGERSOLL-RAND®
PRODUCTION EQUIPMENT



B.P 59
59450 SIN LE NOBLE - FRANCE
TEL (33) 27.93.08.08
TELEX 820 221
TELEFAX (33) 27.93.08.00

TREUIL DE LEVAGE PNEUMATIQUE
DRUCKLUFT SICHERHEITS-HUBWINDE
AIR POWERED LIFTING WINCH

LIFTSTAR 300 R-L

NUMERO DE NOMENCLATURE

NUMERO DU DOCUMENT

9 4 0 7 0 7 1 1

LE CHEF DU BUREAU D'ETUDES

PLEASE CAREFULLY READ THE DIRECTIONS
FOR USE BEFORE STARTING UP

SUMMARY	FOLIO NBR.
* DESCRIPTION	1/1
* TECHNICAL DATA	1/1
* PRACTICAL ADVICE	
- Putting into operation	1/5
- Maintenance	2/5
- Particular instructions	2/5
- Overhauling	3/5
* WARRANTY	5/5
* SPARE PARTS	
- General view	1/4
- Spare parts list	2/4 - 3/4 - 4/4

LIFTSTAR® 300R

Portable air lifting winch

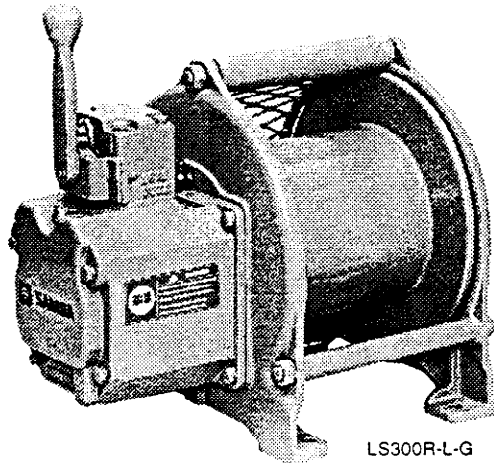

LS300R-L-G

DESCRIPTION

- Portable air winch, weight less than 30 kg, yet steel construction.
- Compact design for easy carrying using only one hand.
- Conforms with the most recent lifting standards (NF - ANSI - BSI - DIN) and with the requirements of certification authorities for Marine, Mines and Publics Works. FEM classification 1Bm.

Design:

- Plain drum between flanges with distance pieces, rope anchored by a horizontal self-tightening wedge.
- Planetary reduction gear enclosed in drum for protection and space saving.
- All rotating parts supported on anti-friction bearings.

Motor:

- Gear motor - Provides high starting torque.
- Motor reliability demonstrated by thousands of winches working in many mines. Simple rotating movement, more tolerant of poor quality air than other types of air motors.

SPECIFICATIONS			
Nominal load - Rated all layers (kg)		300	
Working pressure (bar)		4 to 7	
Rules and safety factors	$\frac{\text{Drum } \varnothing + \text{Rope } \varnothing}{\text{Rope } \varnothing} = \text{Factor R}$	36	24
	$\frac{\text{Rope breaking}}{\text{Nominal effort}} = \text{Factor K}$	5	6
Recommended rope diameter (mm)		4	6
Minimum breaking load (kg)		1500	1800
Recommended rope grade (kg/mm ²)		220	180
Weight of std. model - without rope (kg)		28	
PERFORMANCE			
Line pulls and speeds (see curves overleaf)			
Max. free air consumption (m ³ /min)		2.2	

- Reduced noise level (air is exhausted through the drum, resonances are minimised).

Safety brake:

- Fail safe automatic disk brake.
- Independent from worm gear drive and generously designed for dynamic overloads of 125% and static of 150%.

Controls:

- Direct control on the winch using only one lever - giving infinitely variable speeds.
- An optional pilot remote control "PHS" (Pendent high sensitivity) with variable speed up to 20 m distance is available.

Options:

- "GC" version (great capacity) with long drum.
- Drum guard.
- Marine / Offshore paint.
- For haulage operations, this winch is offered in the PULLSTAR® version with declutchable drum (ask for details).

WARNING: This equipment is not to be used for lifting, supporting or transporting people, or lifting or supporting loads over people. Before installation see maintenance and operations manual for additional warnings and precautions.

SAMI **IA**

LIFTSTAR® 300R

Portable air lifting winch

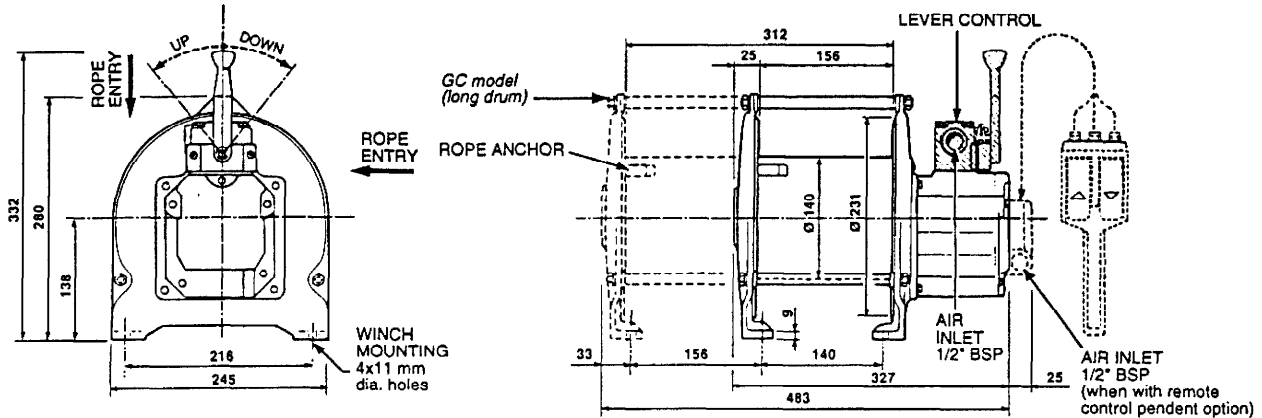

Performance at 6.3 bar - Rope 6mm dia.

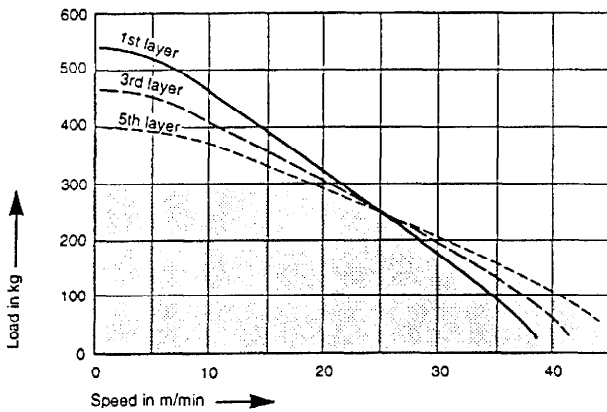

Cumulative rope capacity

Number of layers	1	2	3	4	5	6	7	8	9	10	
Capacity standard model (m)	Rope 4 mm Ø	16	33	52	71	91	112	134	157	181	206
	Rope 6 mm Ø	11	22	35	49	64	79	96	-	-	-
Capacity GC model (m)	Rope 4 mm Ø	32	66	104	142	182	224	268	314	362	412
	Rope 6 mm Ø	22	44	70	98	128	158	192	-	-	-

Rating limit →

How to order

Standard model: **LS300R-L**

For other configurations, use this identification code to order; Example: **LS300R-PH5M-G**

LS300R - PH 5M - G

LIFTSTAR	DRUM	CONTROL	OPTIONS
300	- = Standard	L = Lever	G = Drum guard
AIR	GC = Long drum	PH = Remote control	P = Marine paint
SRIES		PHS (alloy)	Q = Offshore paint
		PB = Remote control	Z = Sandblast preparation & special primer
		PHS (brass)	
		Length of remote control in metres	

Accessories:

- Steel lubricator 3/4" BSP
- Steel lubricator 3/4" BSP x 1/2" BSP
- Steel air filter 3/4" BSP
- Steel air filter 3/4" x 1/2" BSP
- Filter-lubricator (F.L.) 1/2" BSP
- Filter-regulator-lubricator (F.R.L.) 1/2" BSP

The equipment described on this sheet is subject to the general sales and warranty conditions of Ingersoll-Rand - Division SAMIIA. Because of the constant evolution of technology, SAMIIA reserves the right to modify without notice the specification of any equipment or accessory.



For the name of your local distributor, contact
INGERSOLL-RAND Equipement de Production,
Division SAMIIA ; fax (33) 27.93.08.00 (France)

PUTTING INTO OPERATION

* Network connection

The LIFTSTAR network connection to the compressed air supplying flexible is made on the inlet port \varnothing 1/2" G located on the distributor. The internal diameter of the supplying circuit does not be inferior to 13 mm for the flexibles and 10 mm for the connections.

Before connecting the supplying flexible to the LIFTSTAR, it is necessary to take away the air in order to exhaust impurities which should be in the flexible.

When starting the LIFTSTAR, we recommend you beginning supplying slowly in order to obtain a slow rotation of the motor and propelling it in the 2 directions during a few minutes with a good lubrication.

* Lubrication of the motor

We advice you to install an air treatment set near the equipment (maximum 3 meters) : Filter - Regulator - Lubricator code : 67763932, or Filter - Lubricator code 67770232.

The oiler must be regulated at 2/3 drops per minute. When filling in the oiler, the air inlet must be closed.

- Recommended oil : GRADE ISO 150
- Minimum viscosity : 135 Cst at 40°

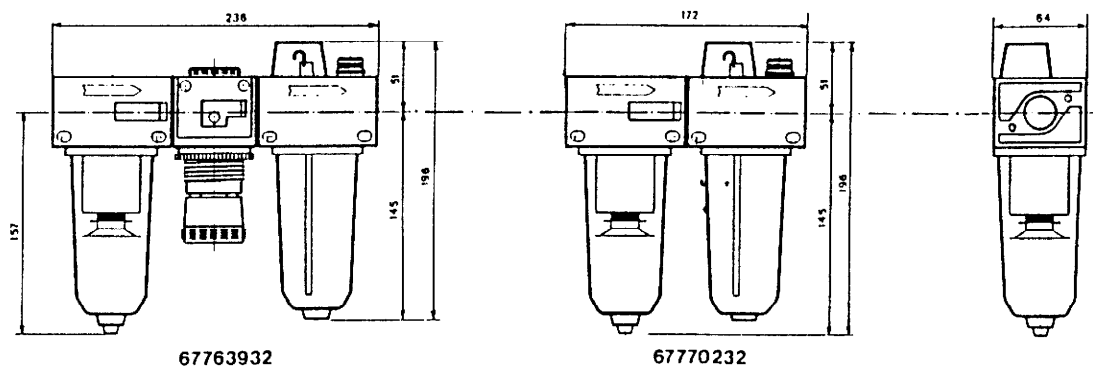

* Rope fitting

Introduce the rope in the drum according to the direction stated in the technical sheet (page 3).
Fit the wedge code : 9-618-0006
Make sure the rope appears on the drum flange.

MAINTENANCE

* Motor

If the LIFTSTAR is used in a continuous way, you will have to fill in the line oiler each day.

* Guiding belts

Monthly lubrication of the guiding belts with the oiler code : 67102227 (when lubricating, make an idle running of the drum).

Oil features :

Semi fluid oil extreme pressure for a room temperature from - 15° C to + 40° C,
ASTM at 25° C penetration.

CAUTION : THE OILS CONTAINING MOLYBDENUM ARE TO BE ABSOLUTELY PROSCRIBED.

PARTICULAR INSTRUCTIONS

* Before stopping the LIFTSTAR for a long period :

- Pour some cm3 of oil in the air inlet port or the supplying flexible.
- Propel the motor during 2/4 seconds
- Close the LIFTSTAR air inlet port

* When starting again :

Before a stopping period exceeding 1 month, we recommend to clean and lubricate the LIFTSTAR motor as follows :

- Pour approximately 10 cm3 of petroleum or gasoil in the air inlet port.
- Propel the motor during 10 seconds to exhaust any impurity.
- Pour some cm3 of oil in the air inlet port.
- Propel the motor during 2/4 seconds.

The LIFTSTAR is ready to work.

OVERHAULING

* BRAKE

The disc brake does not require any regulation, the yearly maintenance for this assembly being limited to :

- Dedusting
- Oiling the brake springs
- Replacing the disc brake when its thickness is inferior to 2,5 mm (original thickness : 3,2 mm).

CAUTION :

To access to the brake requires to dismount the carter / motor assembly
code : 6-618-0015.

When reassembling it, some precautions must be taken so that the coupling box code : 9-618-0014 and
the pin 46406118 be correctly fitted.

- Put the ring code : 9-618-0012 with the pin below
- Fit the carter / motor assembly, without the springs code : 69165532
- Dismount the carter / motor assembly
- Fit the springs
- Reassemble the carter / motor unit
- Make sure the mounting is correct by compressing the springs

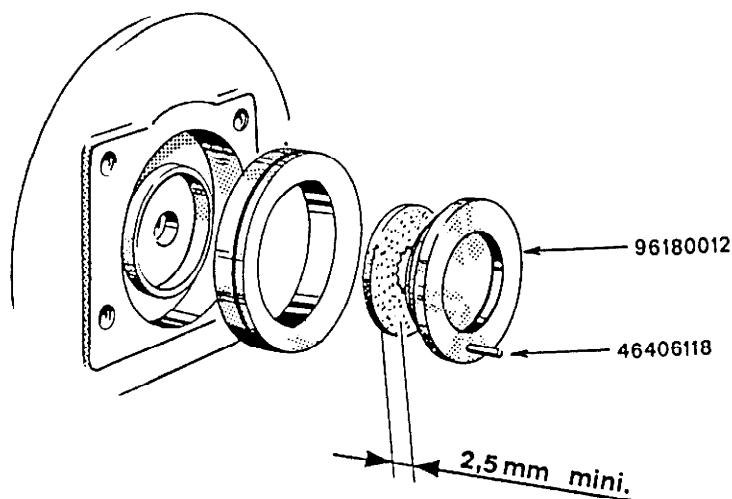

*** Reducer**

The yearly maintenance is limited to :

- Cleaning with petroleum
- Filling in the carter of the reducer with oil till the working rim be covered (oil capacity : 20 cl)

Recommended oil : GRADE SAE 80 W 90
Kinematic viscosity : 145 mm²/s at 40° C

CAUTION

As regards the reassembling of the reducer gearings, it is necessary to place the 3 planet wheels as follows, with the assistance of the codes carved on the lateral side of these planet wheels.

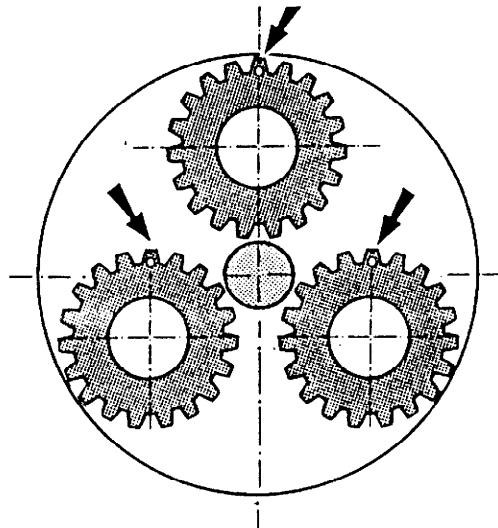
*** Motor**

As far as the yearly maintenance of the motor is concerned, act as described in the paragraph "when starting again".

If this operation is not sufficient, dismantle the motor and make :

- General cleaning
- Lubrication of the gears oil grade ISO 150 - Viscosity : 135 Cst at 40° C
- Addition of grease in the bearings

CAUTION

As regards the cleaning of the LIFTSTAR parts, use preferably :

PETROLEUM - GASOIL - ERGEOL -
NEVER CLEAN PARTS WITH TRICHLOROETHYLENE

Regarding the braking of the assembling screws, use an anaerobic resin, which allows dismounting without damage (resin type LOCTITE - BRAKE) (blue line or equivalent).

* Guiding belts

The guiding belts code : 9-618-0028 are 1,5 mm thick.
A 0,5 mm wear implies their replacement. Act as follows :

- Take away the guiding belts by hand.
- Carefully scrape the glue from the bearing.
- Put some glue stitches on the polished side of the belts : LOCTITE 406
(very little glue is necessary) (the connection between the belts must be
at 40 mm from the oiling hole).
- Place the guiding belts and set them in their housing
(DO NOT LEAVE ANY CLEARANCE BETWEEN THE BELTS AND THE BEARING).
- Lubricate the guiding belts before reassembling the drum.
Complete with the oiler.

WARRANTY

The warranty conditions for this equipment are those mentioned in the SAMIIA general sales conditions enclosed with our offers and printed on the back of our acknowledgements of receipt and invoices.

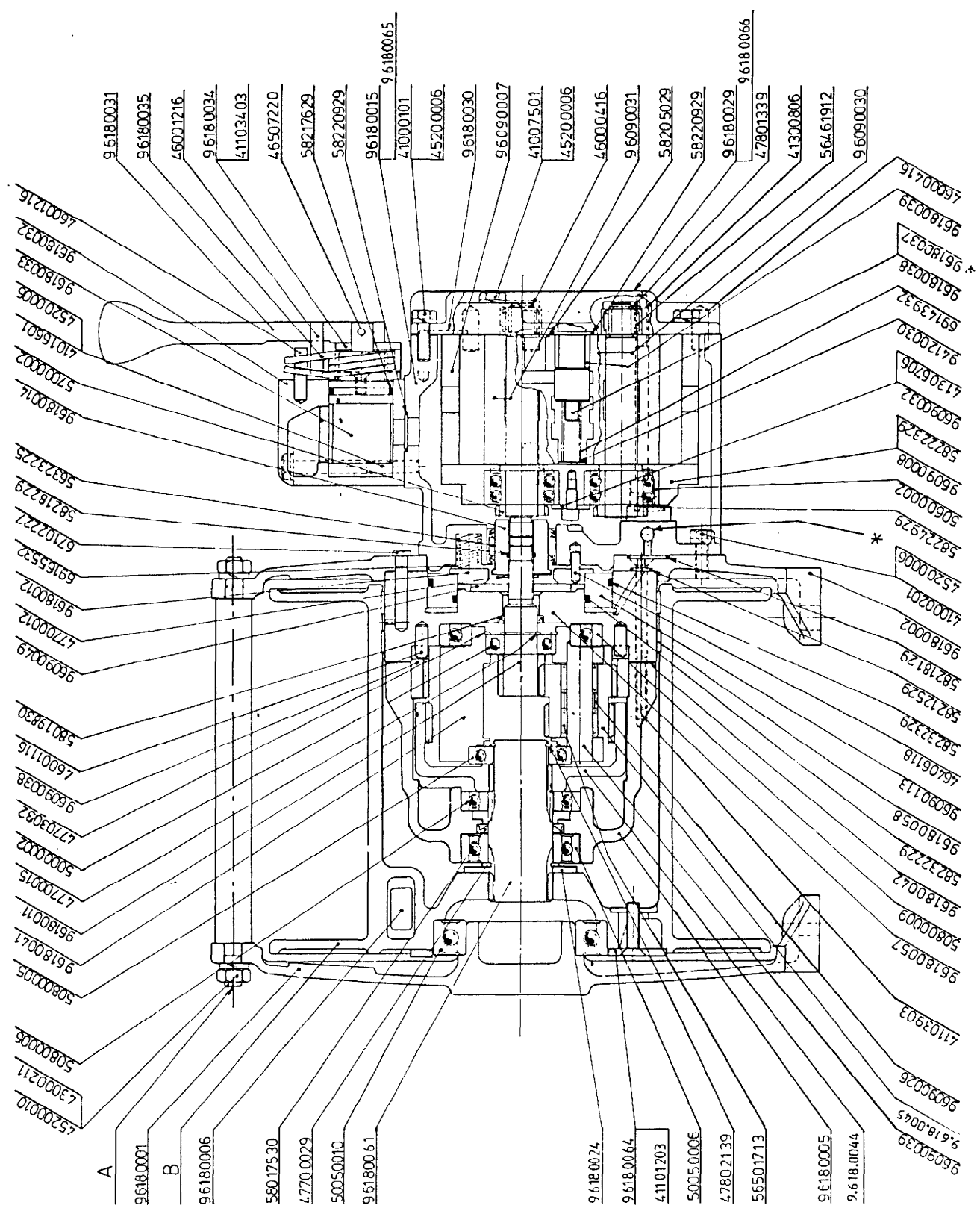

Par suite de l'évolution constante de la technique, nous pouvons être amenés à modifier sans préavis la conception et les caractéristiques de nos appareils ou accessoires.
Wir behalten uns vor im Zuge der technischen Entwicklung Bauart und technischen Daten unserer Maschinen und des Zubehörs zu ändern.
In our continous policy of improvement the right is reserved to make any change we think of benefit for our customers.



B.P 59
59450 SIN LE NOBLE - FRANCE
TEL (33) 27.93.08.08
TELEX 820 221
TELEFAX (33) 27.93.08.00

TREUIL DE LEVAGE PNEUMATIQUE
DRUCKLUFT SICHERHEITS-HUBWINDE
AIR POWERED LIFTING WINCH

LIFTSTAR 300 R-L

NUMERO DE NOMENCLATURE

NUMERO DU DOCUMENT

940709 | 2/4

LE CHEF DU BUREAU D'ETUDES

REPERE PART TEIL	QUANTITE QUANTITY ANZHAL	DESIGNATION	DESCRIPTION	BEZEICHNUNG
9.412.0030	1	Butée arrière	Rear stop	Anschlag hinten
9.609.0008	1	Flasque avant moteur	Motor front end-cover	AeuBeres Seitenteil des Motors
9.609.0026	3	Bague entretoise	Distance piece	Distanzring
9.609.0030	1	Ensemble rotor et répulsion	Rotor and repulsion assy	Rotor und Repulsion Einheit
9.609.0031	1	Ensemble rotor moteur	Motor rotor assy	Motor Rotor Einheit
9.609.0032	1	Rondelle	Washer	Scheibe
9.609.0038	1	Couronne 49 dents	49 teeth-ring gear	Zahnkranz 49 Zähne
9.609.0039	3	Axe de satellite	Satellite axle	Trabantenachse
9.609.0113	1	Piston de vérin	Cylinder piston	Zylinderkolben
9.609.0049	1	Disque de frein	Brake disc	Bremsscheibe
9.618.0001	1	Flasque arrière	Rear end-cover	Inneres Seitenteil
9.618.0002	1	Flasque avant	Front end-cover	AeuBeres Seitenteil
9.618.0005	1	Carter réducteur	Gear housing	Getriebegehäuse
9.618.0006	1	Coin	Wedge	Keil
9.618.0057	1	Palier	Bearing	Lager
9.618.0044	1	Couronne 47 dents	47 teeth-ring gear	Zahnkranz 47 Zähne
9.618.0045	3	Satellite	Satellite	Trabant
9.618.0061	1	Arbre de sortie	Output shaft	Abtriebswelle
9.618.0011	1	Pignon arbré	Shaft spindle	Ritzelwelle
9.618.0012	1	Rondelle d'appui	Washer	Scheibe
9.618.0014	1	Manchon d'accouplement	Coupling sleeve	Kupplungsmuffe
9.618.0015	1	Carter moteur	Motor housing	Motorgehäuse
9.618.0024	1	Entretoise	Spacer	Abstandring
9.618.0058	2	Bague de guidage	Guiding ring	Führungsring
9.618.0029	1	Couvercle moteur	Motor cover	Motordeckel
9.618.0030	2	Joint	Joint	Dichtung
9.618.0031	1	Levier de commande	Control lever	Steuerungshebel
9.618.0032	1	Corps de distributeur	Valve housing	Verteilergehäuse
9.618.0033	1	Carotte de distribution	Rotary valve	Umsteuerküken
9.618.0034	1	Butée	Stop	Anschlag
9.618.0035	1	Ressort de rappel	Return spring	Rückholfeder
9.618.0037	1	Obturateur	Blind washer	Dichtung
9.618.0038	1	Clapet	Stopper	Klappe
9.618.0039	1	Entretoise	Distance piece	Distanzring
9.618.0041	1	Porte-satellite	Satellite support	Satellitenträger
9.618.0042	1	Joint papier	Paper joint	Papierdichtung
9.609.0007	1	Corps moteur	Motor housing	Motorgehäuse
4.100.0101	3	Vis HM 6 x 20	Screw	Schraube
4.100.0201	4	Vis HM 6 x 15	Screw	Schraube
4.100.7501	2	Vis HM 6 x 25	Screw	Schraube
4.101.6601	4	Vis HM 6 x 60	Screw	Schraube
4.110.3403	2	Vis F Hc/90 M 5 x 10	Screw	Schraube
4.110.3903	4	Vis F Hc/90 M 6 x 70	Screw	Schraube
4.130.0806	4	Vis CHc M 6 x 80	Screw	Schraube
4.130.6706	1	Vis CHc M 5 x 10	Screw	Schraube
4.300.0211	6	Ecrou Hu 10	Nut	Mutter
4.520.0006	13	Rondelle Grower W 6	Washer	Scheibe
4.520.0010	6	Rondelle Grower W 10	Washer	Scheibe

Copyright SAMIIA

Pour toute commande de pièces de rechange, il est recommandé de rappeler le numéro porté sur la plaque d'identification de l'appareil
For each demand of spare parts, it is recommended to specify the number written on the identification plate of the device
Bei Bestellung von Ersatzteilen bitte Sereinnummer auf dem Identifizierungsschild des Geräte angeben



B.P 59
59450 SIN LE NOBLE - FRANCE
TEL (33) 27.93.08.08
TELEX 820 221
TELEFAX (33) 27.93.08.00

TREUIL DE LEVAGE PNEUMATIQUE
DRUCKLUFT SICHERHEITS-HUBWINDE
AIR POWERED LIFTING WINCH

LIFTSTAR 300 R-L

NUMERO DE NOMENCLATURE

NUMERO DU DOCUMENT

9140709134

LE CHEF DU BUREAU D'ETUDES

REPERE PART TEIL	QUANTITE QUANTITY ANZHAL	DESIGNATION	DESCRIPTION	BEZEICHNUNG
4.600.0416	6	Goupille 8 x 20	Pin	Stift
4.600.1116	2	Goupille 6 x 16	Pin	Stift
4.600.1216	2	Goupille 6 x 24	Pin	Stift
4.650.7220	1	Goupille 3x20	Pin	Stift
4.640.6118	1	Goupille G 05 4 x 14	Pin	Stift
4.770.0012	1	Circlips E 12	Circlips	Seegerring
4.770.0015	1	Circlips E 15	Circlips	Seegerring
4.770.0029	1	Circlips E 29	Circlips	Seegerring
4.770.3032	1	Circlips I 32	Circlips	Seegerring
4.780.1339	2	Segment d'arbre WR9	Shaft segment	Wellensegment
4.780.2139	1	Circlips A 25 x 1,2 V	Circlips	Seegerring
5.000.0002	1	Roulement à billes 6002	Ball bearing	Kugellager
5.005.0006	1	Roulement à billes 6006 2RS	Ball bearing	Kugellager
5.005.0010	1	Roulement à billes 6010 2RS	Ball bearing	Kugellager
5.060.0002	2	Roulement à billes 5202	Ball bearing	Kugellager
5.080.0005	1	Roulement à billes 16005	Ball bearing	Kugellager
5.080.0006	1	Roulement à billes 16006	Ball bearing	Kugellager
5.080.0009	1	Roulement à billes 16009	Ball bearing	Kugellager
5.632.3225	1	Roulement à aiguilles HK 25 x 16 x 2RS	Needle bearing	Nadellager
5.646.1912	2	Roulement à aiguilles NKI 9/12	Needle bearing	Nadellager
5.650.1713	6	Roulement à aiguilles K 12 x 17 x 13 TN	Needle bearing	Nadellager
5.700.0002	2	Ecrou KM 2	Nut	Mutter
5.801.7430	1	Bague d'étanchéité G 12x21x5	Sealing ring	Dichtring
5.801.7530	1	Bague d'étanchéité G 30x40x4	Sealing ring	Dichtring
5.820.5029	2	Joint torique OR 11 x 1,3	O'ring	O-Ring
5.821.2529	1	Joint torique OR 7,5 x 1,5	O'ring	O-Ring
5.821.8129	1	Joint torique OR 15 x 2,5	O'ring	O-Ring
5.821.8229	1	Joint torique OR 10 x 2	O'ring	O-Ring
5.821.7629	1	Joint torique OR 25 x 2,5	O'ring	O-Ring
5.822.0929	5	Joint torique OR 16 x 1,25	O'ring	O-Ring
5.822.2329	2	Joint torique OR 4 x 1	O'ring	O-Ring
5.823.2229	1	Joint torique OR 58 x 3	O'ring	O-Ring
5.823.2329	1	Joint torique OR 78 x 3	O'ring	O-Ring
5.822.4929	2	Joint torique OR 6 x 4	O'ring	O-Ring
6.710.2227	1	Graisseur	Greaser	Schmiernippel
6.914.3932	1	Ressort réf. 553	Spring	Feder
6.916.5532	4	Ressort T1 6,3x11,2x20	Spring	Feder
9.618.0064	1	Plaque d'échappement	Exhaust plate	Auslaßplatte
9.618.0065	1	Joint papier	Paper joint	Papierdichtung
9.618.0066	1	Joint papier	Paper joint	Papierdichtung
4.110.1203	4	Vis F Hc/90 M6 x 25	Screw	Schraube

Copyright SAMIIA

Pour toute commande de pièces de rechange, il est recommandé de rappeler le numéro porté sur la plaque d'identification de l'appareil
For each demand of spare parts, it is recommended to specify the number written on the identification plate of the device
Bei Bestellung von Ersatzteilen bitte Seriennummer auf dem Identifizierungsschild des Geräte angeben



B.P 59
59450 SIN LE NOBLE - FRANCE
TEL (33) 27.93.08.08
TELEX 820 221
TELEFAX (33) 27.93.08.00

TREUIL DE LEVAGE PNEUMATIQUE
DRUCKLUFT SICHERHEITS-HUBWINDE
AIR POWERED LIFTING WINCH

LIFTSTAR 300 R-L

NUMERO DE NOMENCLATURE

NUMERO DU DOCUMENT

9,4,0,7,0,9 | 4/4

LE CHEF DU BUREAU D'ETUDES

REPERE PART TEIL	QUANTITE QUANTITY ANZHAL	DESIGNATION	DESCRIPTION	BEZEICHNUNG
*		<u>Pièces non représentées</u>	<u>Not represented parts</u>	<u>Nicht dargestellte Teile</u>
9.609.0223	1	Butée de sélecteur	Selector stop	Selektorsanschlag
6.940.1625	1	Bille	Ball	Kugel
5.821.2229	1	Joint torique	O'ring	O-Ring
<u>A</u>				
9.618.0004	3	Entretoise standard	Standard distance piece	Standarddistanzring
9.618.0069	3	Entretoise GC	GC distance ring	GC Distanzring
<u>B</u>				
9.618.0055	1	Tambour standard	Standard drum	Standardtrommel
9.618.0068	1	Tambour GC	GC drum	GC Trommel
4.780.0639	6	Anneau Truarc 130 (TGC)	Ring (GC drum)	Ring (GC Trommel)
6.760.0303	6	Pastille d'échappement (TGC)	Exhaust washer (GC drum)	Auslaßscheibe (GC Trommel)

Copyright SAMIIA

Pour toute commande de pièces de rechange, il est recommandé de rappeler le numéro porté sur la plaque d'identification de l'appareil

For each demand of spare parts, it is recommended to specify the number written on the identification plate of the device

Bei Bestellung von Ersatzteilen bitte Sereinnummer auf dem Identifizierungsschild des Geräte angeben

EMERGENCY STOP VALVE ASSEMBLY PARTS LIST

ITEM NO	DESIGNATION OF PART	QTY TOTAL	PART NUMBER
• 172	O' Ring	9	5821-4829
173	Shuttle Valve Stop	1	9579-0098
174	Ball	1	6940-1625
175	Setscrew	3	4200-8207
176	Spring	3	6911-3941
177	Spool	3	9579-0085
178	Emergency Stop Bottom	1	6859-8632
179	Label Kit	1	9579-0099
201	Cover	1	9617-0059
202	Screw	7	4130-6706
203	Spring	1	6915-8732
• 204	O' Ring	1	5821-4829
205	Valve Cone	1	9617-0053
• 206	Joint	2	9617-0056
207	Washer	2	4570-0005
208	Screw	1	4130-8206
210	Distance Ring	1	9617-0055
211	Diaphragm	1	6771-6341
213	Cover	1	9617-0052
214	Valve Cone	1	9617-0054
216	Plug	1	6517-2032
217	Setscrew	1	4200-7407
218	Nozzle	1	9617-0071
219	Nipple	1	6313-0632
220	Body	1	9617-0069
221	Emergency stop Valve Assembly (incl's item 172 through 220)	1	3617-0017

•

Recommended Spare.

PHS2U REMOTE CONTROL ASSEMBLY DRAWING

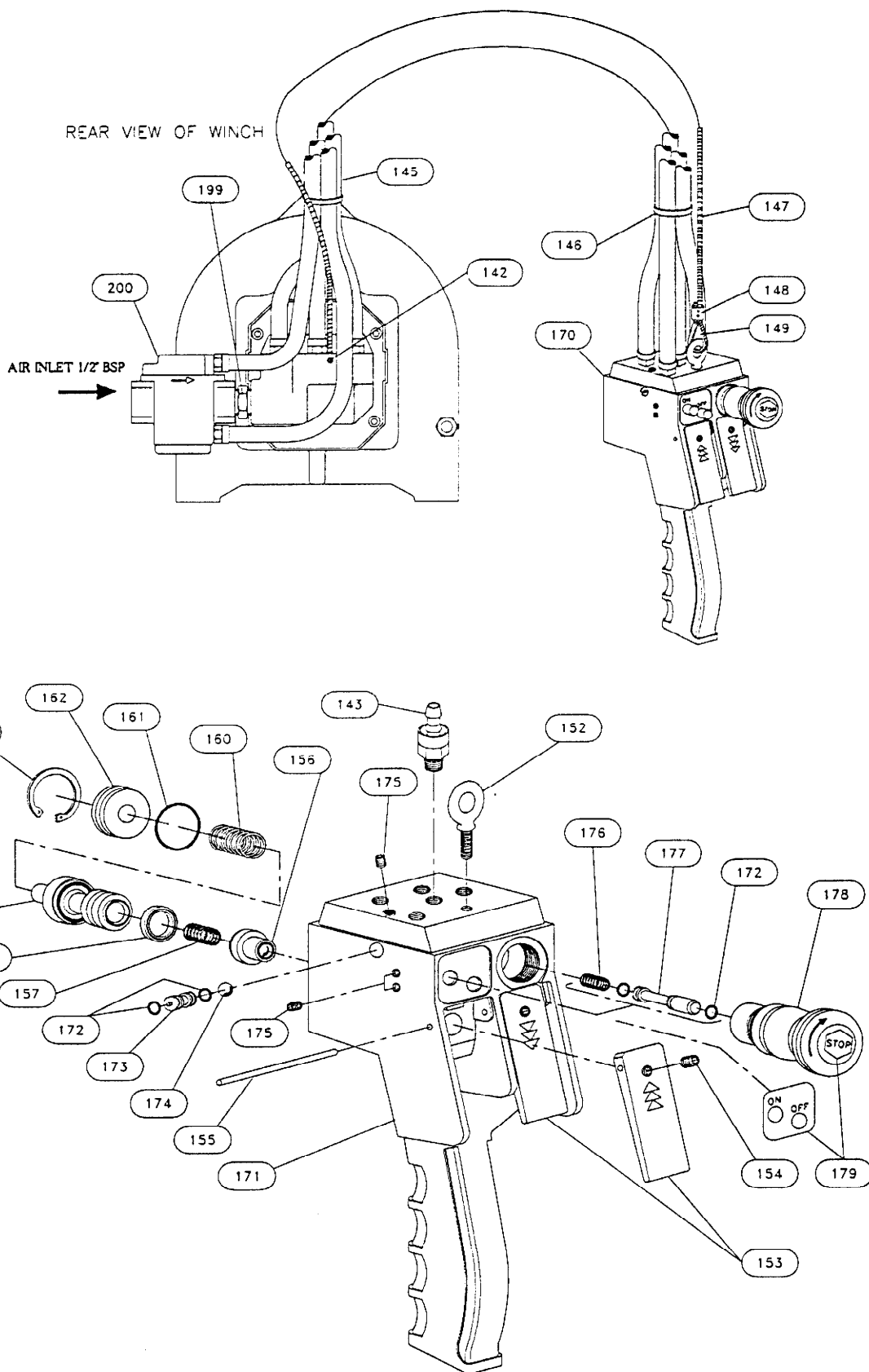

PHS2U REMOTE CONTROL ASSEMBLY PART LIST

ITEM NO	DESIGNATION OF PART	QTY TOTAL	PART NUMBER
142	Setscrew	1	4200-7707
143	Fitting	5	6165-2632
144	Meter of Control (incl's item 145 through 147)	(*)	3525-0013
145	Hose	5	-
146	Hose Tie	2/m	-
147	Strain Relief Wire	1	-
148	Sleeve Clamp	1	6112-5032
149	Thimble	1	6932-5332
152	Lifting Eye	1	6422-2332
153	Lever	2	9579-0038
154	Setscrew	2	4200-7407
155	Pin	1	9579-0040
156	Valve Assembly (with 'O' Ring crimped)	2	9579-0036
157	Spring	2	6915-8632
• 158	Quad Ring	2	5823-0229
159	Spool (with 'O' Ring crimped)	2	9579-0035
160	Spring	2	6915-8732
• 161	'O' Ring	2	5820-3729
162	Rear Cover	2	9579-0037
163	Retainer Ring	2	4770-3028
170	Pendant Control With Emergency Stop Assembly (incl's item 143, 152 through 163 and 171 through 184)	1	7579-0071
171	Pendant Handle	1	9579-0095
• 172	'O' Ring	8	5820-9229
173	Shuttle Valve Stop	1	9579-0098
174	Ball	1	6940-1625
175	Setscrew	3	4200-8207
176	Spring	3	6911-3941
177	Spool	3	9579-0085
178	Emergency Stop Bottom	1	6859-8632
179	Label Kit	1	9579-0099
183	Sticker (Not shown on drawing)	1	9617-0098
184	Sticker (Not shown on drawing)	1	9617-0100
199	Nipple	1	6133-0632
200	Shutt-off Valve Assembly	1	3617-0015

• Recommended Spare.

(*) Specify length of control when ordering

SHUT-OFF VALVE ASSEMBLY DRAWING AND PARTS LIST

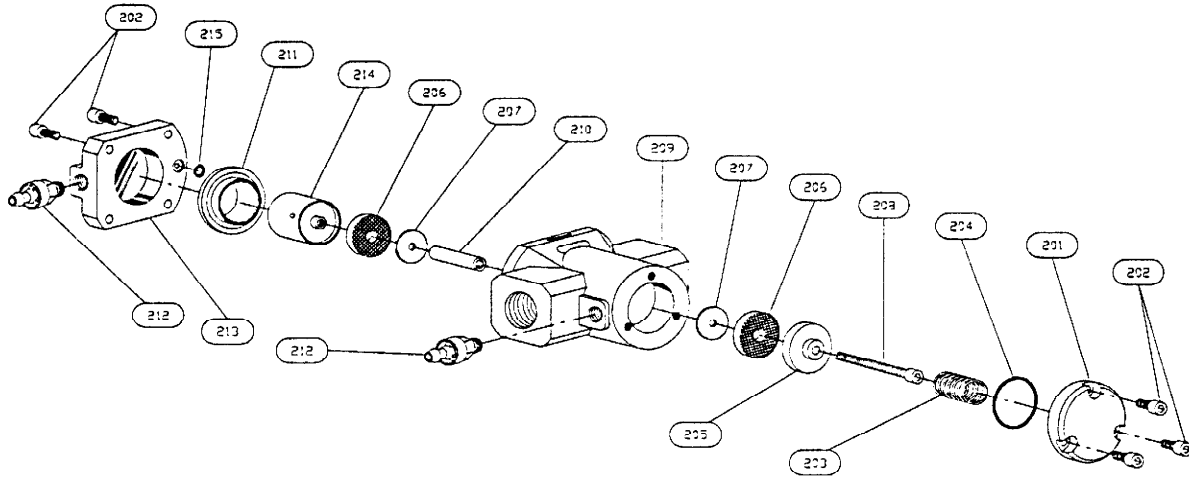

(Dwg.D6170004)

ITEM NO	DESIGNATION OF PART	QTY TOTAL	PART NUMBER
200	Shut-off Valve Assembly (incl's item 201 through 215)	1	3617-0015
201	Cover	1	9617-0059
202	Screw	7	4130-6706
203	Spring	1	6915-8732
• 204	O' Ring	1	5821-4829
205	Valve Cone	1	9617-0053
• 206	Joint	2	9617-0056
207	Washer	2	4570-0005
208	Screw	1	4130-8206
209	Body	1	9617-0051
210	Distance Ring	1	9617-0055
• 211	Diaphragm	1	6771-6341
212	Fitting	2	6165-2632
213	Cover	1	9617-0052
214	Valve Cone	1	9617-0054
• 215	O' Ring	1	5820-9229

• Recommended Spare.

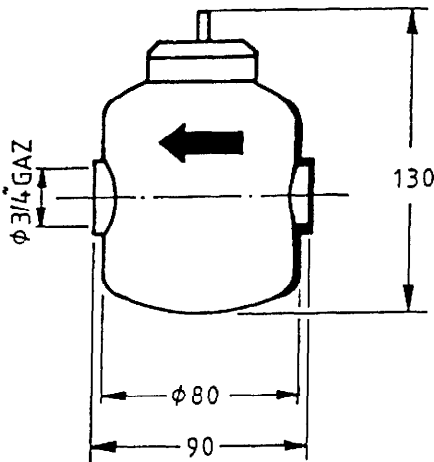

Côtes d'encombrement en mm

Masse über alles in mm

Overall Dimensions in mm

CARACTÉRISTIQUES

- Huileur à débit réglable pour installation fixe.
- Capacité 0,30 litre - Corps acier
- Valable pour débit de 500 à 5000 l/mn
- Pression d'utilisation 3 à 7 bar
- Diamètre d'entrée et sortie d'air filetés 3/4 gaz
- Poids : 1.200 Kg

BETRIEBSDATEN

- Öler mit einstellbarer Olabgabe für festen Bestandteilen
- Inhalt 0,30 Liter - Schale aus Stahl
- Für Durchfluss von 500 bis 5000 L/mn
- Betriebsdruck 3 bis 7 atü
- Lufteintritt und Luftaustritt 3/4" gasgewinde
- Gewicht : 1.200 kg

CHARACTERISTICS

- Oiler with adjustable flow for fixed installation
- Capacity 0.30 liter - Steel bowl
- Valid for air flow from 500 to 5000 l/mn
- Working pressure 3 to 7 kg/cm²
- Air entry and exhaust 3/4" gas
- Weight : 1,200 Kg

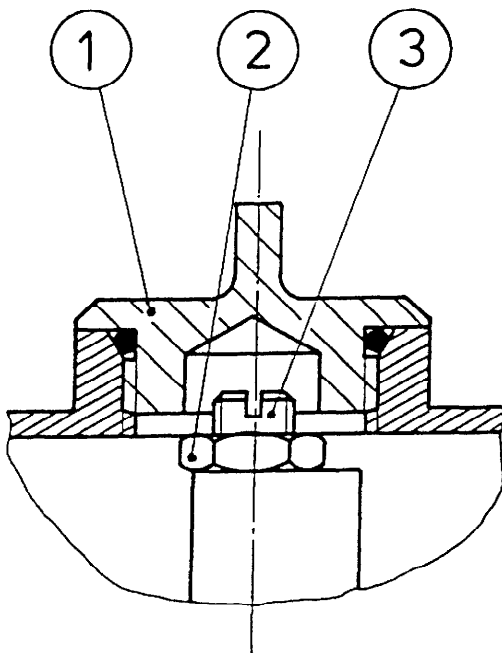
**REGLAGE DU DEBIT D'HUILE**

- .Fermer l'arrivée d'air - Dévisser le bouchon rep. 1
- .Desserrer le contre écrou rep. 2
- .Pour diminuer le débit d'huile, serrer la vis rep. 3
- .Pour augmenter le débit d'huile, desserrer cette vis (1/4 de tour suffit généralement)
- .Bloquer le contre écrou rep. 2 et remettre le bouchon

REGELUNG DER ÖLABGABE

- .Zuluft absperren - Stopfen Teil Nr1 abschrauben.
- .Kontermutter Teil Nr 2 lösen.
- .Für weniger Olabgabe, Schraube Teil Nr 3 abziehen
- .Für mehr Olabgabe, Schraube Teil Nr 3 lösen (1/4 Umdrehung genügt)
- .Kontermutter Teil Nr 2 blockieren und Stopfen 1 aufschrauben.

OIL ADJUSTMENT

- .Close the air inlet - unscrew plug part nbr 1
- .Loosen the lock nut part nbr 2. To reduce the oil flow, tighten screw part nbr 3. To increase the oil flow, loosen this screw (90° rotation is enough)
- .Screw the lock nut (part nbr 2) and install plug (part nbr 1)