

IMPORTANT INFORMATION:

- A copy of our “Safe Operating Practices” Manuals are always available free of charge either by downloading it from our Technical Publications website @ www.airwinch.com or by contacting the Factory at (800) 866-5457 for North America and (206) 624-0466 for International. The Safe Operating Practices manual must be read prior to anyone operating a **Ingersoll-Rand** winch or hoist. The manual form numbers are as follows:

“Safe Operating Practices Non-Man Rider™ Winches” Manual, Form No. MHD56250

“Safe Operating Practices for Man Rider™ Winches” Manual, Form No. MHD56251

“Safe Operating Practices for Pneumatic, Hydraulic and Electric Hoists” Manual, Form No. MHD56295

- Available winch options may require additional supplements to the basic winch manual.
- For Man Rider™ winches ensure a copy of the Man Rider™ supplement is made available to the operator prior to winch operation.

Winch Man Rider™ Supplements:

Model:	Publication No.
FA2, FA2.5, FH2, FH2.5	MHD56046
FA5	MHD56042 and MHD56220
FA10	MHD56252
FA2.5A	MHD56236
FA2B and HU40A	MHD56207
FH10MR	MHD56212
Fulcrum Electric	MHD56277
LS500HLP/ LS1000HLP	SAM0004

Model:	Publication No.
LS500RLP	SAM0011
LS1000RLP	SAM0012
LS150RLP	SAM0082
LS150RLP/500/ 1000	SAM0115
LS150RLP and LS150PLP-PH	SAM0120
LS500RLP-E	SAM0122
LS150RLP- DP5M-F	SAM0184
LS150HLP	SAM0222

- We strongly recommend that ALL maintenance on **Ingersoll-Rand** equipment be carried out by personnel certified by **Ingersoll-Rand**, or by **Ingersoll-Rand** Authorized Service Centers.
- Contact the Factory if in doubt about installation, operation, inspection and maintenance instructions.
- Use only Genuine **Ingersoll-Rand** parts when maintaining or repairing a winch, hoist or any component of a winch or hoist.
- ANSI / ASME recommends that a winch or hoist (or any components of a winch or hoist) that has been repaired be tested prior to being placed into service:
 - * **Winches** - ANSI / ASME B30.7 (BASE MOUNTED DRUM HOISTS) Refer to section 7.2.2 - Testing.
 - * **Hoists** - ANSI / ASME B30.16 (OVERHEAD HOISTS - UNDERHUNG) Refer to section 16.2.2 - Testing.

PARTS, OPERATION AND MAINTENANCE MANUAL

for

LIFTSTAR AND PULLSTAR

AIR WINCH MODELS

LS600R and PS1000R

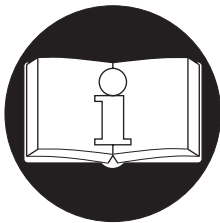
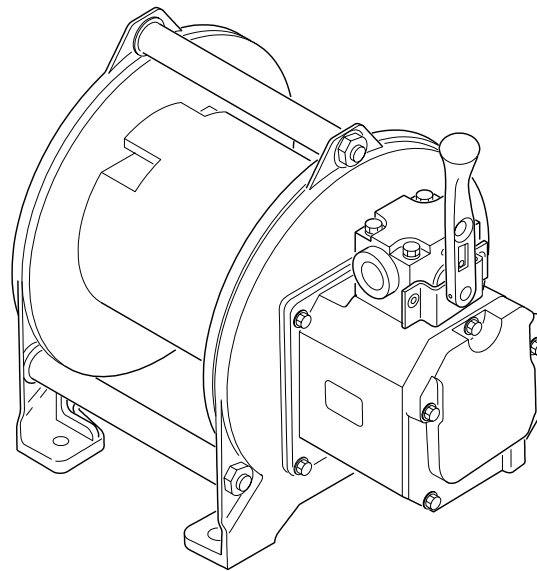

READ THIS MANUAL BEFORE USING THIS PRODUCT. This manual contains important safety, installation, operation and maintenance information. Make this manual available to all persons responsible for the operation, installation and maintenance of this product.

⚠ WARNING

Do not use this winch for lifting, supporting, or transporting people or lifting or supporting loads over people.

Always operate, inspect and maintain this winch in accordance with American National Standards Institute Safety Code (ASME B30.7) and any other applicable safety codes and regulations.

Refer all communications to the nearest Ingersoll-Rand Material Handling Office or Distributor.

Form MHD56035
Edition 3
June 1998
71061758
© 1998 Ingersoll-Rand Company

INGERSOLL-RAND

MATERIAL HANDLING

TABLE OF CONTENTS

Description	Page No.
Safety Information	
Danger, Warning, Caution and Notice	3
Safe Operating Instructions	4
Warning Label	4
Specifications	
Description of Operation	5
Model Code	5
Performance Graph	5
General Specifications	6
Installation	
Mounting	7
Wire Rope	7
Air Supply	8
Motor	9
Initial Operating Checks	9
Operation	
Winch Controls	10
Remote Pilot Pendant Control	10
Emergency Stop	10
Free Spool Clutch	11
Inspection	
Records and Reports	12
Frequent Inspection	12
Periodic Inspection	13
Winches Not in Regular Use	13
Inspection and Maintenance Report	14
Lubrication	
Lubrication Intervals	15
Reduction Gear Assembly	15
Drum Wear Rings	15
Seals and Bearings	15
Free Spool Clutch	15
Wire Rope	15
Troubleshooting	
Troubleshooting Chart	16
Maintenance	
Maintenance Intervals	17
General Disassembly Procedures	17
Disassembly Instructions	18
Cleaning, Inspection and Repair	19
Assembly Instructions	19
Testing	21
Parts	
Winch Assembly Drawings and Parts Lists	22-37
Parts Ordering Information	
Return Goods Policy	38
Warranty	39

SAFETY INFORMATION

This manual provides important information for all personnel involved with the safe installation, operation and proper maintenance of this product. Even if you feel you are familiar with this or similar equipment, you should read this manual before operating the winch.

Danger, Warning, Caution and Notice

Throughout this manual there are steps and procedures which, if not followed, may result in an injury. The following signal words are used to identify the level of potential hazard.

DANGER

Danger is used to indicate the presence of a hazard which *will* cause *severe* injury, death, or substantial property damage if the warning is ignored.

WARNING

Warning is used to indicate the presence of a hazard which *can* cause *severe* injury, death, or substantial property damage if the warning is ignored.

CAUTION

Caution is used to indicate the presence of a hazard which *will* or *can* cause injury or property damage if the warning is ignored.

NOTICE

Notice is used to notify people of installation, operation, or maintenance information which is important but not hazard-related.

Safety Summary

WARNING

- **Do not use this winch for lifting, supporting, or transporting people or lifting or supporting loads over people.**
- **The supporting structures and load-attaching devices used in conjunction with this winch must provide an adequate safety factor to handle the rated load, plus the weight of the winch and attached equipment. This is the customer's responsibility. If in doubt, consult a registered structural engineer.**

The National Safety Council, Accident Prevention Manual for Industrial Operations, Eighth Edition and other recognized safety sources make a common point: Employees who work near suspended loads or assist in hooking on or arranging a load should be instructed to keep out from under the load. From a safety standpoint, one factor is paramount: conduct all lifting or pulling operations in such a manner that if there were an equipment failure, no personnel would be injured. This means keep out from under a raised load and keep out of the line of force of any load.

Ingersoll-Rand Material Handling winches are manufactured in accordance with the latest ASME B30.7 standards.

The Occupational Safety and Health Act of 1970 generally places the burden of compliance with the user, not the manufacturer. Many OSHA requirements are not concerned or connected with the manufactured product but are, rather, associated with the final installation. It is the owner's and user's responsibility to determine the suitability of a product for any particular use. It is recommended that all applicable industry, trade association, federal, state and local regulations be checked. Read all operating instructions and warnings before operation.

Rigging: It is the responsibility of the operator to exercise caution, use common sense and be familiar with proper rigging techniques. See ASME B30.9 for rigging information, American National Standards Institute, 1430 Broadway, New York, NY 10018.

This manual has been produced by **Ingersoll-Rand** to provide dealers, mechanics, operators and company personnel with the information required to install, operate, maintain and repair the products described herein.

It is extremely important that mechanics and operators be familiar with the servicing procedures of these products, or like or similar products, and are physically capable of conducting the procedures. These personnel shall have a general working knowledge that includes:

1. Proper and safe use and application of mechanics common hand tools as well as special **Ingersoll-Rand** or recommended tools.
2. Safety procedures, precautions and work habits established by accepted industry standards.

Ingersoll-Rand cannot know of, or provide all the procedures by which product operations or repairs may be conducted and the hazards and/or results of each method. If operation or maintenance procedures not specifically recommended by the manufacturer are conducted, it must be ensured that product safety is not endangered by the actions taken. If unsure of an operation or maintenance procedure or step, personnel should place the product in a safe condition and contact supervisors and/or the factory for technical assistance.

SAFE OPERATING INSTRUCTIONS

The following warnings and operating instructions have been adapted in part from American National (Safety) Standard ASME B30.7 and are intended to avoid unsafe operating practices which might lead to injury or property damage.

Ingersoll-Rand recognizes that most companies who use winches have a safety program in force at their facility. In the event that some conflict exists between a rule set forth in this publication and a similar rule already set by an individual company, the more stringent of the two should take precedence.

Safe Operating Instructions are provided to make an operator aware of dangerous practices to avoid and are not necessarily limited to the following list. Refer to specific sections in the manual for additional safety information.

1. Only allow personnel trained in safety and operation of this winch to operate and maintain this product.
2. Only operate a winch if you are physically fit to do so.
3. When a **"DO NOT OPERATE"** sign is placed on the winch, or controls, do not operate the winch until the sign has been removed by designated personnel.
4. Before each shift, check the winch for wear and damage. Never use a winch that inspection indicates is worn or damaged.
5. Never lift a load greater than the rated capacity of the winch. Refer to the "SPECIFICATIONS" section.
6. Keep hands, clothing, etc., clear of moving parts.
7. Never place your hand in the throat area of a hook or near wire rope spooling onto or off the winch drum.
8. Always rig loads properly and carefully.
9. Be certain the load is properly seated in the saddle of the hook. Do not support a load on the tip of a hook.
10. Do not "side pull" or "yard".
11. Make sure everyone is clear of the load path and there are no objects in the way of the load. Do not lift a load over people.
12. Never use the winch for lifting or lowering people, and never allow anyone to stand on a suspended load.
13. Ease the slack out of the wire rope when starting a lift or pull. Do not jerk the load.
14. Do not swing a suspended load.
15. Never leave a suspended load unattended.
16. Pay attention to the load at all times when operating the winch.
17. After use or when in a non-operational mode, the winch should be secured against unauthorized and unwarranted use.
18. The operator must maintain an unobstructed view of the load at all times.
19. Never use the winch wire rope as a sling.
20. Never operate a winch with twisted, kinked or damaged wire rope.
21. Shut off air supply before leaving winch unattended.
22. Do not do anything you believe may be unsafe.
23. Never splice a sling chain by inserting a bolt between links.
24. Do not force a chain or hook into place by hammering. Do not insert the point of the hook into a chain link.
25. Do not expose the sling chain to freezing temperatures, and do not apply sudden loads to a cold chain.

WARNING LABEL

Each unit is shipped from the factory with the warning label shown. If the label is not attached to your unit, order a new label and install it. Refer to the parts list for the part number. Label is shown smaller than actual size.

 **WARNING**

Failure to follow these warnings may result in death, severe injury or property damage:

- Do not operate this winch before reading operation and maintenance manual. 
- Do not lift people or loads over people.
- Do not lift more than rated load.
- Do not allow less than three wraps of wire rope to remain on drum at all times.
- Do not operate a damaged or malfunctioning winch.
- Do not remove or obscure warning labels.

Read the latest edition of ASME B30.7.
Comply with other federal, state and local rules.
P/N 71060529/C
for winches

INGERSOLL-RAND®
MATERIAL HANDLING

General Specifications			Model						
			LS600R		PS1000R				
Air System	Rated Operating Pressure		90 psig (6.3 bar)						
	Consumption Volume (at rated pressure)		78 scfm	2.2 cu.m/min	78 scfm	2.2 cu.m/min			
Rated Performance (at rated pressure/volume)	Top Layer Line Pull		1320 lbs	600 kgs	---	---			
	First Layer Line Pull		---	---	2200 lbs	1000 kgs			
	Top Layer Line Speed		34.5 fpm	10.5 m/min	---	---			
	First Layer Line Speed		---	---	15 fpm	4.5 m/min			
Net Weight (without Wire Rope)			60 lbs	27 kgs	62 lbs	28 kgs			
Air Motor Pipe Inlet Size			1/2 inch	13 mm	1/2 inch	13 mm			
Air System Hose Size			1/2 inch	13 mm	1/2 inch	13 mm			
Maximum Wire Rope Size			3/8 inch	9.5 mm	3/8 inch	9.5 mm			
Drum Wire Rope Storage Capacity * (feet/metres)		Drum Length		Wire Rope Diameter					
				in.	mm	1/4 inch **	6.5 mm **	5/16 inch **	8 mm **
		Standard Drum		6.1	156	292 ft	89 m	161 ft	49 m
		GC Drum		12.3	312	600 ft	183 m	335 ft	102 m
Factors for determining STALL and LINE PULL at various air pressures: To obtain performances at operating pressures other than 90 psi, select the load or speed rating required from the applicable curve and multiply that value by the factor corresponding to the operating pressure from the table. Example: Performance of Pullstar 1000R at 5 bar: Stall at mid-drum - 800 kg x 0.80 = 640 kg Speed at mid-drum with a 600 kg load - 10 m/min x 0.73 = 7.3 m/min.			Air Pressure		Stall Factor	Wire Rope Speed Factor			
							psi	bar	
					60	4	0.63	0.53	
					70	5	0.80	0.73	
					80	5.5	0.87	0.84	
					90	6.3	1	1	
		100	7	1.12	1.16				

* Recommended drum working storage capacity is 80% of values shown.

** Recommended wire rope size for both models.

Capacity Information

Liftstar (LS600R) winches are designed for lifting with a 5:1 minimum safety factor at rated load. Pullstar (PS1000R) winches are designed for pulling with a 3:1 minimum safety factor at rated line pull.

The Liftstar winch is designed to provide a constant line speed, with rated load, at any layer of wire rope.

Refer to the Performance Graph for the Pullstar winch line speed and pulling capacities at different layers.

The minimum ratio of drum to wire rope diameter is 18:1, with a safety factor of 5 for standard ropes.

INSTALLATION

Prior to installing the winch, carefully inspect it for possible shipping damage.

Winches are supplied fully lubricated from the factory.

⚠ CAUTION

• Owners and users are advised to examine specific, local or other regulations, including American National Standards Institute and/or OSHA Regulations which may apply to a particular type of use of this product before installing or putting winch to use.

Mounting

1. Do not weld to any part of the winch.
2. The winch mounting surface must be flat and of sufficient strength to handle the rated load plus the weight of the winch and attached equipment. An inadequate foundation may cause distortion or twisting of the winch end covers and spacers resulting in winch damage.
3. Make sure the mounting surface is flat to within 1/32 inch (0.8 mm). Shim if necessary.
4. Mounting bolts must be 3/8 in. (10 mm) diameter, Grade 8 or better. Use self-locking nuts or nuts with lockwashers.
5. Tighten mounting bolts evenly and torque to 50 ft. lbs. (68 Nm) for dry thread fasteners. If the fasteners are plated, lubricated or a thread locking compound is used, torque to 35 ft. lbs. (47 Nm).
6. When a lead sheave is used, it must be aligned with the center of the drum. The diameter of the lead sheave must be at least 18 times the diameter of the wire rope.
7. Maintain a fleet angle between the lead sheave and winch of no more than 1-1/2 degrees. The lead sheave must be on a center line with the drum and, for every inch (25 mm) of drum length, be at least 1.6 feet (0.5 m) from the drum. Refer to Dwg. MHP0498.

Wire Rope and Drum Diagram

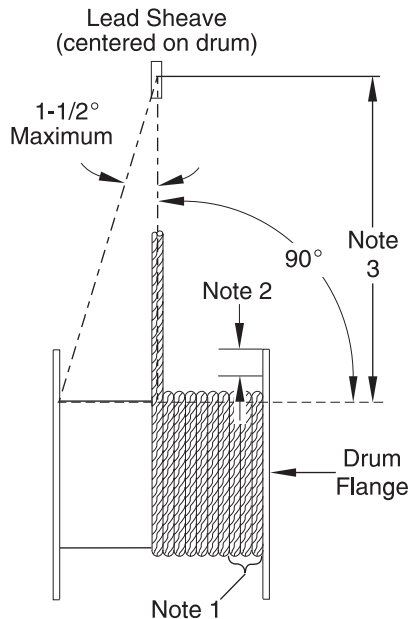

(Dwg. MHP0498)

Notes:

1. Maintain a minimum of 3 tight wraps of wire rope on the drum at all times.
2. Ensure the wire rope does not exceed top layer requirements. Refer to "SPECIFICATIONS" section.
3. Maintain a minimum of 1.6 feet (0.5 m) per inch of drum length. Example: for a 7 inch drum length, locate the lead sheave at least 11.2 feet (3.51 m) from drum.

Bolt Hole Mounting Dimensions

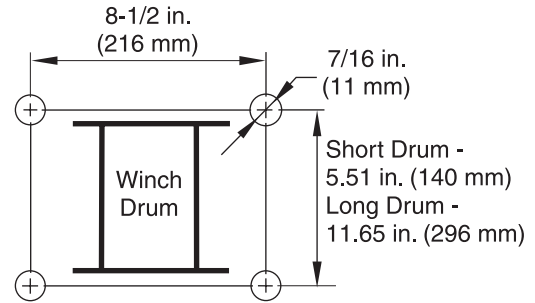

(Dwg. MHP0138)

Wire Rope

⚠ CAUTION

• Maintain at least 3 wraps of wire rope on the drum at all times. Refer to Dwg. MHP0498.

Wire Rope Selection

Consult a reputable wire rope manufacturer or distributor for assistance in selecting the appropriate type and size of wire rope and, where necessary, a protective coating. Use a wire rope which provides an adequate safety factor to handle the actual working load and meets all applicable industry, trade association, federal, state and local regulations. When considering wire rope requirements the actual working load must include not only the static or dead load but also loads resulting from acceleration, retardation and shock load. Consideration must also be given to the size of the winch wire rope drum, sheaves and method of reeving. Maximum wire rope diameter is limited by the wire rope anchor. Wire rope construction should be 6 x 37 Extra Improved IWRC right lay to permit correct installation of wire rope. Refer to Table 1 for minimum and maximum recommended wire rope diameters.

Installing Wire Rope

1. Cut wire rope to length in accordance with the wire rope manufacturer's instructions.
2. Feed the end of the wire rope into the smaller anchor hole in the wire rope drum and pull through approximately one foot (0.3 m) of wire rope.
3. Tuck the end of the wire rope back into the wire rope anchor pocket forming a loop in the wire rope.
4. Insert the wire rope anchor and pull the wire rope through the slot tightening the wire rope around the wire rope anchor.

⚠ CAUTION

- Make sure the first wrap of wire rope is flush against the drum flange.
- Install the wire rope to come off the drum in an overwind position as indicated on the direction of rotation label.

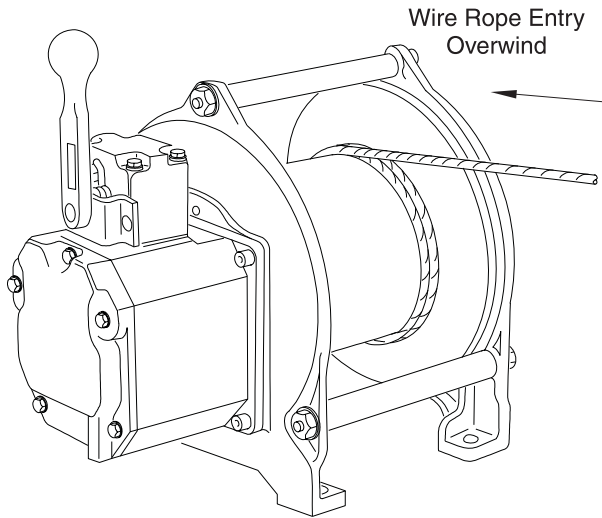

(Dwg. MHP0650)

5. It may be necessary to use a wood block or copper hammer to drive the wire rope and anchor into position. Ensure the loop in the wire rope is below the surface of the drum barrel diameter.

Table 1

Recommended Wire Rope Size				
Model	Minimum		Maximum	
	inch	mm	inch	mm
LS600	1/4	6.5	5/16	8
PS1000				
Rope Size (in.)	*Breaking strength (lbs)	Wt/ft (lbs)	**Recommended safe working load (lbs)	
			Pulling 3.5:1	Lift/Lower 5:1
1/4 (6 mm)	5880	0.11	2200	1320
5/16 (8 mm)	9160	0.18		

*Based on extra improved plow steel wire rope with independent wire rope core 6 x 37.

**ASME B30.7 requires a minimum of 3.5:1 wire rope design factor with 15:1 wire rope pitch diameter to drum diameter for most application (e.g. pulling/hauling and anchor handling). For lifting and lowering a 5:1 design factor with an 18:1 wire rope pitch diameter to drum diameter is required.

Wire Rope Spooling

To compensate for uneven spooling and decrease in line pull capacity as the drum fills up, use as short a wire rope as practical. When rewinding wire rope apply tension to eliminate slack. This helps achieve level winding and tight spooling.

Safe Wire Rope Handling Procedures

1. Always use gloves when handling wire rope.
2. Never use wire rope which is frayed or kinked.
3. Never use wire rope as a sling.
4. Always ensure wire rope is correctly spooled and first layer is tight against the drum.
5. Always follow wire rope manufacturer's recommendations on use and maintenance of wire rope.

Rigging

Make sure all wire rope blocks, tackle and fastenings have sufficient safety margin to handle the required load under all conditions. Do not allow wire rope to contact sharp edges or make sharp bends which will cause damage to wire rope, **use a sheave**. Refer to wire rope manufacturer's handbook for proper sizing, use and care of wire rope.

Safe Installation Procedures

1. Do not use wire rope as a ground (earth) for welding.
2. Do not attach a welding electrode to winch or wire rope.
3. Never run the wire rope over a sharp edge. Use a correctly sized sheave.
4. When a lead sheave is used, it must be aligned with the center of the drum. The diameter of the lead sheave must be at least 18 times the diameter of the wire rope.
5. Always maintain at least three full tight wraps of wire rope on the drum.

Air Supply

The air supply must be clean, free from moisture and lubricated to ensure optimum motor performance. Foreign particles, moisture and lack of lubrication are the primary causes of premature motor wear and breakdown. Using an air filter, lubricator and moisture separator will improve overall winch performance and reduce unscheduled downtime.

The air consumption is 78 scfm (2.2 cu. m/min.) at rated operating pressure of 90 psig (6.3 bar/630 kPa) at the winch motor inlet. If the air supply varies from what is recommended, winch performance will change.

Air Lines

The inside diameter of the winch air supply lines must not be smaller than 1/2 in. (13 mm) for flexible lines and 3/8 in. (10 mm) for connectors. Before making final connections, all air supply lines should be purged with clean, moisture free air or nitrogen before connecting to winch inlet. Supply lines should be as short and straight as installation conditions will permit. Long transmission lines and excessive use of fittings, elbows, tees, globe valves etc. cause a reduction in pressure due to restrictions and surface friction in the lines.

Air Line Lubricator

Refer to Dwg. MHP0191.

The air motor may be operated without lubrication. If an air line lubricator is used, it should be replenished daily and set to provide 2 to 3 drops per minute of ISO VG100 (30W) oil (minimum viscosity 135 Cst at 104° F (40° C)). The lubricator must have an inlet and outlet at least as large as the inlet on the motor. Install the lubricator as close to the air inlet on the motor as possible.

⚠ CAUTION

- Lubricator must be located no more than 10 ft. (3m) from the motor.
- Shut off air supply before filling air line lubricator.

Air Line Filter

Refer to Dwg. MHP0191.

Place the air line strainer/filter as close as practical to the motor air inlet port, but before the lubricator, to prevent dirt from entering the valve and motor. The strainer/filter should provide 20 micron filtration and include a moisture trap. Clean the strainer/filter periodically to maintain its operating efficiency.

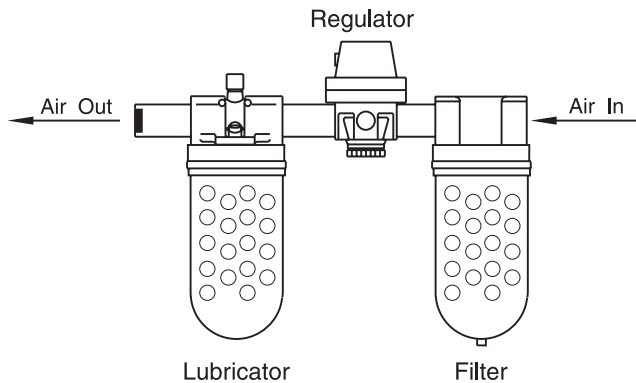

(Dwg. MHP0191)

Moisture in Air Lines

Moisture that reaches the air motor through air supply lines is a primary factor in determining the length of time between service overhauls. Moisture traps can help to eliminate moisture. Other methods, such as an air receiver which collects moisture before it reaches the motor or an aftercooler at the compressor that cools the air to condense and collect moisture prior to distribution through the supply lines are also helpful.

Motor

For optimum performance and maximum durability of parts, provide an air supply of 90 psig at 78 scfm (6.3 bar/630 kpa at 2.2 cu.m/min) as measured at the motor inlet. The winch should be installed as near as possible to the compressor or air receiver.

Initial Operating Checks

Winches are tested for proper operation prior to leaving the factory. Before the winch is placed into service the following initial operating checks should be performed.

1. When first running the motor some light oil should be injected into the inlet connection to allow good lubrication.
2. When first operating the winch it is recommended that the motor be driven slowly in both directions for a few minutes.

Start-Up Procedures

For winches that have been in storage the following start-up procedures are required.

1. Give the winch an inspection conforming to the requirements of "Winches Not in Regular Use" in the "INSPECTION" section.
2. Pour a small amount of ISO VG 32 (10W) oil in the motor inlet port.
3. Operate the motor for 10 seconds in both directions to flush out any impurities.
4. The winch is now ready for normal use.

OPERATION

The four most important aspects of winch operation are:

1. Follow all safety instructions when operating the winch.
2. Allow only people trained in safety and operation of the winch to operate the winch.
3. Subject each winch to a regular inspection and maintenance procedure.
4. Be aware of the winch capacity and weight of load at all times.

⚠ CAUTION

• To avoid damage to the rigging, the structure supporting the rigging and the winch, do not "two-block" the end of the wire rope.

* Two-blocking occurs when the winch wire rope is multi-reeved using two separate sheave blocks which are allowed to come into contact with each other during winch operation. When this occurs, extreme forces are exerted on the wire rope and sheave blocks, which may result in equipment and/or rigging failure.

⚠ WARNING

• The LS600 and PS1000 Winches are not designed or suitable for lifting, lowering or moving persons. Never lift loads over people.

Operators must be physically competent and have no health condition which might affect their ability to act. They must have good hearing, vision and depth perception. The winch operator must be carefully instructed in his duties and must understand the operation of the winch, including a study of the manufacturer's literature. The operator must thoroughly understand proper methods of hitching loads and should have a good attitude regarding safety. It is the operator's responsibility to refuse to operate the winch under unsafe conditions.

Winch Controls

The spring loaded, motor mounted, live air manual throttle control valve is supplied as a standard feature on this winch. Optional remote throttle controls are available. Reference the model code on the winch nameplate and compare it to the "SPECIFICATIONS" section of this manual to determine your configuration. The throttle control provides operator control of the motor speed and direction of drum rotation.

Winch Mounted Live Air Throttle (standard feature)

Refer to Dwg. MHP1326.

When viewed from the air motor end move the control throttle handle to the right (clockwise) to pay out wire rope.

When viewed from the air motor end move the control throttle handle to the left (counterclockwise) to haul in wire rope.

To ensure smooth operation of the winch avoid sudden movements of the control valve.

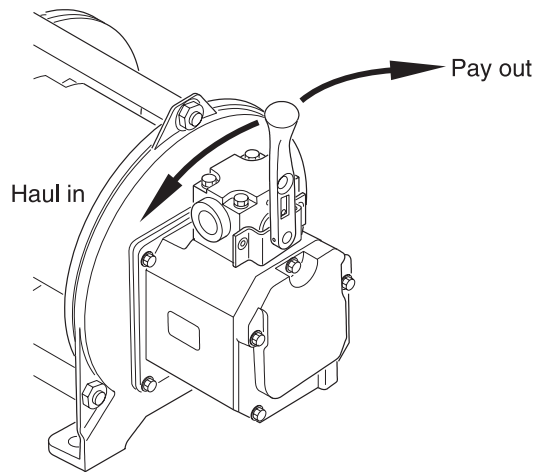

(Dwg. MHP1326)

Remote Pilot Pendant Throttle (optional feature)

Refer to Dwg. MHP1584.

Provides for remote winch control at distances up to 60 feet (18 metres) away from the winch motor. Pilot air hoses connect the throttle to the winch motor to provide winch operation. The pendant control throttle is a two lever movable control station for winch operation. Direction of rotation is determined by the pendant lever depressed.

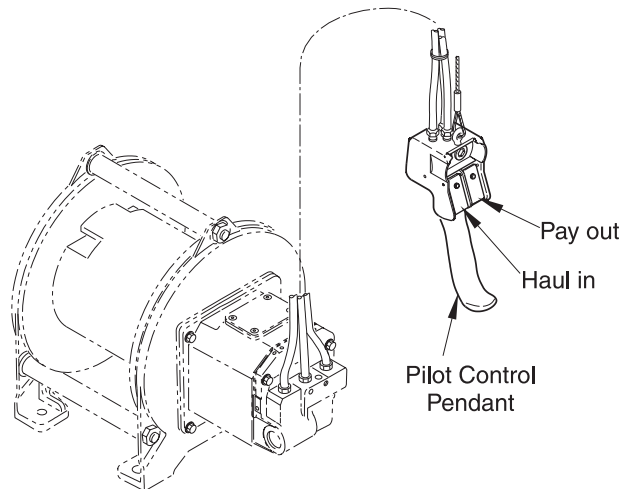

(Dwg. MHP1584)

Emergency Stop Device

Refer to Dwg. MHP1530 and MHP1546.

The emergency stop device is located at the air inlet of the winch on local control (winch mounted throttle) models and on the pendant of remote control models. When the emergency stop is activated, winch drum rotation ceases immediately.

1. To start winch operation, press the "ON" button.
2. To operate winch, press the "Haul in" or "Pay out" control lever.

3. In the event of an emergency, all winch operation can be stopped by pushing the emergency stop button. This will prevent air from reaching the winch motor, thereby stopping drum movement.
4. To restart the winch after the emergency stop has been activated, press the "ON" button.

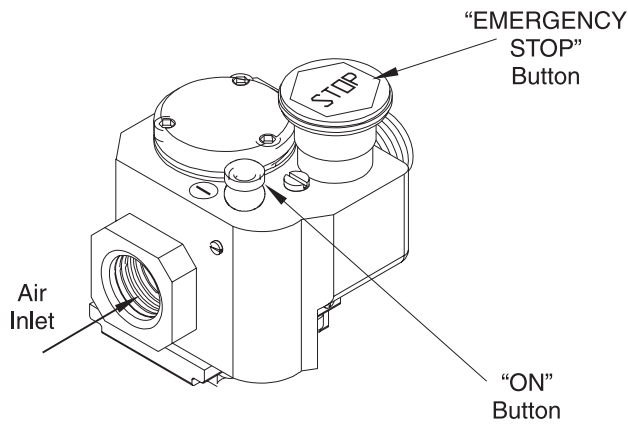

(Dwg. MHP1530)

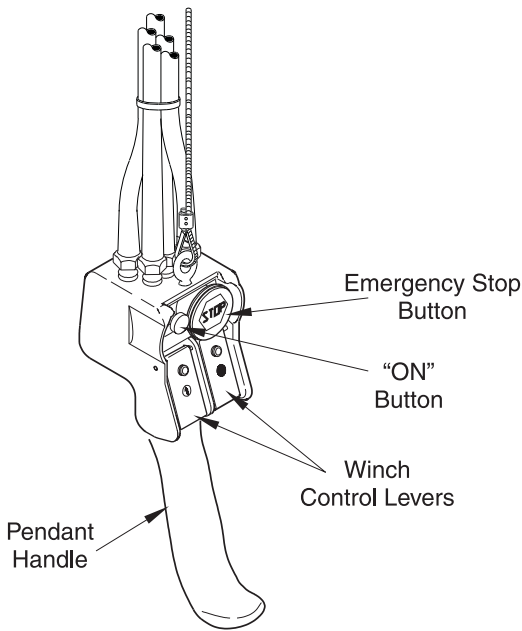

(Dwg. MHP1546)

Free Spool Clutch

Refer to Dwg. MHP0604.



- **Do not engage free spool clutch when motor is running or drum is spinning as this produces a severe strain on parts.**

To **disengage** the free spool clutch pull out the spring loaded plunger until it clears the groove in the handle shaft. Maintain a hold on the plunger knob and pull out the free spool clutch handle. Release the spring loaded plunger allowing it to lock back into the shaft groove. Gently pull and push on the free spool clutch handle to check plunger is engaged.

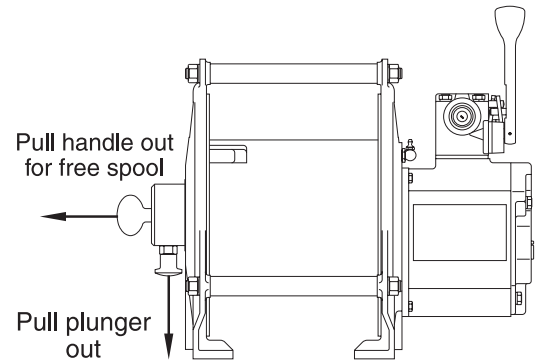

(Dwg. MHP0604)



- **Never disengage clutch with a load on the wire rope.**
- **Winch controls must be in the neutral position before operating the free spool clutch.**

To **engage** the free spool clutch pull out the spring loaded plunger until it clears the groove in the handle shaft. Maintain a hold on the plunger knob and push in the free spool clutch handle. Release the spring loaded plunger allowing it to lock back into the shaft groove. Gently pull and push on the free spool clutch handle to check plunger is engaged. It may be necessary to rotate the drum slowly by hand to allow the clutch drive shaft to engage.

Inspection information is based in part on American National Standards Institute Safety Codes (ASME B30.7).

WARNING

- **All new, altered or modified equipment should be inspected and tested by personnel instructed in safety, operation and maintenance of this equipment to ensure safe operation at rated specifications before placing equipment in service.**
- **Never use a winch that inspection indicates is damaged.**

Frequent and periodic inspections should be performed on equipment in regular service. Frequent inspections are visual examinations performed by operators or personnel trained in safety and operation of this equipment and include observations made during routine equipment operation. Periodic inspections are thorough inspections conducted by personnel trained in the safety, operation and maintenance of this equipment.

ASME B30.7 states inspection intervals depend upon the nature of the critical components of the equipment and the severity of usage. The inspection intervals recommended in this manual are based on intermittent operation of the winch eight hours each day, five days per week, in an environment relatively free of dust, moisture and corrosive fumes. If the winch is operated almost continuously or more than eight hours each day, more frequent inspections will be required.

Careful inspection on a regular basis will reveal potentially dangerous conditions while still in the early stages, allowing corrective action to be taken before the condition becomes dangerous.

Deficiencies revealed through inspection, or noted during operation, must be reported to designated personnel instructed in safety, operation and maintenance of this equipment. A determination as to whether a condition constitutes a safety hazard must be made, and the correction of noted safety hazards accomplished and documented by written report before placing the equipment in service.

Records and Reports

Inspection records, listing all points requiring periodic inspection should be maintained for all load bearing equipment. Written reports, based on severity of service, should be made on the condition of critical parts as a method of documenting **periodic** inspections. These reports should be dated, signed by the person who performed the inspection, and kept on file where they are readily available for authorized review.

Wire Rope Reports

Records should be maintained as part of a long-range wire rope inspection program. Records should include the condition of wire rope removed from service. Accurate records will establish a relationship between visual observations noted during frequent inspections and the actual condition of wire rope as determined by periodic inspections.

Frequent Inspection

On equipment in continuous service, frequent inspection should be made by operators at the beginning of each shift. In addition, visual inspections should be conducted during regular operation for indications of damage or evidence of malfunction.

1. **WINCH.** Prior to operation, visually inspect winch housings, control, spacers and drum for indications of damage. Any discrepancies noted must be reviewed and inspected further by authorized personnel instructed in the operation, safety and maintenance of this winch.
2. **WIRE ROPE.** Visually inspect all wire rope which can be expected to be in use during the day's operations. Inspect for wear and damage indicated by distortion of wire rope such as kinking, "birdcaging," core protrusion, main strand displacement, corrosion, broken or cut strands. If damage is evident, do not operate winch until the discrepancies have been reviewed and inspected further by personnel knowledgeable of wire rope safety and maintenance procedures.

NOTICE

- **The full extent of wire rope wear cannot be determined by visual inspection. At any indication of wear inspect the wire rope in accordance with instructions in "Periodic Inspection."**

3. **WIRE ROPE REEVING.** Check reeving and ensure wire rope is properly secured to the drum. Do not operate the winch unless the wire rope feeds onto the drum smoothly.
4. **AIR SYSTEM.** Visually inspect all connections, fittings, hoses and components for indication of air leaks. Repair any leaks or damaged components found.
5. **CONTROLS.** During operation of winch, verify response to control is quick and smooth. If winch responds slowly or movement is unsatisfactory, do not operate winch until all problems have been corrected. Lever must return to neutral when released.
6. **BRAKE.** During winch operation test brake. Brake must be capable of supporting the load without slipping. Brake must release when winch motor throttle is operated. If brake does not hold load, or does not release properly, the brake must be inspected and repaired.
7. **LUBRICATION.** Refer to the "LUBRICATION" section for recommended procedures and lubricants.
8. **PENDANT (optional feature).** Ensure operation of pendant levers is smooth and winch is responsive to pendant control. Pendant levers must spring back to a starting position.

Periodic Inspection

Periodic inspection intervals for winch use under various conditions is listed below:

NORMAL yearly	HEAVY semiannually	SEVERE quarterly
-------------------------	------------------------------	----------------------------

Disassembly may be required as a result of frequent inspection findings or in order to properly inspect the individual components. Disassembly steps are described in the "MAINTENANCE" section. Maintain written records of periodic inspections to provide an accumulative basis for continuing evaluation. Inspect all items listed in "Frequent Inspection." Also inspect the following:

1. **SPACER BARS and END COVERS.** Check for deformed, cracked or corroded main components. Replace damaged parts.
2. **FASTENERS.** Check retainer rings, capscrews, nuts, and other fasteners on winch, including mounting bolts. Replace if missing or damaged and tighten if loose.
3. **DRUM AND SHEAVES.** Check for cracks, wear or damage. Replace if necessary.
4. **WIRE ROPE.** In addition to Frequent Inspection requirements, also inspect for the following:
 - a. Build-up of dirt and corrosion. Clean with steam or a stiff wire brush to remove dirt and corrosion if necessary.
 - b. Loose or damaged end connection. Replace if loose or damaged.
 - c. Check wire rope anchor is secure in drum.
 - d. Verify wire rope diameter. Measure the diameter of the wire rope from crown-to-crown throughout the life of the wire rope. Recording of the actual diameter should only be done with the wire rope under equivalent loading and in the same operating section as accomplished during previous inspections. If the actual diameter of the wire rope has decreased more than 1/64 inch (0.4 mm) a thorough examination of the wire rope should be conducted by an experienced inspector to determine the suitability of the wire rope to remain in service. Refer to Dwg. MHP0056.

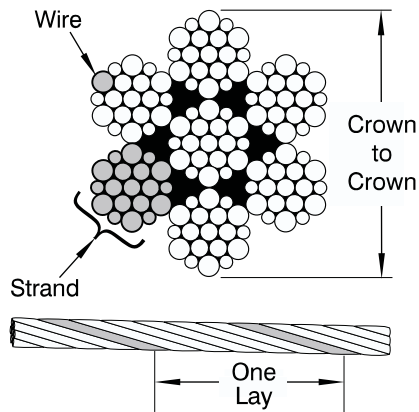

(Dwg. MHP0056)

5. **ALL COMPONENTS.** Inspect for wear, damage, distortion, deformation and cleanliness. If external evidence indicates damage, disassemble as required to conduct a detailed inspection. Inspect gears, shafts, bearings, sheaves, springs and covers. Replace worn or damaged parts. Clean, lubricate and reassemble.
6. **BRAKE.** Test brake to ensure proper operation. Brake must hold a 125% rated load with full drum without slipping. If indicated by poor operation, disassemble and repair brake. Check all brake surfaces for wear, deformation or foreign deposits. If brake lining thickness is less than minimum as described in the "MAINTENANCE" section replace brake. Clean and replace components as necessary.
7. **FOUNDATION OR SUPPORTING STRUCTURE.** Check for distortion, wear and continued ability to support winch and rated load. Ensure winch is firmly mounted and that fasteners are in good condition and tight.
8. **LABELS AND TAGS.** Check for presence and legibility of labels. Replace if damaged or missing.
9. **EMERGENCY STOP VALVE (optional feature).** During winch operation verify the emergency shut-off valve operation. Valve must stop winch operation quickly. Valve must reset properly. Refer to "Emergency Stop Valve" in the "OPERATION" section for procedures.
10. **DRUM GUARD (optional feature).** Verify that fasteners are tight and in good condition. Ensure guard is in good condition.

Winches Not in Regular Use

1. Equipment which has been idle for a period of one month or more, but less than six months, shall be given an inspection conforming to the requirements of "Frequent Inspection" before being placed in service.
2. Equipment which has been idle for a period of over six months shall be given a complete inspection conforming with the requirements of "Periodic Inspection" before being placed in service.
3. Standby equipment shall be inspected at least semi-annually in accordance with the requirements of "Frequent Inspection". In abnormal operating conditions equipment should be inspected at shorter intervals.

INSPECTION AND MAINTENANCE REPORT
INGERSOLL-RAND Models Liftstar 600R or Pullstar 1000R Air Winch

Model Number:	Date:
Serial Number:	Inspected by:

Reason for Inspection: (Check Applicable Box)	
1. Scheduled Periodic Inspection: ___ Quarterly ___ Semiannually ___ Yearly	Operating Environment: Normal ___ Heavy ___ Severe ___
2. Discrepancy(ies) noted during Frequent Inspection	
3. Discrepancy(ies) noted during Maintenance	
4. Other: _____	

Refer to the Parts, Operation and Maintenance Manual "INSPECTION" section for general inspection criteria. Also, refer to appropriate National Standards and codes of practice. If in doubt about an existing condition contact the nearest Ingersoll-Rand Distributor or the factory for technical assistance.

COMPONENT	CONDITION		CORRECTIVE ACTION		NOTES
	Pass	Fail	Repair	Replace	
Spacer Bars and End Covers					
Disc Brake (125% Load Test)					
Disc Brake (Visual Inspection)					
Motor					
Controls					
Air System					
Fasteners					
Reduction Gears					
Free Spool Clutch					
Labels and Tags			---		
Shafts					
Wire Rope Anchor			---		
Drum Guard					
Other Components (list in NOTES section)					

TESTING	Pass	Fail	NOTES
Operational (No Load)			
Operational (10% Load)			
Operational (Maximum Test Load *)			

* Maximum test load is 125% of rated line pull.

This form may be copied and used as an inspection/maintenance record.

LUBRICATION

To ensure continued satisfactory operation of the winch, all points requiring lubrication must be serviced with the correct lubricant at the proper time interval as indicated for each assembly.

The lubrication intervals recommended in this manual are based on intermittent operation of the winch eight hours each day, five days per week. If the winch is operated almost continuously or more than the eight hours each day, more frequent lubrication will be required. Also, the lubricant types and change intervals are based on operation in an environment relatively free of dust, moisture, and corrosive fumes. Use only those lubricants recommended. Other lubricants may affect the performance of the winch. Approval for the use of other lubricants must be obtained from your **Ingersoll-Rand** distributor. Failure to observe this precaution may result in damage to the winch and/or its associated components.

INTERVAL	LUBRICATION CHECKS
Start of each shift	Check flow and level of air line lubricator (approximately 2 to 3 drops per minute required at maximum motor speed).
Monthly	Inspect and clean or replace air line filter.
	Lubricate components supplied by grease fittings.
Yearly	Drain and refill winch reduction gear oil.

Reduction Gear Assembly

Replace the oil in the reduction housing at least once every year. Refer to Table 2. If the winch is used at a normal frequency, the oil in the reduction housing is suitable for one year's operation without being changed. However, when the winch is used at a high frequency, the oil may need to be changed more often.

To ensure correct performance, highest efficiency and long life, it is essential that the lubricating oil be maintained at the correct level. The recommended grade of oil must be used at all times since the use of unsuitable oil may result in excessive temperature rise, loss of efficiency and possible damage to the gears.

The reduction gear assembly is shipped with oil from the factory. Use only high quality lubricants in the reduction gear assembly such as high grade EP4 type oil. Fill the reduction gear assembly until the working rim is covered.

Table 2

Ambient Temperature	Recommended Oil Type
Below 32 F (0 C)	ISO VG 22 (50W)
30 to 80 F (0 to 26 C)	ISO VG 150 (90W)
Above 80 F (26 C)	ISO VG 460 (140W)

Drum Wear Rings

Lubricate grease fittings monthly with 2 or 3 pumps of a grease gun. Rotate the drum slowly as grease is being applied. Refer to Table 3.

Table 3

Ambient Temperature	Recommended Grease Type
-20 to 50 F (-30 to 10 C)	EP 1 multipurpose lithium-based
30 to 120 F (-1 to 49 C)	EP 2 multipurpose lithium-based

Seals and Bearings

If winch is disassembled, clean all parts thoroughly and coat bearings and seals with clean grease. Use sufficient grease to provide a good protective coat.

Free Spool Clutch

If winch is disassembled, apply a light coating of grease to the plunger and clutch handle shaft.

Wire Rope

Follow the wire rope manufacturer's instructions. At a minimum, observe the following guidelines.

1. Clean with a brush or steam to remove dirt, rock dust or other foreign material on the surface of the wire rope.



• Do not use an acid-based solvent. Only use cleaning fluids specified by the wire rope manufacturer.

2. Apply a wire rope lubricant, **Ingersoll-Rand LUBRI-LINK- GREEN®** or ISO VG 100 (30W) oil.
3. Brush, drip or spray lubricant weekly, or more frequently, depending on severity of service.

TROUBLESHOOTING

This section provides basic troubleshooting information. Determination of specific causes to problems are best identified by thorough inspections performed by personnel instructed in safety, operation and maintenance of this equipment. The chart below provides a brief guide to common winch problems, probable causes and remedies.

SYMPTOM	CAUSE	REMEDY
Winch will not operate.	No air supply to winch.	Check air supply line connections and hoses.
	Winch is overloaded.	Reduce load to within rated capacity.
	Disc brake does not release.	Inspect brake piston seals and replace if seals appear to be leaking.
Load continues to move when winch is stopped.	Brake is slipping.	Check brake friction disc wear.
	Winch is overloaded.	Reduce load to within rated capacity.
Winch does not lift load.	Motor may be damaged.	Remove and disassemble motor as described in the "MAINTENANCE" section. Examine all parts and replace any that are worn or damaged.
	Insufficient air supply.	Verify air supply pressure and volume at winch inlet meets the requirements listed in the "SPECIFICATIONS" section. Clean air line filter.
	Brake is not releasing.	Check brake release pilot hole is not restricted. Check seals on cylinder piston are not damaged. Brake will start to release at 50 psig (3.5 bar).
	Winch is overloaded.	Reduce load to within rated capacity.
Oil leaks from drum wear ring area.	Reduction assembly is leaking.	Disassemble winch and inspect reduction assembly seals.
Throttle (or pendant) lever moves but winch does not operate.	Motor may be damaged.	Disassemble and clean the motor and replace any broken or damaged parts.
	Insufficient air supply.	Ensure the air pressure at the winch inlet is at least 90 psig (6.3 bar/630 kPa) at rated volume. Clean air line filter.
Motor does not run smoothly or makes excessive noise during operation.	Worn or broken gear set bearings.	Examine each bearing. Install new bearings where necessary.
Winch runs slow.	Improper hose or fitting sizes.	Check fittings, connections and hoses for correct size and length. Replace parts that may cause restricted air flow. Inspect air line filter.
	Motor may be damaged.	Remove and disassemble motor as described in the "MAINTENANCE" section. Inspect all parts and replace all worn or damaged parts.
Air lines freeze.	Water in air supply.	Install or drain air system moisture traps, moisture collecting air receivers and compressor aftercoolers. After corrective actions have been taken, disconnect lines at winch inlet and purge with clean, dry air or nitrogen prior to attaching to and operating winch.

⚠ WARNING

- Never perform maintenance on the winch while it is supporting a load.
- Before performing maintenance, tag controls:
DANGER - DO NOT OPERATE - EQUIPMENT BEING REPAIRED.
- Only allow service personnel trained in safety and maintenance on this winch to perform maintenance.
- After performing any maintenance on the winch, test winch to 125% of its rated capacity before returning to service. Testing to more than 125% of rated capacity may be required to comply with standards outside the USA.
- Shut off air system and depressurize air lines before performing any maintenance.
- Do not use Trichloroethylene to clean parts.

Proper use, inspections and maintenance increase the life and usefulness of your **Ingersoll-Rand** equipment. During assembly, lubricate gears, nuts, capscrews and all machined threads with applicable lubricants. Use of antiseize compound and/or thread lubricant on capscrew and nut threaded areas prevents corrosion and allows for easy disassembly of components.

Maintenance Intervals

The Maintenance Interval chart is based on intermittent operation of the winch eight hours each day, five days per week. If winch operation exceeds eight hours per day, or use is under HEAVY or SEVERE conditions, more frequent maintenance should be performed. Refer to 'Periodic Inspection' in the "INSPECTION" section for interval guidance.

INTERVAL	MAINTENANCE CHECK
Start of each shift (Operator or Maintenance Personnel)	Make a thorough visual inspection of the winch for damage. Do not operate the winch if damaged.
	Operate the winch at low RPM in both directions. Winch must operate smoothly without sticking, binding or abnormal noises. Check the operation of the brake.
Yearly (Maintenance Personnel)	Inspect the winch gearing, shafts and bearings for wear and damage. Repair or replace as necessary.
	Inspect the brake disc. Clean or replace parts as required.
	Check all the supporting members, including the foundation, fasteners, nuts, sheaves and rigging, etc. for indications of damage or wear. Repair or replace as required.

Motor Removal

Refer to Dwg. MHP0454.

Use the following procedure to remove the motor.

1. Disconnect and tag the air lines.
2. Position several blocks of wood on the work bench and stand the winch in a vertical position with the motor end up. Make sure the weight of the winch does not rest on the free spool handle (10) or cause damage to the free spool parts.
3. Remove the four capscrews (96) and lockwashers (81) which connect the air motor to the front end cover (70) and remove the motor.

Brake

No brake adjustment is required.

It is recommended that the brake assembly be removed for maintenance and inspection once each year.

Use the following procedure to remove the brake.

1. Remove the motor as described above.
2. Remove the plate (64), brake disc (63) and brake piston (60).

No further disassembly is required, if only the brake is to be serviced.

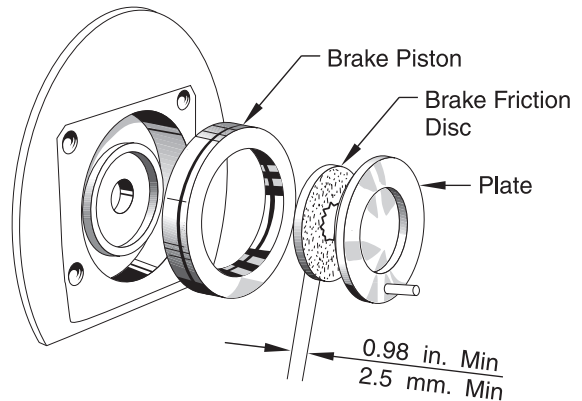

(Dwg. MHP0151)

Inspect the brake disc (63) for wear. If brake disc thickness is uneven or is less than 0.098 in. (2.5 mm) replace brake disc.

NOTICE

- Original brake disc thickness is 0.126 in. (3.2 mm)

General Disassembly Procedures

The following instructions provide the necessary information to disassemble, inspect, repair, and assemble the winch. Parts drawings are provided in the "Parts" section. In general, the winch is designed to permit easy disassembly and assembly. The use of heat or excessive force should not be required. If a winch is being completely disassembled for any reason, follow the order of the topics as they are presented. It is recommended that all maintenance work on the winch be performed on a bench. In the process of disassembling the winch, observe the following:

1. Never disassemble the winch any further than is necessary to accomplish the needed repair. A good part can be damaged during the course of disassembly.
2. Never use excessive force when removing parts. Tapping gently around the perimeter of a cover or housing with a soft hammer, for example, is sufficient to break the seal.
3. Do not heat a part with a flame to free it for removal, unless the part being heated is already worn or damaged beyond repair and no additional damage will occur to other parts.
4. Keep the work area as clean as practical, to prevent dirt and other foreign matter from getting into bearings or other moving parts.
5. All seals, 'O' rings and gaskets should be discarded once they have been removed. New seals, 'O' rings and gaskets should be used when assembling the winch.

6. When grasping a part in a vise, always use leather- or copper-covered vise jaws to protect the surface of the part and help prevent distortion. This is particularly true of threaded members, machined surfaces and housings.
7. Do not remove any part which is press fit in or on a subassembly unless the removal of that part is necessary for repairs or replacement.
8. When removing ball bearings from shafts, it is best to use a bearing puller. When removing bearings from housings, drive out the bearing with a sleeve or pipe slightly smaller than the outside diameter of the bearing. The end of the sleeve or pipe which contacts the bearing must be square. Protect bearings from dirt by keeping them wrapped in clean cloths.
5. If necessary remove bearing (50), oil seal (56) and ring gear (55) from the drum shaft (58).
6. Remove retainer ring (34) from the output shaft (35).
7. Remove planet gear assembly by tapping gently with a soft hammer on the output shaft (35).
8. Remove bearings (36 and 40) and oil seal (38) from gear housing (37) if being replaced.
9. Remove retainer rings (22) and (54) from sun gear (53) and press off bearing (19).
10. Push out pins (45) from planetary hub (47) and remove planetary gears (52), bearings (48), and spacers (49).
11. Remove retainer ring (46).
12. Remove bearing (44) and ring gear (42).

Disassembly Instructions

Winch Disassembly

Refer to Dwg. MHP0451.

1. Disconnect and tag the air lines.
2. Remove winch from its mounting and set in a clean work area on a sturdy work bench.
3. Position several blocks of wood on the work bench and stand the winch in a vertical position with the motor end up. Make sure the weight of the winch does not rest on the free wheel handle (10) or cause damage to the free wheel parts.
4. Remove the four capscrews (96) and lockwashers (81) which connect the air motor to the front end cover (70) and remove the motor. Set the motor to one side for further disassembly if needed.
5. Remove the coupling (92), retainer ring (67), plate (64), brake disc (63) and brake piston (60).
6. Remove the nuts (27) and lockwashers (28) securing the front end cover (70). Lift off the front end cover.
7. Remove the reduction gear assembly and set to one side for further disassembly if needed.
8. Remove spacer (24).
9. Separate the drum (32) from the rear end cover (15).
10. Remove drum bearing (16) and drum wear rings (33) if they are to be replaced.
11. Unscrew the handle (10) and pull the plunger (13) to remove axle (20), clutch (23) and spring (17).
12. If necessary remove retainer rings (18) and (22) to remove bearing (19) from axle (20).
13. Remove capscrews (11) securing the plunger body (14) and plunger (13) from the rear end cover (15).
14. Remove spacers (29), nuts (27) and lockwashers (28) from rear end cover.

Drum Wear Rings

Inspect drum wear rings (33) for wear. If thickness is less than 0.040 in. (1 mm) replace drum wear rings.

NOTICE

- **Original thickness of drum wear rings is 0.060 in. (1.5 mm).**

Reduction Gear Disassembly

Refer to Dwg. MHP0451.

1. Stand the reduction gear assembly in a vertical position so the output shaft (35) is down.
2. Remove the capscrews (72) that secure the front end cover to the gear housing and lift off front end cover.
3. Carefully pour the reduction gear assembly oil into a suitable container.
4. Remove the drum shaft (58) from the gear housing by tapping gently with a soft hammer on the sun gear (53).

Control Valve Disassembly

Refer to Dwg. MHP0454.

1. Remove capscrews (80) and lockwashers (81).
2. Remove the valve assembly from the motor.
3. Tap out pin (89) and extract the control lever (90).
4. Remove screws (88) and bracket stop (87).
5. Remove the spring (86).
6. Carefully slide out the rotary valve (84).
7. Remove 'O' ring (85).

Air Gear Motor Disassembly

Refer to Dwg. MHP0454.

Refer to Motor Removal Section to remove motor from winch.

1. Remove valve assembly from the motor.
2. Remove 'O' rings (97), springs (66) and coupling (92).
3. Remove the capscrews (124, 125) and lockwashers (81).
4. Remove the motor housing (94).
 - a. Remove gasket (99) and seals (122).
 - b. Remove 'O' rings (104).
5. Remove capscrews (111).
6. Remove the motor cover (123). If necessary, remove bearings (119), 'O' rings (97) and pins (103).
7. Remove the motor housing (112), spacer (140), stopper spool (116), spring (115), slide valve (113), washer (117) and the 'O' rings (110).
8. Immobilize the motor rotors with a rod between the teeth and remove nuts (107).
9. Remove the motor rotors (118), retainer rings (120).
10. Remove the screw (105) and the washer (106).
11. Remove bearings (108).

Pendant Disassembly (optional feature)

Refer to Dwg. MHP1544 or MHP1558.

1. Remove the fittings (327) and the lifting eye (501).
2. Unscrew plugs (518) and remove with springs (517) and balls (516).
3. Tap out pin (502) and remove the levers (503).
4. Remove screws (515) from pendant handle (514).
5. Remove the valve assemblies (items 506 and 509) with the 'O' rings (511 and 505).
6. Remove the emergency stop valve (508) or plug (507) from the handle (514).
7. Remove retainer ring (512) and exhaust washer (513).

Emergency Stop Disassembly

Refer to Dwg. MHP1585 and MHP1588.

1. Remove capscrews (184) securing covers (175 and 189). Remove covers.
2. Remove diaphragm (173).
3. Remove spring (191).
4. Remove 'O' rings (177 and 190) from covers (175 and 189).

5. Insert a long pin through the slot in the valve body to locate the hole in the valve cone (172) to prevent part rotation. Unscrew valve cone (172) from screw (185). Remove washer (170) and spacer tube (169). Remove screw (185) from valve cone (186) and second washer (170).
6. Remove seal washers (171) from recesses in valve cones (172 and 186).
7. Remove screw (188) and pull spool assembly from body (195). Remove ball (178) and spring (181).
8. Unscrew emergency stop button (192) from body. Remove ball (178) and spring (181).
9. Remove shuttle valve stop (176) with 'O' rings (177) and ball (178).

Cleaning, Inspection and Repair

Cleaning



- **A bearing that appears loose or does not rotate smoothly must be replaced. Failure to observe this precaution will result in bearing and/or winch component damage.**

Clean all winch component parts in solvent (except for the brake friction disc). The use of a stiff bristle brush will facilitate the removal of accumulated dirt and sediments in the drum and reduction assembly. If drum bushings have been removed it may be necessary to carefully scrape old Loctite® from the drum bushing bore. Dry each part using low pressure, filtered compressed air. Clean the brake friction disc using a wire brush or emery cloth. Do not wash the brake friction disc in liquid. If the brake friction discs are oil soaked, they must be replaced.

Inspection

All disassembled parts should be inspected to determine their fitness for continued use. Pay particular attention to the following:

1. Inspect all gears for worn, cracked, or broken teeth.
2. Inspect all bushings for wear, scoring, or galling.
3. Inspect all bearings for play, distorted races, pitting and roller or ball wear or damage. Inspect bearings for freedom of rotation.
4. Inspect shafts for ridges caused by wear. If ridges caused by wear are apparent on shafts, replace the shaft. Inspect all surfaces on which oil seal lips seat. These surfaces must be very smooth to prevent damage to the seal lip.
5. Inspect all threaded items and replace those having damaged threads.
6. Inspect the brake stationary plates and friction disc for oil. If the friction discs have become oil-soaked, replace them. If the stationary plates have become glazed, sand them lightly using fine emery cloth and a flat surface as backing. Inspect the remaining brake parts for warpage or other damage, and replace damaged parts as necessary. Replace the input pinion shaft oil seal.

Measure the thickness of the brake friction disc. The brake friction disc must show an even wear pattern. If the brake friction disc is 0.098 in. (2.5 mm) or less, replace the disc.

Repair

Actual repairs are limited to the removal of small burrs and other minor surface imperfections from gears and shafts. Use a fine stone or emery cloth for this work. Do not use steel wool.

1. Worn or damaged parts must be replaced. Refer to the applicable Parts Listing for specific replacement parts information.
2. Inspect all remaining parts for evidence of damage. Replace or repair any part which is in questionable condition. The cost of the part is often minor in comparison with the cost of redoing the job.
3. Smooth out all nicks, burrs, or galled spots on shafts, bores, pins, or bushings.
4. Examine all gear teeth carefully, and remove nicks or burrs.
5. Polish the edges of all shaft shoulders to remove small nicks which may have been caused during handling.
6. Remove all nicks and burrs caused by lockwashers.
7. Replace all gaskets, oil seals, and 'O' rings removed during winch disassembly.

Assembly

Reduction Gear Assembly

Refer to Dwg. MHP0451.

1. Install oil seal (38) in the bore of the gear housing (37) so seal lip is toward the planet assembly side.
2. Press bearings (36 and 40) into the gear housing (37).
3. Install retainer ring (34) on the output shaft (35) and press output shaft into the gear housing.
4. Install ring gear (42) on output shaft. Install bearing (44) on output shaft and secure in position with retainer ring (46).
5. Install two bearings (48) with a spacer (49) between in the bore of each planetary gear (52).
6. Position each assembled planetary gear in the planetary hub (47). Align pin holes and carefully install pins (45).
7. Install planetary gear assembly so each planetary gear (52) is positioned with the timing mark at the top. (Ref. Dwg. MHP0150).
8. Place the reduction gear assembly in a vertical position with the planetary gear end up. Fill the gear assembly to within 1 in. (25 mm) of the top with clean oil. Refer to "LUBRICATION" section.
9. Install oil seal (56) in the drum shaft (58) so seal lip is toward planetary gear side.

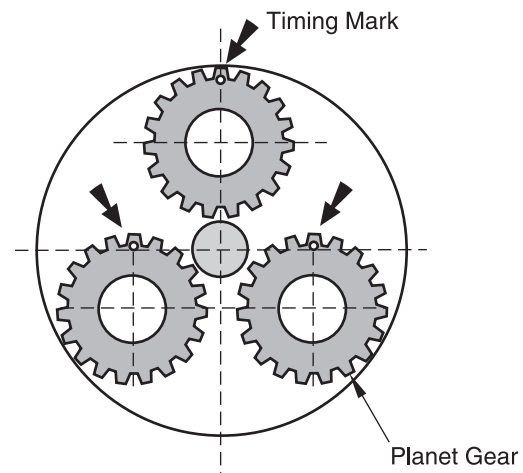

(Dwg. MHP0150)

10. Press bearing (19) onto the sun gear (53) and locate with retainer ring (54). Install sun gear (53) and bearing (19) in the drum shaft (58) and secure with retainer ring (22).
11. Install the drum shaft (58) and sun gear (53) on the gear housing (37) with a new gasket (39). Check that dowel pins (57) line up. Ensure the ring gear (42) and sun gear (53) mesh with the planet gears (52). Check rotation of planetary gears.
12. Secure front end cover (70) in position with capscrews (72).

Winch Assembly

Refer to Dwg. MHP0451.

1. If wear rings (33) are being replaced apply a bead of Loctite® 406 on the smooth surface of the new wear rings (surface which will contact the drum). Install wear rings (33) in the grooves provided in the drum (32). Press wear rings into position to eliminate any gaps between drum and wear rings. Gap between the ends of each wear ring should be approximately 1/8 in. (3 mm). Position wear ring gaps to ensure they are staggered (offset) from each other by 4 in. (100 mm).
2. Install bearing (16) in drum bore on rear end cover (15) side.
3. Place drum in an upright position with the small bore end facing up. Tap rear end cover into place in the drum bearing.
4. Install spacers (29), nuts (27) and lockwashers (28) on the rear end cover.
5. Turn winch over so the large bore end of the drum is up. Lubricate wear rings with grease and install reduction gear assembly in drum bore. Check that reduction gear assembly rotates freely in the drum wear rings. Partially lift out reduction gear assembly to check positioning of wear rings.
6. Lubricate and install 'O' ring (68) in brake release port on front end cover (70). Install front end cover so it lines up with the bolt holes and brake release port on the reduction gear assembly and with the spacers (29) in the rear end cover (15). Install screws (72).
7. Install nuts (27) and lockwashers (28) on spacers (29).
8. Install new 'O' rings (59) and (60) on the brake piston (60) then install the brake piston in the drum shaft (58).
9. Align splines in brake disc (63) bore and on sun gear (53) and install the brake disc. Check pin (65) is in position on plate (64) and install plate. Position plate with pin at the bottom.
10. Lubricate and install 'O' ring (91) in coupling (92) bore and place on sun gear (53).
11. Temporarily install the motor on the front end cover (70) to ensure pin (65) in plate (64) aligns with locating hole in motor housing (94). Remove motor and install brake springs (66). Reinstall motor and secure with capscrews (96) and lockwashers (81).
12. Place the winch in a horizontal position and install free wheel assembly on the rear end cover (15).

Control Valve Assembly

Refer to Dwg. MHP0454.

1. Lubricate and install 'O' ring (85) on rotary valve (84).
2. Lubricate and carefully install rotary valve in valve housing (82).
3. Lubricate and install spring (86) on rotary valve. Ensure pin (83) is installed in valve housing (82).
4. Install bracket stop (87). Apply a small amount of Loctite® 243 to threads of screws (88) and install.
5. Install control handle (90) on rotary valve and align pin hole. Install pin (89) to secure control handle.

6. Lubricate and install 'O' rings (97) on motor housing (94).
7. Install control valve assembly on motor with capscrews (80) and lockwashers (81).

Air Gear Motor Assembly

Refer to Dwg. MHP0454.

1. Lubricate bearings (108) with grade 2 grease then install bearings in motor front plate (109). Ensure markings on bearing cage are still visible after installation.
2. Install screw (105) and washer (106).
3. Install motor rotors (118) and retainer rings (120).
4. Immobilize the motor rotors with a rod between the teeth and install nuts (107). Lightly coat nut threads with Loctite® 234.
5. Install motor housing (112) on motor front plate.
6. Install spacer (140), washer (117), stopper spool (116), spring (115) and slide valve (113) in motor housing (112).
7. Install bearings (119) in motor cover (123). Install motor cover on motor housing (112). Ensure pins (103) are fully aligned and engaged. Secure with capscrews (111). Lightly coat capscrew threads with Loctite® 234.
8. Install gasket (99) and seals (122).
9. Install bearing (102) in motor housing (94).
10. Install assembly in motor housing (94) and secure with capscrews (124, 125) and lockwashers (81).
11. After assembly of the air motor, check to ensure motor turns smoothly in both directions.
12. Lubricate and install 'O' rings (97) on motor housing (94).
13. Install control valve assembly on motor with capscrews (80) and lockwashers (81).
14. Lubricate and install 'O' ring (91) in coupling (92) bore and place on sun gear (53).
15. Mount motor to winch and secure with capscrews (96) and lockwashers (81).

Pendant Assembly (optional feature)

Refer to Dwg. MHP1558 or MHP1544.

1. Install 'O' rings (505 and 511) and protector (506) on valves (509). Install valve assemblies in handle (514).
2. Install levers (503) in pendant handle (514) with pin (502). Stake pin in pendant handle at both ends to secure.
3. Install screws (504) in levers.
4. Install screws (515) in handle.
5. Install balls (516) and springs (517) in handle (514). Secure in position with plugs (518).
6. On pendants with emergency stop, install emergency stop button (508).
7. Install exhaust washer (513) and secure in handle with retainer ring (512).
8. Adjustment:
 - a. Connect the inlet of the pendant to 100 psi (7 bar) air supply.
 - b. Connect a manometer at the outlet of the lever to be adjusted.
 - c. Apply a small amount of Loctite® No. 243 on the adjustment screw (504).
 - d. Tighten the adjustment setscrew to obtain a pressure of 15 psi (1 bar) without actioning the lever.
 - e. Release the adjustment setscrew by a half turn (pressure must fall to zero).
 - f. Push the lever. Check that pressure reaches 93 +/- 7 psi (6.5 +/- 0.5 bar). Check that there is no leak at the exhaust.
 - g. Release the lever, exhaust must occur and result in rapid pressure reduction.

- h. Repeat operations f and g from 2 to 3 times.
- i. Disconnect the manometer. Check to ensure that there are no leaks when the lever is not activated.
- j. Repeat the operations from 6b. to 6i. with each lever.

Emergency Stop Assembly

Refer to Dwgs. MHP1585 and MHP1588.

1. Install seal washers (171) in recesses provided in valve cones (172 and 186).
2. Install screw (185) through valve cone (186) and washer (170). Install assembly in valve body (195) from the side with the three hole cover (189). Install spacer tube (169) and washer (170) on screw (185). Apply Loctite® 243 to threads and screw valve cone (172) onto screw and tighten by inserting a long pin through the slot in the valve body to locate the hole in the valve cone (172). This will prevent rotation while tightening.
3. Install 'O' ring (190) on three screw cover (189).
4. Install spring (191) and locate cover over spring. Secure cover with three capscrews (184). Use Loctite® 243 on threads.
5. Install diaphragm (173) in body and over valve cone (172). Diaphragm edge must be seated in valve body recess.
6. Install 'O' ring (177) on four screw cover (175). Install cover and ensure that fitting port is on the same side as port in valve body. Apply Loctite® 243 to the capscrew threads (184) and secure cover (175).
7. Install spring (181) and ball (178) in body (195). Screw emergency stop button into body.
8. Install 'O' rings (177 and 182) and protector (180) on valve (179). Install valve assembly on body.
9. Install 'O' rings (177) on shuttle valve stop (176). Install ball (178) and shuttle valve assembly in body.

Drum Guard Installation (optional feature)

Refer to Dwg. MHP0492.

To install a wire rope guard or reverse the position of the guard use the following procedures:

1. Remove nuts (27) and washers (28) from spacers (29) on the end opposite the motor.
2. Pry end cover (15) from the winch.
3. Install one 'O' ring (157) on each spacer (29) followed by wire rope guard (156).
4. Install remaining 'O' rings (157) on spacers (29). Position 'O' rings approximately one inch (25 mm) into the bore at each end of the wire rope guard locating tubes. 'O' rings act to prevent drum guard vibration during winch operation.
5. Reinstall end cover assembly being careful to align free wheel clutch (23) with drum (32) and output shaft (35) gear teeth. Rotate drum slowly to assist engagement. Tap cover into position.
6. Install lockwashers (28) and nuts (27) on spacers (29).

Testing

Operational Tests

Prior to initial use, all new, altered or repaired winches shall be tested to ensure proper operation.

1. Operate winch in both directions with no load.
2. Check operation of free wheel clutch and brake.
3. Check operation of limit switches and other safety devices when provided.
4. Check all winch mounting fasteners are secure.

Load Test

Prior to initial use, all new, extensively repaired, or altered winches shall be load tested by or under the direction of a person trained in safety and operation of this winch, and a written report furnished confirming the rating of the winch. Test loads shall not be less than 100% of rated line pull and should not exceed 125% of the rated line pull. Testing to more than 125% of rated capacity may be required to comply with standards outside of the USA.

WINCH ASSEMBLY PARTS DRAWING

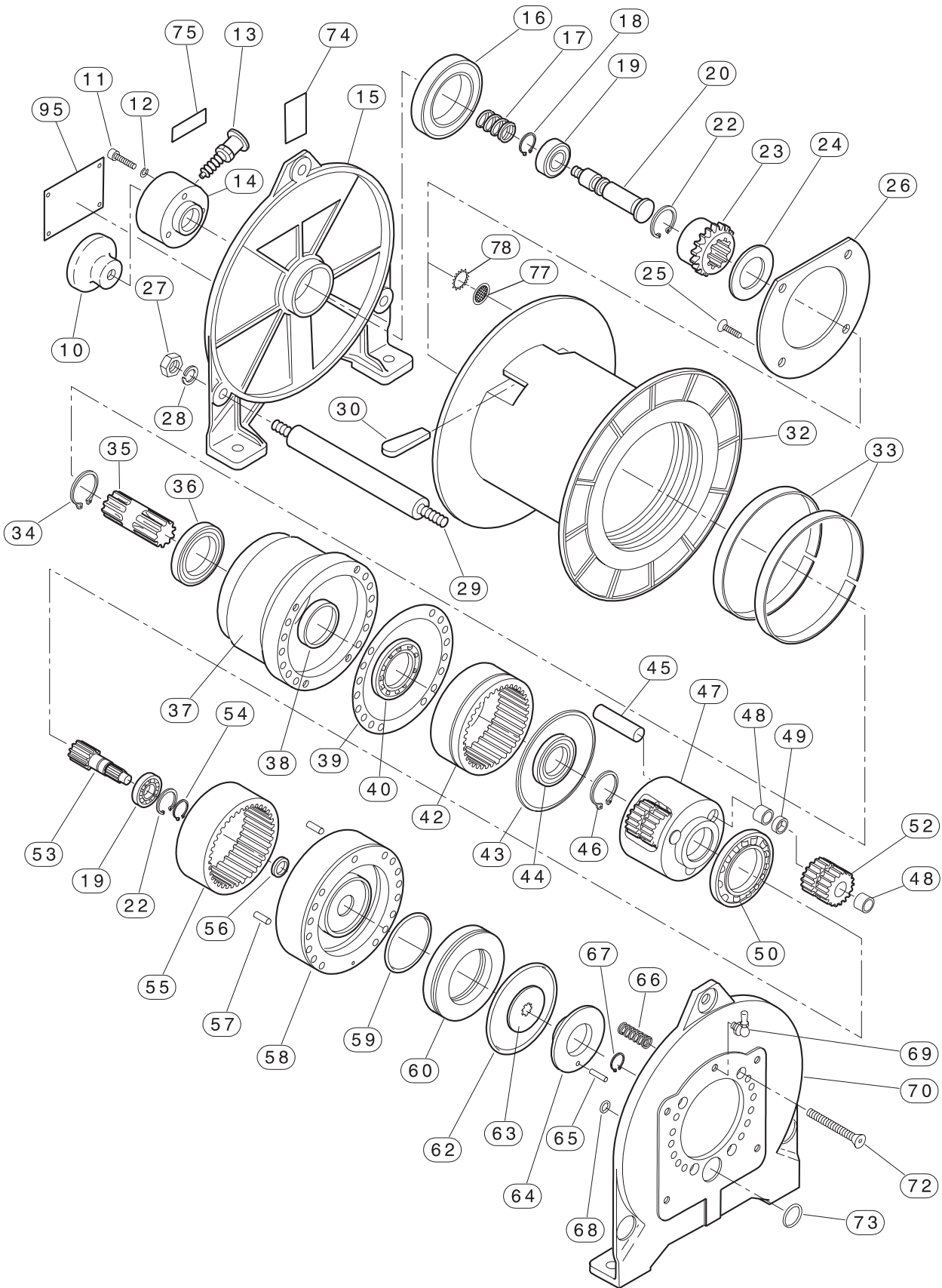

(Dwg. MHP0451)

WINCH ASSEMBLY PARTS LIST

ITEM NO.	DESCRIPTION OF PART	QTY TOTAL	PART NUMBER
15	Rear End Cover	1	96180001
16	Bearing	1	50050010
19	Bearing	1	50000002
22	Retainer Ring	1	47703032
24	Spacer	1	96180024
25	Screw	4	41101203
26	Disc	1	96180064
27	Nut	6	43000211
28	Lockwasher	6	45200010
29	Spacer (short drum)	3	96180004
	Spacer (long drum)		96180069
30	Wire Rope Anchor	1	96180006
32	Drum (6-1/8 in. long)	1	96180055
	Drum (12-1/4 in. long)		96180068
33	Wear Ring	2	96180058
34	Retainer Ring	1	47700029
35	Output Shaft	1	96180061
36	Bearing	1	50050006
37	Gear Housing	1	96180005
• 38	Oil Seal	1	58017530
• 39	Gasket	1	96180042
40	Bearing	1	50800006
42	Ring Gear	1	96180008
• 43	'O' Ring	1	58212629
44	Bearing	1	50800005
45	Pin	3	96090039
46	Retainer Ring	1	47802139
47	Planetary Hub	1	96180041
48	Bearing	6	56501713

ITEM NO.	DESCRIPTION OF PART	QTY TOTAL	PART NUMBER
49	Spacer	3	96090026
50	Bearing	1	50800009
52	Planetary Gear	3	96180009
53	Sun Gear	1	96180011
54	Retainer Ring	1	47700015
55	Ring Gear	1	96090038
• 56	Oil Seal	1	58019830
57	Pin	2	46001116
58	Drum Shaft	1	96180057
• 59	'O' Ring	1	58232229
60	Brake Piston	1	96090113
• 62	'O' Ring	1	58232329
• 63	Brake Disc	1	96090049
64	Plate	1	96180012
65	Pin	1	46406118
66	Spring	4	69165532
67	Retainer Ring	1	47700012
• 68	'O' Ring	1	58212529
69	Grease Fitting	1	67102227
70	Front End Cover	1	96180002
72	Screw	4	41103903
• 73	'O' Ring	1	58218129
74	Warning Label	1	71060529
75	Wire Rope Winding Label	1	96180087
76	Liftstar Label	1	96180079
77	Vent Screen	1	
78	Retainer	1	
95	Nameplate	1	66709741

Winches with Free Spool Clutch

Substitute or add the following parts on winches with free spool clutch

10	Handle	1	69566232
11	Capscrew	3	41307906
12	Lockwasher	3	45200005
13	Plunger	1	66288132
14	Plunger Body	1	96180060
15	Rear End Cover	1	96180063
17	Spring	1	69188932
18	Retainer Ring	1	47700014

19	Bearing	1	50000002
20	Axle (short drum)	1	96180059
	Axle (long drum)		96180072
22	Retainer Ring	1	47703032
23	Clutch	1	96180062
32	Drum (6-1/8 in. long)	1	96180056
	Drum (12-1/4 in. long)		96180071

• Recommended Spare

MOTOR ASSEMBLY PARTS DRAWING

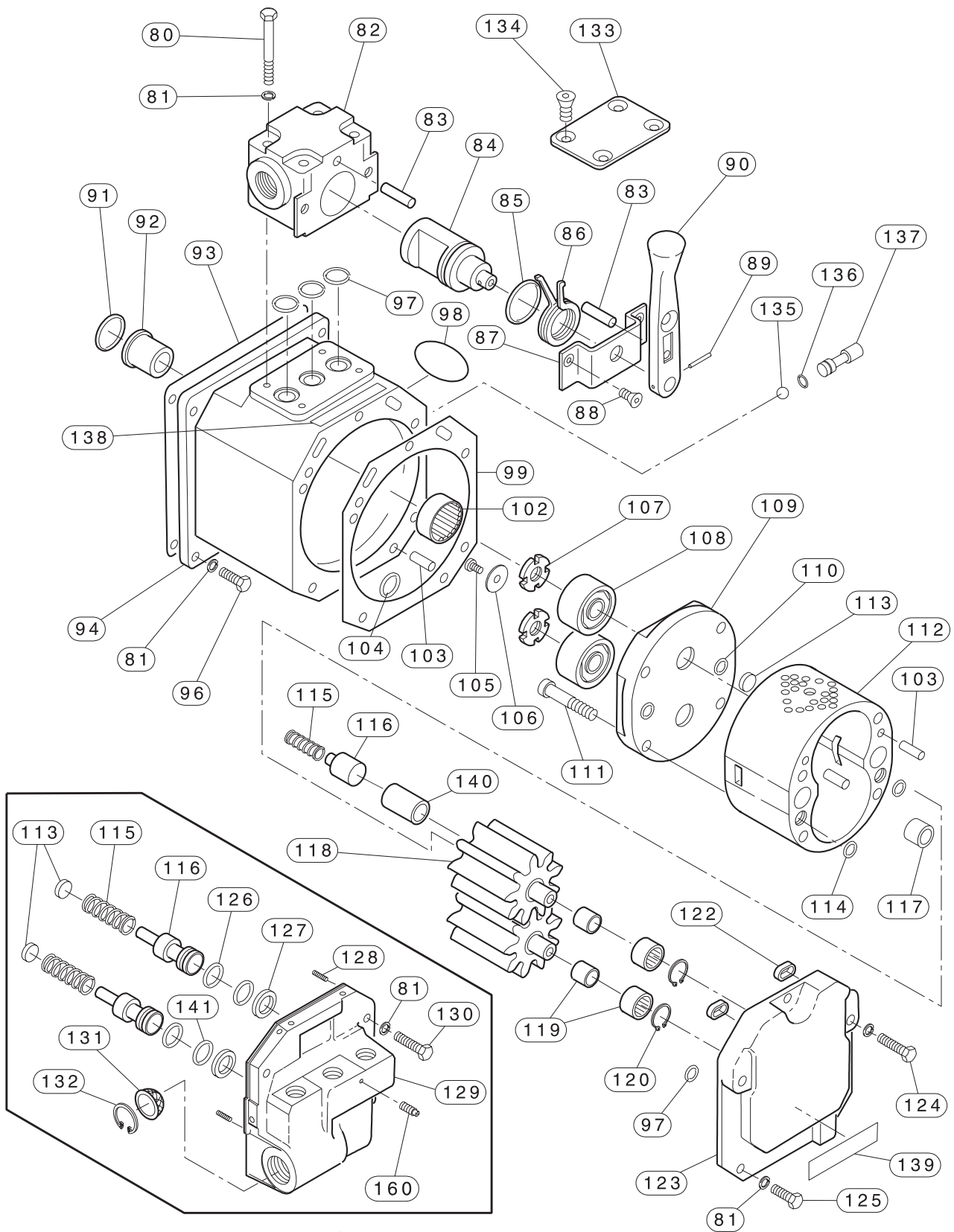

Remote Control

MOTOR ASSEMBLY PARTS LIST

ITEM NO.	DESCRIPTION OF PART	QTY TOTAL	PART NUMBER
80	Capscrew	4	41016601
81	Lockwasher	17	45200006
82	Valve Housing	1	96180032
83	Pin	2	46001216
84	Rotary Valve	1	96180033
• 85	'O' Ring	1	58217629
86	Spring	1	96180035
87	Bracket Stop	1	96180034
88	Screw	2	41103403
89	Pin	1	46507220
90	Handle	1	96180031
• 91	'O' Ring	1	58218229
92	Coupling	1	96180014
• 93	Gasket	1	96180065
94	Motor Housing	1	96180015
96	Capscrew	4	41000201
• 97	'O' Ring	5	58220929
98	Liftstar Decal	1	38544235
	Pullstar Decal		71327126
• 99	Gasket	1	96180066
102	Bearing	1	56323225
103	Pin	6	46000416
• 104	'O' Ring	2	58224929
105	Capscrew	1	41306706
106	Washer	1	96090032

ITEM NO.	DESCRIPTION OF PART	QTY TOTAL	PART NUMBER
107	Nut	2	57000002
108	Bearing	2	50600002
109	Motor Front Plate	1	96090008
• 110	'O' Ring	2	58222329
111	Capscrew	4	41300806
112	Motor Housing	1	96090007
113	Slide Valve	1	94120030
• 114	'O' Ring	2	58205029
115	Spring	1	69143932
116	Stopper Spool	1	96180038
117	Washer	1	96180037
118	Gear Set	1 Set	*
119	Bearing	2	56461912
120	Retainer Ring	2	47801339
• 122	Seal	2	96180030
123	Motor Cover	1	96180029
124	Capscrew	2	41007501
125	Capscrew	3	41000101
135	Ball	1	69401625
• 136	'O' Ring	1	58212229
137	Shuttle Valve Stop	1	96090223
138	Control Direction Label	1	96180083
139	Ingersoll-Rand Label	1	71106322
140	Spacer	1	96180039
160	Setscrew	1	42007707

* Available as a set consisting of one each of parts 96090031 and 96090030

Remote Control Assembly

Substitute or add the following parts on winches with Remote Pilot Pendant Control.

113	Slide Valve	2	94120030
115	Spring	2	94240224
116	Stopper Spool	2	94240212
• 126	Quad Ring	2	58228929
• 127	Seal Washer	2	96090042
128	Screw	2	42007407
129	Motor Cover	1	96090070

130	Capscrew	4	41312206
• 131	Filter Screen	1	61909028
132	Retainer Ring	1	47703018
133	Cover	1	96180036
134	Screw	4	41103603
• 141	Quad Ring	2	58231229

• Recommended Spare

MOTOR WITH EMERGENCY STOP ASSEMBLY PARTS DRAWING

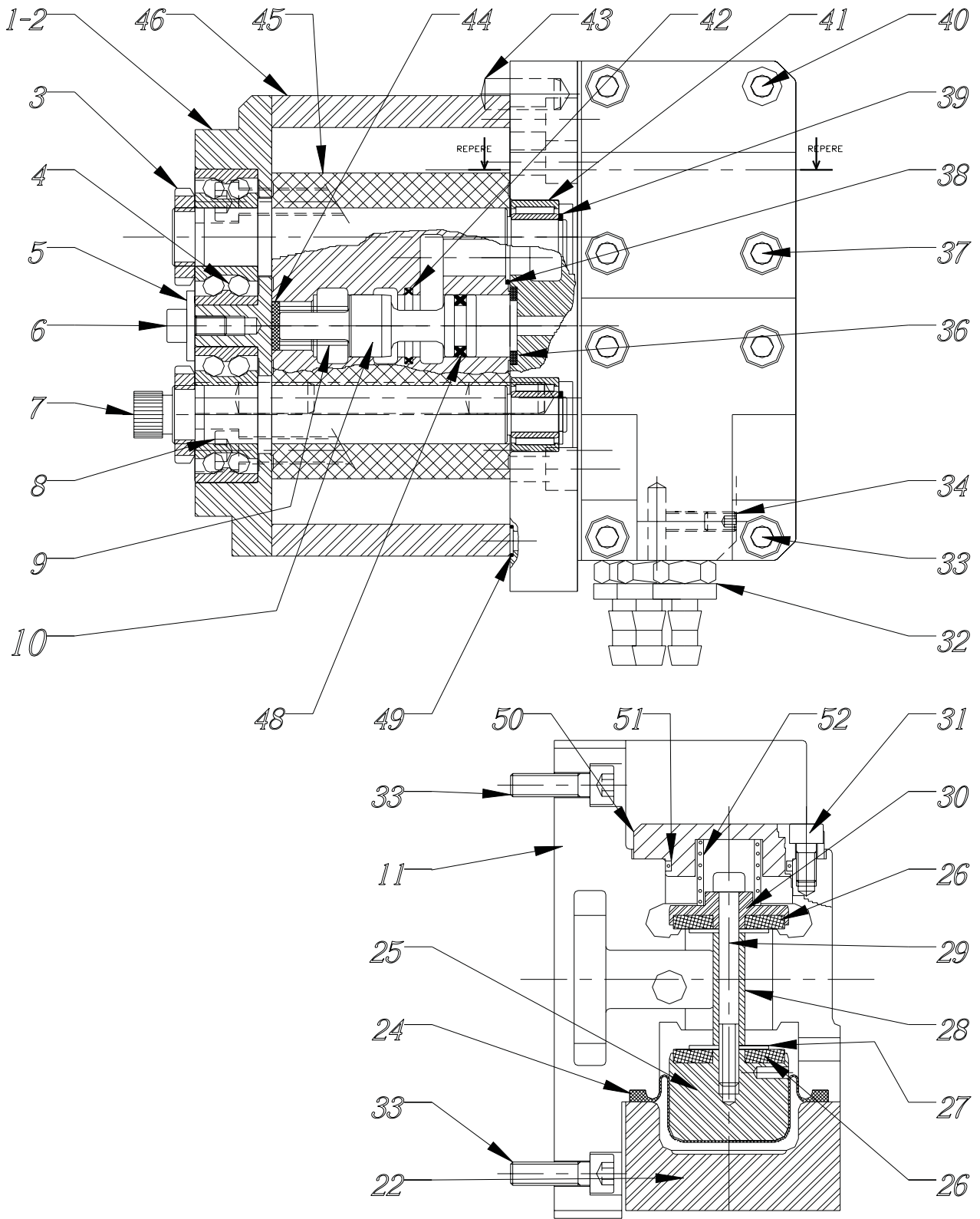

(Dwg. MHP1590)

MOTOR WITH EMERGENCY STOP ASSEMBLY PARTS LIST

ITEM NO.	DESCRIPTION OF PART	QTY TOTAL	PART NUMBER
1	Motor Flange	1	96090008
• 2	'O' Ring	3	58222329
3	Locknut	2	57000002
4	Bearing	2	50600002
5	Washer	1	96090032
6	Screw	1	41306706
7	Drive Gear	1	96090031
8	Screw	4	41300806
9	Spring	2	94240224
10	Slide Valve	2	94240212
11	Motor Cover	1	96090270
22	Cover	1	96090271
• 24	Diaphragm	1	67716341
25	Valve	1	96170054
• 26	Seal Washer	2	96170056
27	Washer	2	45700005
28	Spacer	2	96170055
29	Screw	1	41308206
30	Valve	1	96170053
31	Screw	3	41326306

ITEM NO.	DESCRIPTION OF PART	QTY TOTAL	PART NUMBER
32	Fitting	5	61652632
33	Screw	6	41322206
34	Screw	1	42008307
36	Stop	2	96090042
37	Screw	4	41322306
• 38	'O' Ring	2	58205029
39	Retainer Ring	2	47801339
40	Screw	2	41324306
41	Needle Bearing	2	56461912
• 42	Quad Ring	2	58231229
43	Pin	6	46000416
44	Slide Valve	2	94120030
45	Idle Gear	1	96090030
46	Motor Housing	1	96090007
• 48	Quad Ring	2	58228929
• 49	'O' Ring	2	58212229
50	Cover	1	96170059
• 51	'O' Ring	1	58214829
52	Spring	1	69158732
55	Motor with emergency stop valve assembly (incl's items 1 through 52)	1	76090430

• Recommended Spare

REMOTE CONTROL PARTS ASSEMBLY DRAWINGS

With Emergency Stop

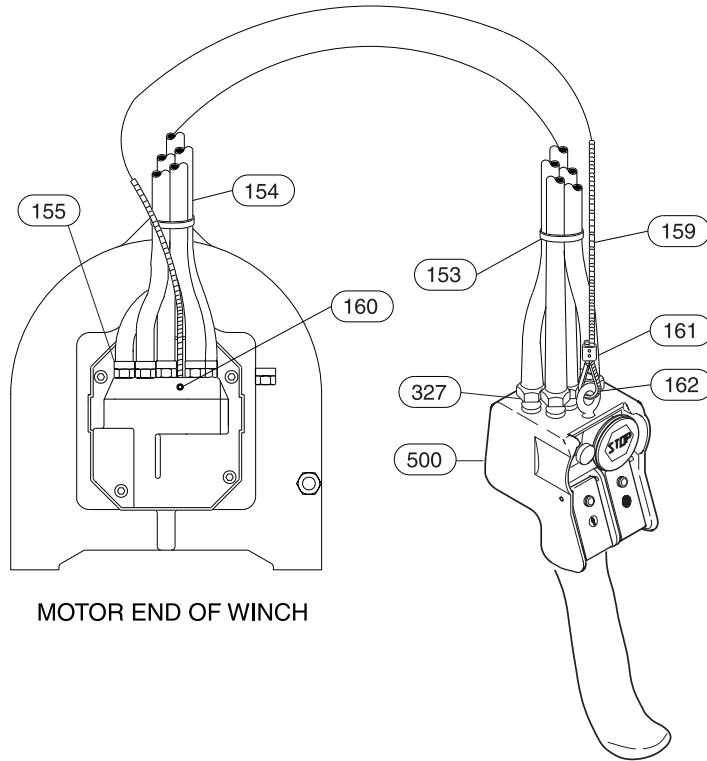

(Dwg. MHP1593)

Without Emergency Stop

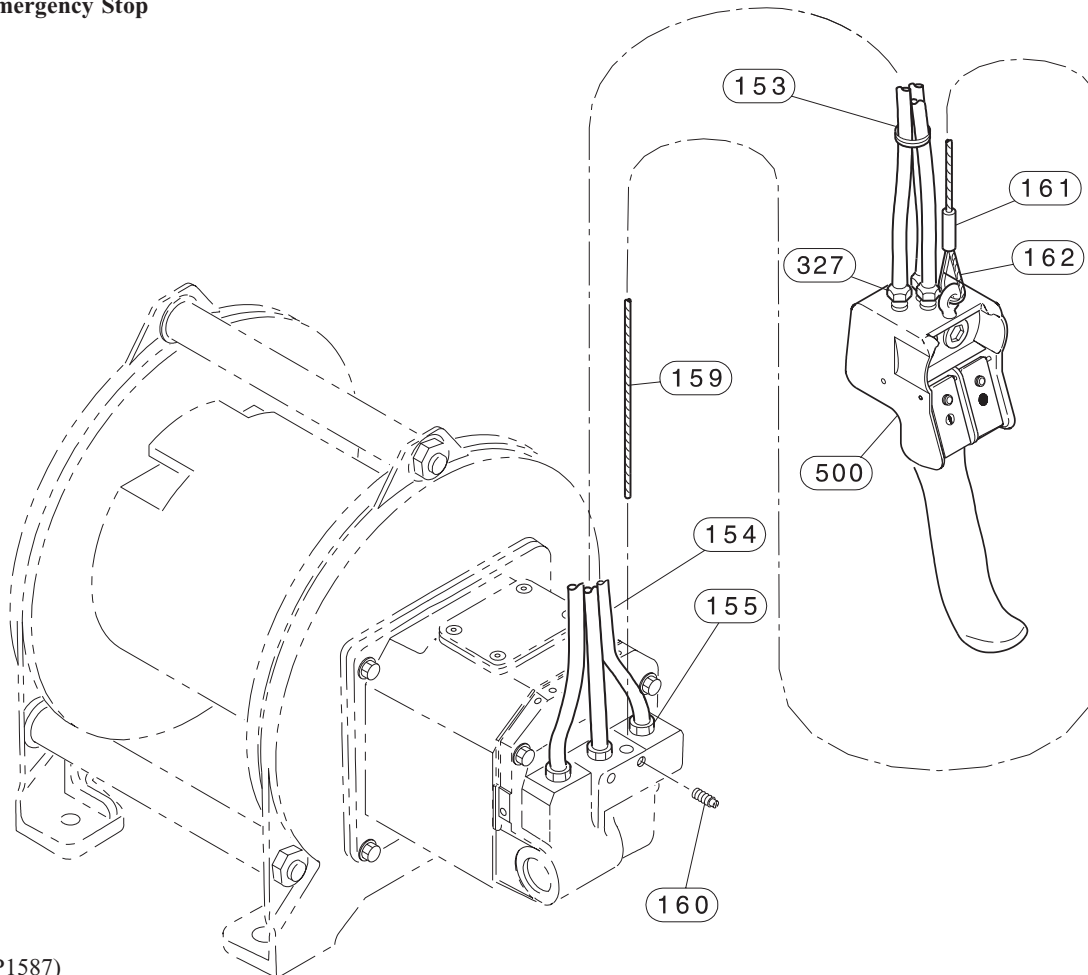

(Dwg. MHP1587)

REMOTE CONTROL PARTS LIST

ITEM NO.	DESCRIPTION OF PART	QTY TOTAL	PART NUMBER	
			With E-Stop	Without E-Stop
500	Pendant Assembly (incl's item 327)	1	PHS2E-U	PHS2E
327	Fitting, Adapter	3(5)	52092	
152	Fitting, Internal Hose Connector*	3(5)	51029	
153	Hose Tie	1	54235	
154	Hose (specify length when ordering)	3(5)	50923	
155	Fitting, Barbed	3(5)	61652632	
159	Strain Relief Wire (specify length when ordering)	1	71073506	
160	Setscrew	1	42007707	
161	Sleeve Clamp	1	61125032	54799
162	Thimble	1	69325332	71111827
---	Exhaust Valve Kit (required for hose lengths greater than 20 ft (6 m))	As req'd**	20417	

- () Quantity required for Remote Control with Emergency Stop
- * Not Illustrated.
- ** 0 - 19 ft (0 - 6 m) Hose Length, 0 Exhaust Valve Kits Required.
 20 - 39 ft (6 - 12 m) Hose Length, 2 Exhaust Valve Kits Required.
 40 - 59 ft (12 - 18 m) Hose Length, 4 Exhaust Valve Kits Required.

EMERGENCY STOP VALVE ASSEMBLY PARTS DRAWINGS

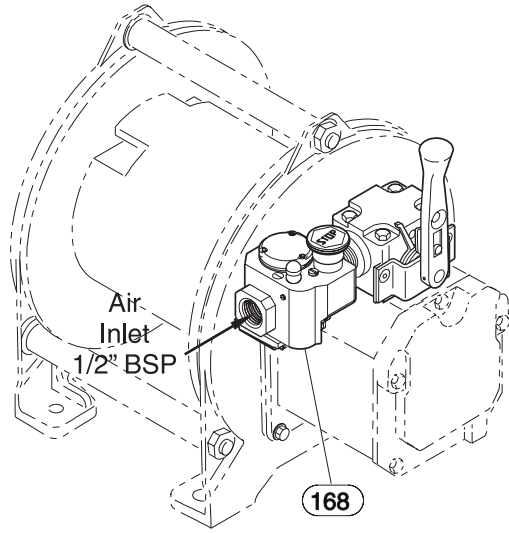

(Dwg. MHP1588)

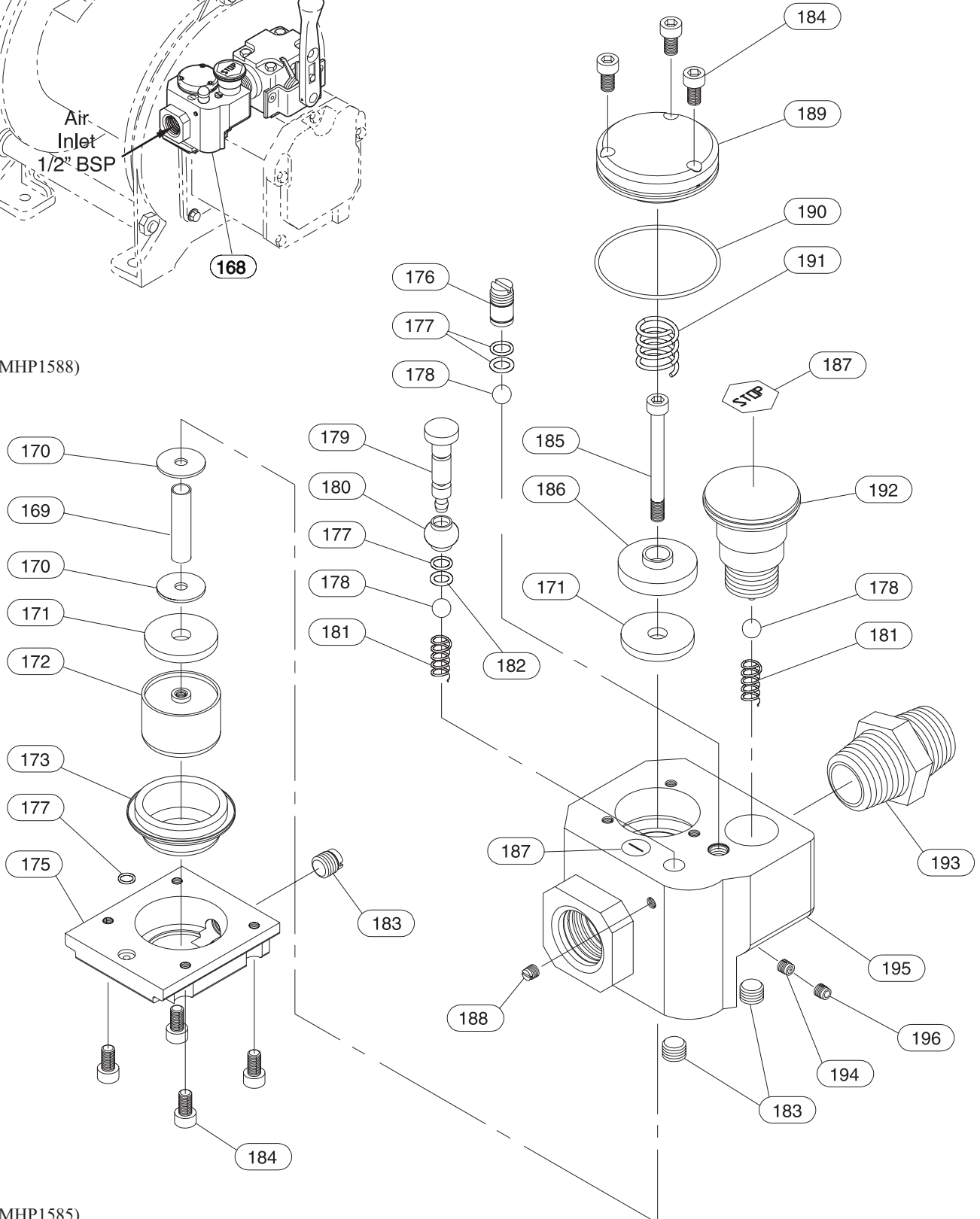

(Dwg. MHP1585)

EMERGENCY STOP VALVE PARTS LIST

ITEM NO.	DESCRIPTION OF PART	QTY TOTAL	PART NO.
168	Emergency Stop Valve Assembly (incl's items 169 through 196)	1	
169	Spacer Tube	1	96170055
170	Washer	2	45700005
• 171	Seal Washer	2	96170056
172	Valve Cone	1	96170054
• 173	Diaphragm	1	67716341
175	Cover	1	96170052
176	Shuttle Valve Stop	1	95790106
• 177	'O' Ring	4	58209229
178	Ball	3	69401625
179	Spool	1	95790104
180	Protector	1	95790107
181	Spring	2	69128541
• 182	'O' Ring	1	58235329
183	Plug	3	65107741
184	Screw	7	41326306
185	Screw	1	41308206
186	Valve Cone	1	96170053
187	Label Kit	1	95790111
188	Screw	1	42008307
189	Cover	1	96170059
• 190	'O' Ring	1	58214829
191	Spring	1	69158732
192	Emergency Stop Button	1	95790108
193	Fitting	1	61330732
194	Nozzle	1	96170071
195	Body	1	96170098
196	Screw	1	42007807

• Recommended Spare

TWO LEVER PENDANT ASSEMBLY PARTS DRAWINGS

Pendant without Emergency Stop

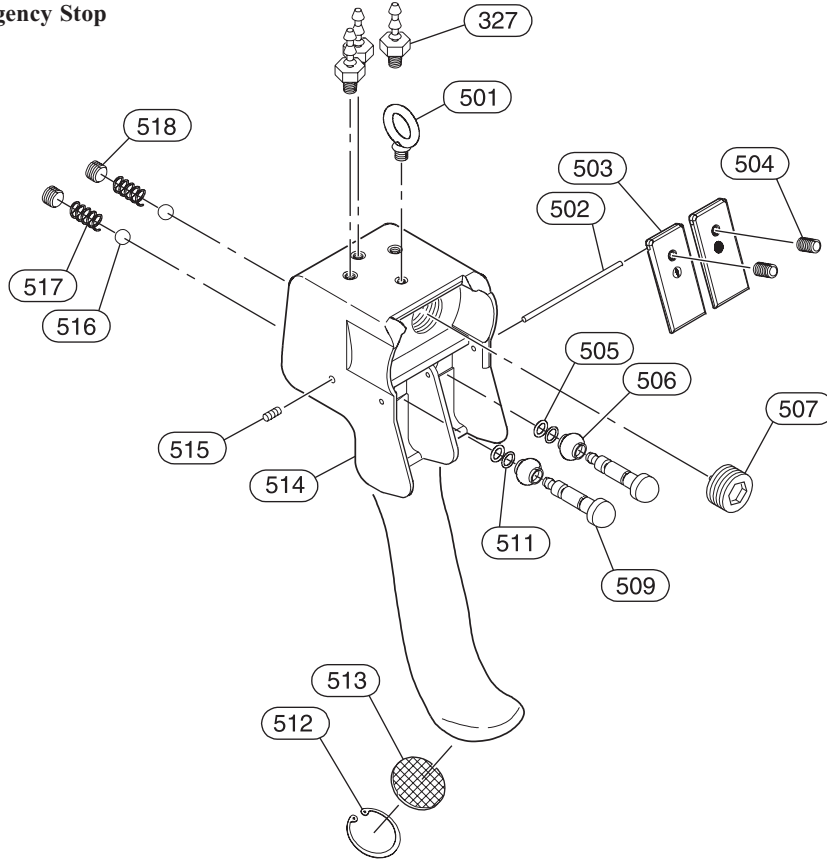

(Dwg. MHP1558)

Pendant with Emergency Stop

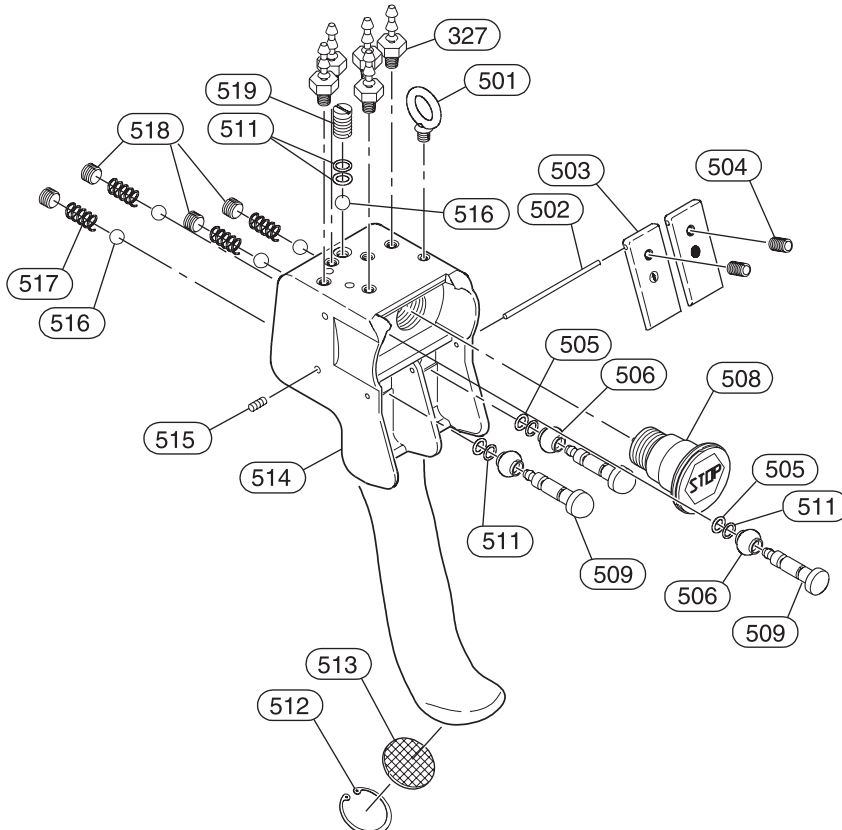

(Dwg. MHP1544)

TWO LEVER PENDANT ASSEMBLY PARTS LIST

ITEM NO.	DESCRIPTION OF PART	QTY TOTAL	PART NO.	
			Without E-Stop	With E-Stop
500	Pendant Assembly	1	PHS2E	PHS2E-U
327	Fitting	3(5)	61652632	
501	Lifting Eye	1	64222332	
502	Pin	1	95790040	
503	Lever	2	95790122	
504	Screw	2	42006207	
• 505	'O' Ring	2(3)	58235329	
506	Protector	2(3)	95790107	
507	Plug	1	65129541	---
508	Emergency Stop Valve	1	---	95790108
509	Valve	2(3)	95790104	
• 511	'O' Ring	2(5)	58209229	
512	Retainer Ring	1	47713030	
513	Exhaust Washer	1	67600303	
514	Pendant Handle	1	95790129	995790116
515	Screw	2(3)	42008307	
• 516	Ball	2(5)	69401625	
517	Spring	2(4)	69128541	
518	Plug	2(4)	65107741	
519	Plug	1	---	95790108
521	Label Kit	1	---	95790111
	Label: "Read the Manual"	1	96180098	
	Label: "Do Not Use for Lifting Personnel"	1	96180100	

() Quantity Required for Pendants with Emergency Stop

• Recommended Spare

DRUM GUARD ASSEMBLY DRAWING AND PARTS LIST

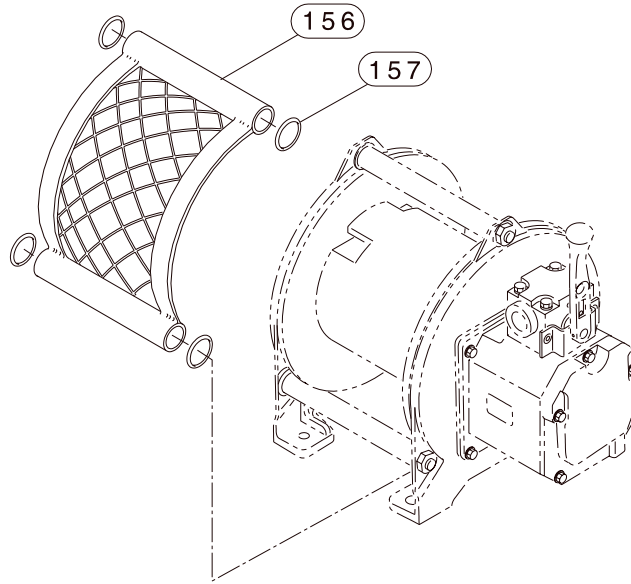

(Dwg. MHP0492)

ITEM NO.	DESCRIPTION OF PART	QTY TOTAL	PART NUMBER
156	Drum Guard Assembly (includes item 157) short (6-1/8 in.) drum	1	76180057
	Drum Guard Assembly (includes item 157) long (12-1/4 in.) drum		76180059
157	'O' Ring	4	58211529

SLING MOUNT ASSEMBLY DRAWING AND PARTS LIST

Special Order Only

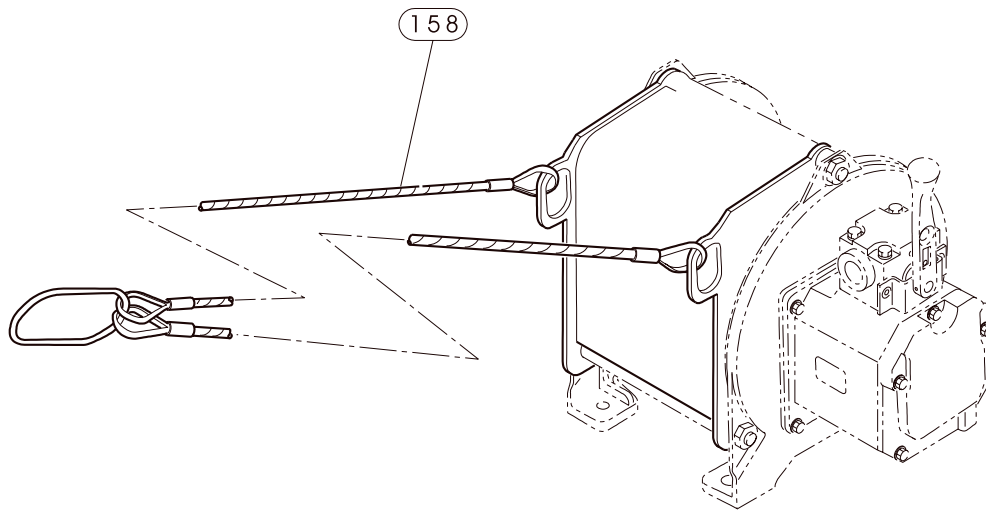

(Dwg. MHP0493)

To Be Used in Pulling Applications Only

ITEM NO.	DESCRIPTION OF PART	QTY TOTAL	PART NUMBER
158	Sling (short drum)	1	96180046
	Sling (long drum)		Not Available

KITS AND ACCESSORIES

DESCRIPTION	PART NUMBER
Lubricant	LUBRI-LINK-GREEN®
Touch-up Paint (yellow)	FAP-237Y
Filter (1/2 in.)	F18-C4-SK00
Lubricator (1/2 in.)	L18-C4-LK00
Regulator (1/2 in.)	R18-C4-F0G0
Pipeline Strainer	EU-A267
Liquidator (1/2 in.)	8844-B1-035
Remote Control Kit	LS613R-VCM plus Pendant Assembly Item 500

SERVICE NOTES

PARTS ORDERING INFORMATION

The Liftstar 600R and Pullstar 1000R winches are designed and constructed to provide long, trouble-free service. In time it may be necessary to order and install new parts to replace those that have been subjected to wear.

The use of other than **Ingersoll-Rand** Material Handling replacement parts may result in decreased winch performance, and may, at the company's option, invalidate the warranty. For prompt service and genuine **Ingersoll-Rand** Material Handling replacement parts, provide your nearest Distributor with the following:

1. Complete model number and serial number as it appears on the nameplate.
2. Part number(s) and part description as shown in this manual.
3. Quantity required.

For your convenience and future reference it is recommended that the following information be recorded.

Model Number _____

Serial Number _____

Date Purchased _____

NOTICE

- **Continuing improvement and advancement of design may cause changes to this equipment which are not included in this manual. Manuals are periodically revised to incorporate changes. Always check the manual edition number on the front cover for the latest issue.**
- **Sections of this manual may not apply to your winch.**
- **Using other than genuine Ingersoll-Rand Material Handling parts may void the warranty.**

Return Goods Policy

Ingersoll-Rand will not accept any returned goods for warranty or service unless prior arrangements have been made and written authorization has been provided from the location the goods were purchased.

Winches which have been modified without **Ingersoll-Rand** approval, mishandled or overloaded will not be repaired or replaced under warranty. A printed copy of the warranty which applies to this winch is provided inside the back cover of this manual.

Disposal

When the life of the unit has expired, it is recommended that it be disassembled, degreased and parts separated as to materials so that they may be recycled.

For additional information contact:

Ingersoll-Rand Material Handling

P.O. Box 24046
2724 Sixth Avenue South
Seattle, WA 98124-0046 USA
Phone: (206) 624-0466
Fax: (206) 624-6265
or

Ingersoll-Rand Material Handling

Douai Operations

111, Avenue Roger Salengro
59450 Sin Le Noble, France
Phone: (33) 03-27-93-08-08
Fax: (33) 03-27-93-08-00

LIMITED WARRANTY

Ingersoll-Rand Company (**I-R**) warrants to the original user its Hoists and Winches (Products) to be free of defects in material and workmanship for a period of one year from the date of purchase. **I-R** will repair, without cost, any Product found to be defective, including parts and labor charges, or at its option, will replace such Products or refund the purchase price less a reasonable allowance for depreciation, in exchange for the Product. Repairs or replacements are warranted for the remainder of the original warranty period.

If any Product proves defective within its original one year warranty period, it should be returned to any Authorized Hoist and Winch Service Distributor, transportation prepaid with proof of purchase or warranty card.

This warranty does not apply to Products which **I-R** has determined to have been misused or abused, improperly maintained by the user, or where the malfunction or defect can be attributed to the use of non-genuine **I-R** parts.

I-R makes no other warranty, and all implied warranties including any warranty of merchantability or fitness for a particular purpose are limited to the duration of the expressed warranty period as set forth above. I-R's maximum liability is limited to the purchase price of the Product and in no event shall I-R be liable for any consequential, indirect, incidental, or special damages of any nature rising from the sale or use of the Product, whether based on contract, tort, or otherwise.

Note: Some states do not allow limitations on incidental or consequential damages or how long an implied warranty lasts so that the above limitations may not apply to you.

This warranty gives you specific legal rights and you may also have other rights which may vary from state to state.

IMPORTANT NOTICE

It is our policy to promote safe delivery of all orders.

This shipment has been thoroughly checked, packed and inspected before leaving our plant and receipt for it in good condition has been received from the carrier. Any loss or damage which occurs to this shipment while en route is not due to any action or conduct of the manufacturer.

VISIBLE LOSS OR DAMAGE

If any of the goods called for on the bill of lading or express receipt are damaged or the quantity is short, do not accept them until the freight or express agent makes an appropriate notation on your freight bill or express receipt.

CONCEALED LOSS OR DAMAGE

When a shipment has been delivered to you in apparent good condition, but upon opening the crate or container, loss or damage has taken place while in transit, notify the carrier's agent immediately.

DAMAGE CLAIMS

You must file claims for damage with the carrier. It is the transportation company's responsibility to reimburse you for repair or replacement of goods damaged in shipment. Claims for loss or damage in shipment must not be deducted from the **Ingersoll-Rand** invoice, nor should payment of **Ingersoll-Rand** invoice be withheld awaiting adjustment of such claims as the carrier guarantees safe delivery.

You may return products damaged in shipment to us for repair, which services will be for your account and form your basis for claim against the carrier.

United States Office Locations

For Order Entry and Order Status

**Ingersoll-Rand
Distribution Center**
P.O. Box 618
510 Hester Drive
White House, TN 37188
Phone: (615) 672-0321
Fax: (615) 672-0801

For Technical Support

Ingersoll-Rand
P.O. Box 24046
2724 Sixth Ave South
Seattle, WA 98124-0046
Phone: (206) 624-0466
Fax: (206) 624-6265

Web Site:
www.ingersoll-rand.com

Regional Sales Offices

Chicago, IL
888 Industrial Drive
Elmhurst, IL 60126
Phone: (630) 530-3800
Fax: (630) 530-3891

Detroit, MI
23192 Commerce Drive
Farmington Hills, MI 48335
Phone: (248) 476-6677
Fax: (248) 476-6670

Houston, TX
450 Gears Road
Suite 210
Houston, TX 77067-4516
Phone: (281) 872-6800
Fax: (281) 872-6807

Los Angeles, CA
11909 E. Telegraph Road
Santa Fe Springs,
CA 90670-0525
Phone: (562) 948-4189
Fax: (562) 948-1828

Philadelphia, PA
P.O. Box 425
900 E. 8th Ave., Suite 103
King of Prussia, PA 19406
Phone: (610) 337-5930
Fax: (610) 337-5912

International Office Locations

Offices and distributors in principal cities throughout the world. Contact the nearest **Ingersoll-Rand** office for the name and address of the distributor in your country or write/fax to:

Ingersoll-Rand
P.O. Box 24046
2724 Sixth Ave South
Seattle, WA 98124-0046
USA
Phone: (206) 624-0466
Fax: (206) 624-6265

Canada
National Sales Office
Regional Warehouse
Toronto, Ontario
51 Worcester Road
Rexdale, Ontario
M9W 4K2
Phone: (416) 213-4500
Fax: (416) 213-4510
Order Desk
Fax: (416) 213-4506

Regional Sales Offices

Edmonton, Alberta
1430 Weber Center
5555 Calgary Trail N.W.
Edmonton, Alberta
T6H 5G8
Phone: (403) 438-5039
Fax: (403) 437-3145

Montreal, Quebec
3501 St. Charles Blvd.
Kirkland, Quebec
H9H 4S3
Phone: (514) 695-9040
Fax: (514) 695-0963

British Columbia
1200 Cliveden Avenue
Delta, BC.
V3M 6G4
Phone: (604) 523-0803
Fax: (604) 523-0801

Latin America Operations
Ingersoll-Rand
Production Equipment
Group
730 N.W. 107 Avenue, Suite
300 Miami, FL 33172-3107
USA
Phone: (305) 559-0500
Fax: (305) 222-0864

Europe, Middle East and Africa
Ingersoll-Rand Company
111, avenue Roger Salengro
59450 Sin Le Noble, France
Phone: (33) 3-27-93-08-08
Fax: (33) 3-27-93-08-00

Asia Pacific Operations
Ingersoll-Rand (Japan) Ltd.
Shin-Yokohama Square Bldg.
(5th Floor)
2-3-12 Shin-Yokohama,
Kouhoku-Ku,
Yokohama-shi, Kanagawa
Pref. 222 Japan
Phone: 81-45-476-7800
Fax: 81-45-476-7806

Russia
Ingersoll-Rand Company
Kuznetsky Most, 21/5
Moscow, 103895
Russia.
Phone: 7-501-921-53-21
7-501-923-91-34
Fax: 7-501-924-46-25